

## SteamChef™ 6

Boilerless Convection Steamer,  
Automatic Water Fill & Drain,  
13.5 kW Boiler-Free Counter Type Design



MODEL:  22CET6.1



### Cleveland Standard Features

- Cooking capacity for up to six 12" x 20" x 2.5" deep steam table pans (1/1 G/N, 65 mm).
- High-speed electric convection steamer with open style 1.5 gallon water reservoir located at the bottom of the cooking compartment for easy access and maintenance.
- Fan forced convection steam with patented **KleanShield™** cooking compartment design. **KleanShield™** collects and removes condensate waste from the cooking compartment. This keeps the compartment clean, safe from impurities and easy to maintain. Eliminates foaming and avoids contamination of the reservoir water.
- Automatic water level controls, fills when main power switch is turned ON, Low Water and High Water probes inside cooking compartment maintains water levels during cooking, eliminating the need to manually refill and monitor water level during cooking. Additional Safety Overflow Standpipe. 193° preheat and standby temperature. High Temperature Safety Shut-off.
- Steam and Fan Shut Off Control when compartment door is opened.
- 13.5 kW electric heating elements are in aluminum blocks for fast and ultra efficient heat transfer. Elements never need deliming because they are not immersed in water.
- Exclusive **SureCook** Compartment Controls improves cooking speed and accuracy. New energy saving design reduces water and electric usage. On-demand power control for faster heat up and recovery. Energy saving Standby Feature when not in use. The **SureCook** timer automatically adjusts the cooking time with the volume of product being cooked, eliminating guesswork on when the product is finished. Includes a 60-Minute Electro-Mechanical Timer, LED Indicator Lights for **SureCook** Cycle, Power On and Reset. Timed and Manual Bypass Switch for constant steaming.
- Exclusive **SteamChef™** Automatic Drain Control. Generator Drains when main power is turned OFF via 1/2" ball valve with micro switch circuitry. Simple 1 1/4" NPT drain connection required with water saving cold water condenser and 3 minute rinse feature.
- Left Hand Door Hinging: Compartment Doors hinged on the left, controls on the right.
- Exclusive, durable 14 gauge stainless steel compartment door and latch withstands abuse and heavy wear. Two piece compartment door with free floating inner door is self adjustable and prevents leaks. Reversible door gasket doubles the life of the gasket.
- Heavy-duty 4" (102mm) Skid Resistant Adjustable Legs with Flanged Feet.
- Meets agency codes: specifically UL and cUL listed, classified to NSF#4 and Energy Star.



### Short Form Specifications

Shall be a Cleveland **SteamChef™ 6**, model 22CET6.1, one compartment high-speed electric convection steamer. \_\_\_\_ volt, \_\_\_\_ phase. Standard with **SureCook** Compartment Controls, 60-minute electro-mechanical timer with load compensating feature. Capacity for six 2.5" (1/1 G/N, 65 mm) full size steam table pans. 13.5 kW electric heating elements in aluminum blocks. Includes 1/2" ball valve style automatic drain. Automatic water level controls. Heavy-duty 14 gauge stainless steel cooking compartment door and latch. **KleanShield™** clean cavity protection. 4" Adjustable Legs

### Cleveland Standard Features

- Cooking capacity for up to six 12" x 20" x 2.5" deep steam table pans (1/1 G/N, 65 mm).
- High-speed electric convection steamer with open style 1.5 gallon water reservoir located at the bottom of the cooking compartment for easy access and maintenance.
- Fan forced convection steam with patented **KleanShield™** cooking compartment design. **KleanShield™** collects and removes condensate waste from the cooking compartment. This keeps the compartment clean, safe from impurities and easy to maintain. Reduces foaming and avoids contamination of the reservoir water.
- Automatic water level controls, fills when main power switch is turned ON, Low Water and High Water probes inside cooking compartment maintains water levels during cooking, eliminating the

SECT. B PAGE 3  
0707

- Each compartment has capacity for: Six, 12" x 20" x 2 1/2" deep Cafeteria Pans.
- Each compartment has capacity for: Twelve, 12" x 20" x 1" deep Cafeteria Pans.
- Each compartment has capacity for: Four, 12" x 20" x 4" deep Cafeteria Pans.

## COLD WATER

C-1: Feed water for reservoir, 35 Psi Minimum, 60 Psi Maximum.

C-2: Drain condenser water, 35 Psi Minimum, 60 Psi Maximum.

Two 3/4" NH-F (Garden Thread) connections. Use NSF approved hose.

## DRAIN CONNECTION

1 1/4" NPT-M

Do not connect other units to this drain.

Drain line must be vented. Vented drain connection included.

Do not connect drain to PVC pipe.

## OPERATING CLEARANCES

3" Left, 3" Right and 4" Rear.

## SERVICE CLEARANCES

12" on control side. Contact factory for variances to clearances.

## CONTROLS

SureCook 60-minute electro mechanical timer with load compensating feature.

Three function control switch for Timed Cooking and Continuous Steaming.

## APPROVALS

UL and cUL listed, classified to NSF#4 and Energy Star

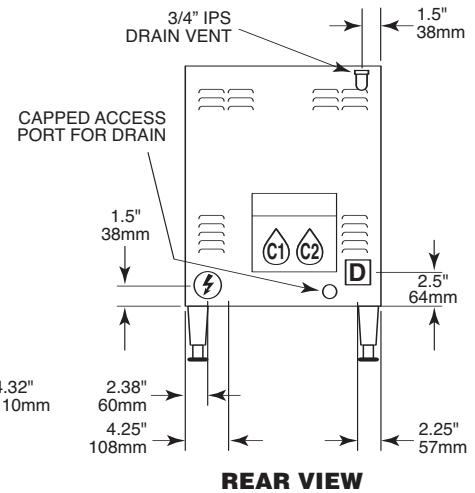
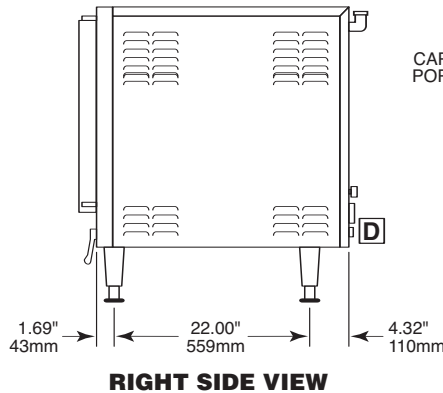
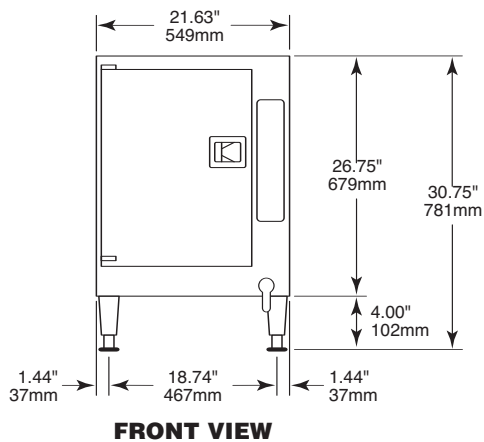
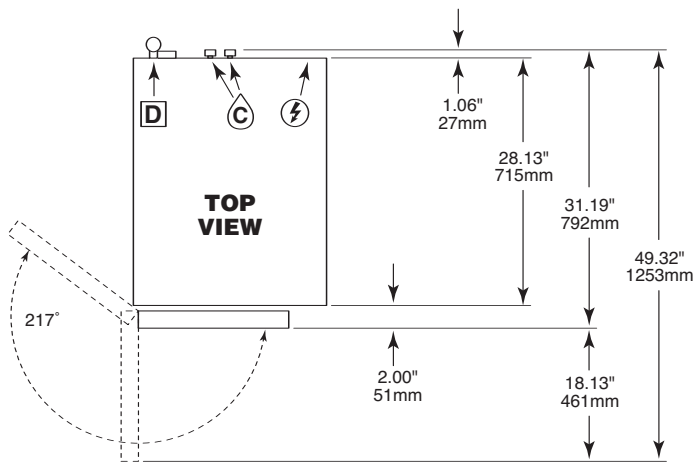

## ELECTRICAL ⚡

WATTS	VOLTS	PHASE	WIRES	CYCLE HERTZ	AMPS	SUPPLY CONNECTION WIRE SIZE (COPPER)*
-------	-------	-------	-------	-------------	------	---------------------------------------

### Standard Wattage

Three Phase - 13.5 kW Standard

13500	208	3	3	60	37.5	6
11300	220	3	3	60	29.7	8
13500	240	3	3	60	32.5	8
11300	440	3	3	60	14.9	12
13500	480	3	3	60	16.2	10

### Optional Low Wattage

Three Phase - 9 kW option

9400	208	3	3	60	26.1	8
5440	220	3	3	60	20.9	10
9400	240	3	3	60	22.6	10
5440	440	3	3	60	10.4	14
9400	480	3	3	60	11.4	14

\* For supply connection use only copper wire suitable for at least 75°C. (167°F).

WATTS	VOLTS	PHASE	WIRES	CYCLE HERTZ	AMPS	SUPPLY CONNECTION WIRE SIZE (COPPER)*
-------	-------	-------	-------	-------------	------	---------------------------------------

### Standard Wattage

Single Phase - 13.5 kW Standard

13500	208	1	2	60	64.9	4
11300	220	1	2	60	51.4	6
13500	240	1	2	60	56.3	4
11300	440	1	2	60	25.8	8
13500	480	1	2	60	28.1	8

### Optional Low Wattage

Single Phase - 9 kW option

9400	208	1	2	60	45.2	6
5440	220	1	2	60	36.1	8
9400	240	1	2	60	39.2	8
5440	440	1	2	60	18.0	10
9400	480	1	2	60	19.6	10

## NOTES:

Cleveland Range reserves right of design improvement or modification, as warranted.

Many regional, state and local codes exist and it is the responsibility of the owner and installer to comply with the codes.

Cleveland Range equipment is built to comply with applicable standards for manufacturers. Included among those approval agencies are U.L./NSF#4 and CSA (AGA, CGA).

(NOT TO SCALE)

SECT. B PAGE 4

0707

Litho in U.S.A.