



# 36 E Series Heavy Duty Range Attachment

Item: \_\_\_\_\_  
 Quantity: \_\_\_\_\_  
 Project: \_\_\_\_\_  
 Approval: \_\_\_\_\_  
 Date: \_\_\_\_\_

36 E Series Heavy Duty Range Attachment

Models:

36ES15

36ET15

Range Attachment With  
2 Boil Section Top



Model 36ES15

### Standard Features:

- Stainless steel front with black powder coat epoxy sides
- Stainless steel front rail
- 18" (457mm) boiling plate controlled by two (2), three-heat switches.
- Storage base with stainless steel door
- 6" (152mm) adjustable chrome plated legs (NSF)
- One Year limited parts & labor (USA & Canada)
- Available in single phase wiring only

### Optional Features:

- Stainless steel sides
- Stainless steel main back (S models)
- Swivel casters complete with front brakes (4)
- 6" (152mm) adjustable stainless steel legs.
- High voltage 460V
- Marine equipment - hand rails, drip tray stop and deck fasteners

NOTE: Attachments supplied with casters must be installed with an approved restraining device.

### Specifications:

Heavy-duty electric range attachment Model 36ES15 with boiling plate top and cabinet base. 18" (457mm) x 24" (610mm) top consists of two heat zones, each controlled by three heat switch, single phase only. Stainless steel front and black powder coat epoxy sides. Attachments are available with casters or for dais mount. Also available in modular top version, Model 36ET15.



Garland Commercial Industries, LLC  
 185 East South Street  
 Freeland, PA 18224  
 Phone: (570) 636-1000  
 Fax: (570) 636-3903

Garland Commercial Ranges Ltd  
 1177 Kamato Road,  
 Mississauga, Ontario  
 L4W 1X4 CANADA  
 Phone: 905-624-0260  
 Fax: 905-624-5669



MODEL	TOTAL kW	NOMINAL AMPERES PER LINE		
		SINGLE PHASE		
		208V	240V	460V
36ES15	6.0	29	25	13
36ET15	6.0	29	25	13

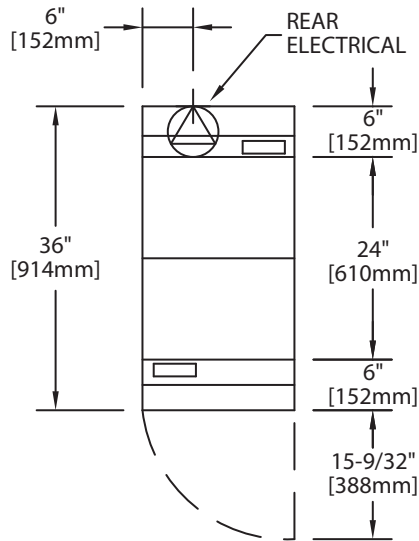

CLEARANCES			
ENTRY		TO COMBUSTIBLE WALL	
CRATED	UNCRAVED	SIDES	REAR
20-3/4" (527mm)	18-1/4" (464mm)	3" (76mm)	1/2" (13mm)

Shipping Information		
Model	Wt. Lb/Kg	Cu Ft
36ES15	255/116	28
36ET15		9

Garland products are not approved or authorized for home or residential use, but are intended for commercial applications only. Garland will not provide service, warranty, maintenance or support of any kind other than in commercial applications.

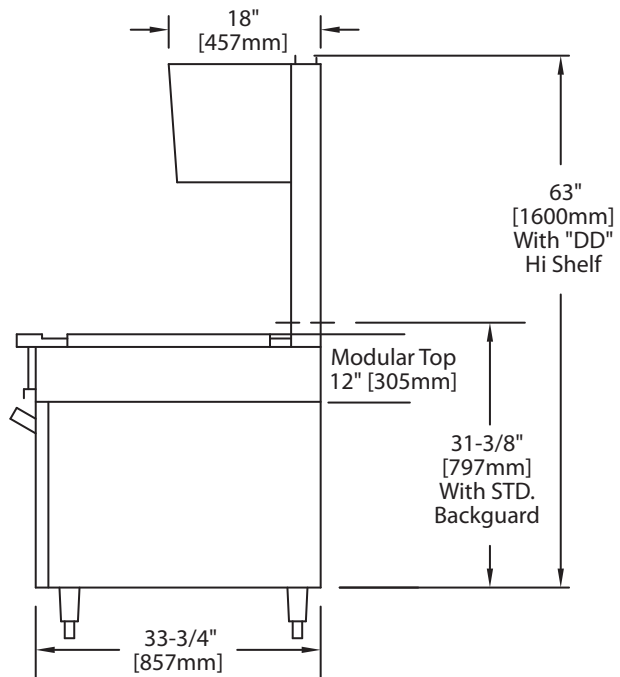
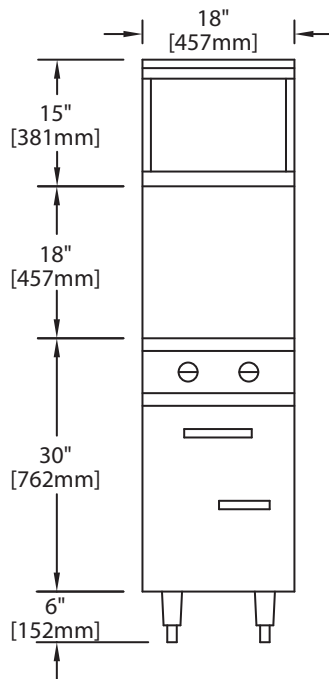

Form# 36ES15 (11/24/08)