



Featuring the  
**"Advanced Closed System +3"**

### ELECTRIC HEATED – Boilerless

#### Cooking Modes:

- Hot Air
- Retherm
- "Delta T" slow cooking
- Steam
- "Cook & Hold"
- "Crisp & Tasty"
- Combi

#### Cleveland Standard Features:

- "Advanced closed system" with "Crisp & Tasty" de-moisturizing feature
- Efficient heating system saves energy and provides fast heat up times
- Fully insulated cooking compartment for maximum energy savings
- Polished cooking compartment with coved corners for easy cleaning
- Four (4) 26" x 20" wire shelves
- Hinged fan guard and hinged removable pan racks
- Two (2) speed auto reversing convection fan for even heat distribution
- Space saving, easy to close **"Disappearing Door"**
- Door latch with safety vent position and wear-free door switch
- Vented, double glass door with integrated door stop and self draining condensate drip pan
- Easy to change, press-fit door seal
- Oven light with shock resistant safety glass
- Multipoint core temperature probe
- Easy to use electronic controls for all operational functions
- Self diagnostic system with full text message display
- Easy to understand menu icons with bright graphics display
- User friendly selector dial
- Exclusive **"Smart Key"** for selecting option settings
- Digital controls for temperature, time and core probe settings
- Eight (8) **"Press & Go"** one step, recipe start buttons
- Cook book library for up to 250 stored recipe programs, each recipe capable of 20 steps
- RS 232 connection for controlling one unit with a PC (personal computer)
- Memory module automatically saves unit settings and recipes
- Manual program override feature for operational settings
- Smooth action hand shower for compartment cleaning
- Injection system for steam

#### Options and Accessories

- ConvoClean hands free automatic compartment washing system
- PC-HACCP software for establishing "HACCP controls" and automatic documentation of the cooking process
- Equipment stand(s)
- Equipment stand(s) with Casters

**MODEL:**  OES-6.20

**CAPACITY:** Seven (7) - 18" by 26" by 1" full size sheet pans\* or  
 Fourteen (14) - 13" by 18" by 1" half size sheet pans\* or  
 Fourteen (14) - 12" x 20" by 2 1/2" steam table pans  
 \*On wire racks. Additional wire racks required for maximum capacity.



#### Short Form Specifications

Shall be Cleveland Model: OES-6.20 Combination Convection Oven / Steamer with simple to operate electronic programmable controls for Hot Air, Convection Steam, and Combination cooking modes, **"Cook & Hold"** and **"Delta T"** slow-cooking capabilities, **"Advanced Closed System"** with **"Crisp & Tasty"** de-moisturizing feature. Multiple cooking stage programs, stored recipe library, multipoint core temperature probe, **"Press & Go"**, one-step recipe start buttons, **"Smart Key"** for selecting option settings, two (2) speed auto reversing convection fan, boilerless. **"Disappearing Door"**. Capacity for seven (7) 18" x 26" full size sheet pans, or fourteen (14) 12" x 20" x 2 1/2" pans.

- Universal pan-rack system to hold full size sheet pans without the use of wire shelves
- Stacking kit for stacking two (2) OES-6.20 models
- Stacking kit for mounting one (1) OES-6.20 model on top of one (1) OES-10.20
- Lockable cover over operating controls for prison installations
- RS 485 connection for networking and controlling up to 32 units with a personal computer
- Plate rack for banquet operations
- Plate rack cart
- Thermal cover for plate or pan rack
- ConvoClean compartment cleaning solution
- ConvoRinse compartment rinse cycle solution
- "Dissolve" generator descaling solution
- Chicken Grill Rack
- 12" x 20" Wire Baskets for frying products
- Additional 26" x 20" Wire Shelves
- Special Baking Rack System
- 480 volt option
- Kleensteam II Water Filters

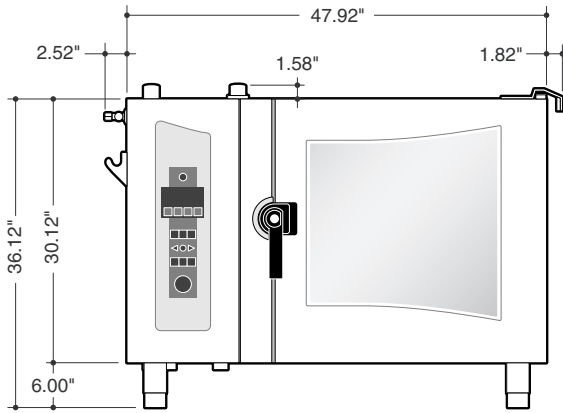

**FRONT VIEW**

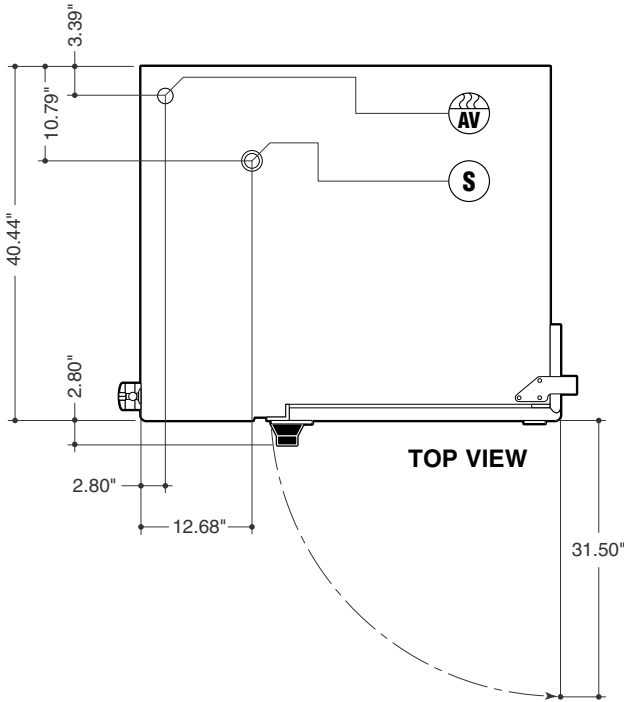

**TOP VIEW**

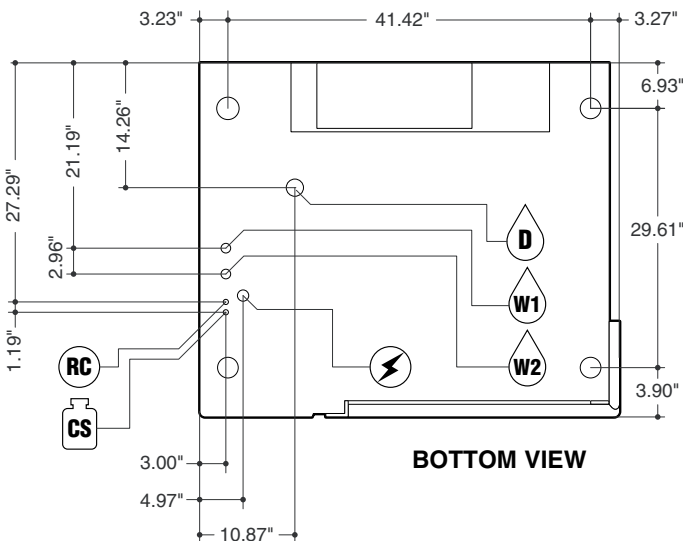

**BOTTOM VIEW**

**NOTES:**

Cleveland Range reserves right of design improvement or modification, as warranted.  
 Many regional, state and local codes exist and it is the responsibility of the owner and installer to comply with the codes.  
 Cleveland Range equipment is built to comply with applicable standards for manufacturers.

**The "Advanced Closed System" offers the following advantages:**

- Saves energy
- Automatic moisture level adjustment
- Low heat and steam emission to the kitchen
- Automatically regulated steam injection
- Enables immediate change into the steam mode
- "Crisp & Tasty" demisterizing function

**Model:** OES-6.20

**Pan Capacity** [Unit has 7 slide rails at 2.64" (67mm) apart]:

7 (20" x 26") full size wire racks	7 (18" x 26") full size sheet pans - <b>on wire racks</b>
14 (13" x 18") half size sheet pans - <b>on wire racks</b>	14 (12" x 20" x 2 1/2") steam table pans
14 (12" x 20" x 1") steam table pans	14 (12" x 20") frying Baskets - ( <b>no wire racks needed</b> )

**For Banquet Operations:** Optional Plate Rack holds 42 plates

**Unit Dimensions:** Width - 52.26", Depth - 43.24", Height - 36.82"

**Shipping Dimensions:** Width - 58", Depth - 49", Height - 45"  
 (including packaging)

**Shipping Weight:** 485 Lbs

**Required Clearances:** Rear - 2", Left Side - 4", Right Side - 2 1/2"

- Allow for sufficient distance if a "high heat source" (i.e. Broiler) is located next to the unit.
- Allow for sufficient clearance on left side for service access (contact the factory service department for recommendations).
- Installation must comply with all local fire and health codes.

**Agency Approvals:** UL, UL - Sanitation (NSF Standards)



<b>Electrical Requirements:</b>	208/3/60	240/3/60	440/3/60	480/3/60
Total Connected Load:	16.4 KW	21.6 KW	18.5 KW	22 KW
Hot Air:	14.7 KW	19.6 KW	16.5 KW	19.6 KW
Amps per Phase:	45.5	51.8	24.2	26.4

Do not connect to a G.F.I. outlet

**Water Connections:** Cold Water (drinking water quality)  
 Flow Pressure: 30 - 60 PSI  
 Water Inlets: 3/4" GHT-F (Female Garden Hose Connection)



Treated Water for Steam Production



Untreated Water for Condenser and Hand Shower



**Drain Connection:** 2" Tube

**Venting:** Exhaust Hood required



Air Vent



\*Connection for Cleaning Solution



\*Connection for Rinse Cycle



Low Pressure Safety Valve

\*Available as an option