



# W40A Food Mixer

Project \_\_\_\_\_  
 Item \_\_\_\_\_  
 Quantity \_\_\_\_\_  
 CSI Section 11400 \_\_\_\_\_  
 Approval \_\_\_\_\_  
 Date \_\_\_\_\_

W40A Food Mixer

## Models

W40A



## Standard Features

- Powerful 2 hp motor
- Variable speeds from 60 to 280 RPM
- By manually operating a single lever, the bowl raises and locks in position.
- Overload protection and no voltage release
- No bowl adaptors required for the down-size bowls
- #12 attachment hub with 198 rpm speed
- Locking pin on tools instead of shaft.
- Neoprene feet to minimize walking and rusting
- Permanently lubricated planetary head and attachment hub case
- 15-minute timer with HOLD feature
- Stainless steel 40-qt. bowl, wire whip and dough hook
- Alloy flat beater

## Options & Accessories

- 20-qt. bowl and accessories
- Bowl scraper in 40-qt. and 20-qt. sizes
- Stainless steel wing whip
- Pastry knife
- Bowl Truck with handle
- Vegetable slicer and shredder plates
- Meat grinder
- Mark IV programmable controls

## Specifications

### Mixing system

The VARIMIXER W40A is a planetary mixer with a variable speed drive system. The mixer frame consists of a column with welded-on feet, and a top traverse closed by a stainless steel cover. The bowl is mounted in bowl arms which are manually raised and locked simultaneously or lowered and opened, respectively. The column contains the motor and the bowl arm mechanism. The top traverse contains the transmission system consisting of the moveable pulleys, the intermediate belt drive and the planetary head. Start and stop push buttons are mounted on the frontplate along with a 15-minute electrical timer with a HOLD feature. Mixing tools are mounted in a bayonet shaft in the planetary head.

### Construction

Mixer frame of heavy-gauge, welded, rolled steel plate. Durable powder coated finish used on those surfaces not constructed of stainless steel. Top cover, splash apron and planetary head cap in heavy-gauge stainless steel. Molded PVC feet pads. Bowls in stainless steel. Mixing tools in cast aluminum or stainless steel. Bayonet shaft in stainless steel. Variable

speed V-belt transmission based on precision machined cast iron pulleys. Springloaded moveable pulleys in the variable speed drive for automatically adjusting of the tension of the special V-belt. Planetary mixer head of unique design. The planetary head revolves in heavy-duty ball and needle bearings around the main shaft. Precision milled beveled gear on the main shaft engages the bayonet shaft and the fixed internal gear ring through a double set of milled gears obtaining extra high torque capabilities of the mixing tools. Precision milled cast iron bowl arms lower and raise the bowl and clamp it in a precise position relative to the mixing tool allowing for small tolerances between tool extremities and the bowl. Attachment drive directly coupled to the motor securing maximum power output to the meat grinder or vegetable cutter. The 198 rpm high speed and the powerful motor give the meat grinder an unusually high capacity in relation to the size of the mixer.



5489 Campus Drive  
 Shreveport, LA 71129 USA

Tel: 318-219-7051  
 Tel: 1-800-222-1138  
 Fax: 318-635-3131  
 E-mail: mix@varimixer.com

[www.varimixer.com](http://www.varimixer.com)  
 Bulletin No. W40A 09/07

Enodis®

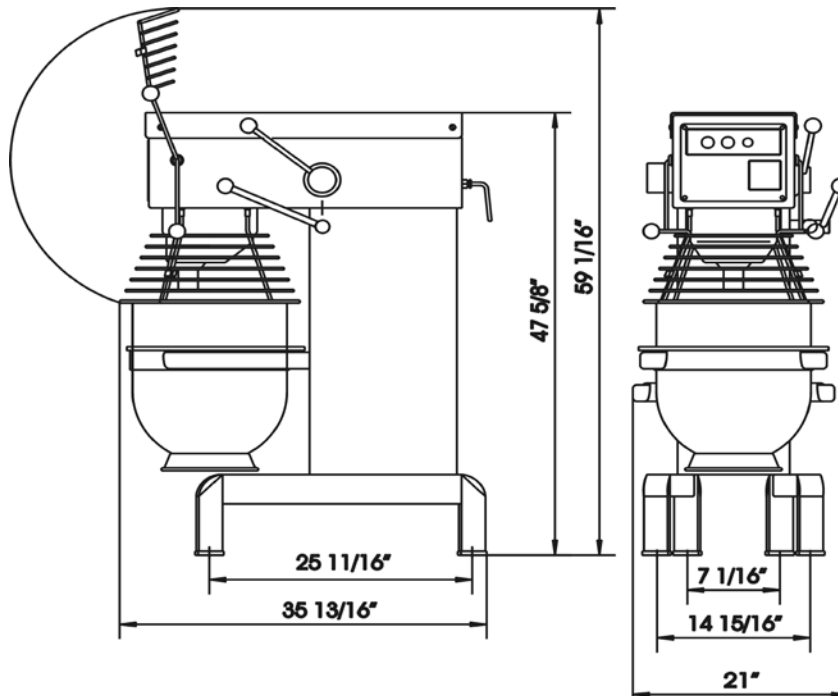

**DIMENSIONS**

MODEL NO.	CAPACITY	OVERALL SIZE (cm)			NET WEIGHT	SHIPPING INFORMATION					
		HEIGHT	WIDTH	LENGTH		WEIGHT	CLASS	CU. FT.	DIMENSIONS		
W40A	Large Bowl. 40-Qt. Small Bowl 20-Qt.	47 5/8" (120.97cm)	21" (53.34 cm)	35 13/16" (90.96 cm)	456 lbs. (206.84 kg)	536 lbs. (243.13 kg)	85	55	<b>H</b> 61" (154.94 cm)	<b>W</b> 32" (81.28 cm)	<b>L</b> 49" (124.4 cm)

**ELECTRICAL DATA FOR MOTOR\*\***

\*230VAC Supply/60 HZ/1 Phase  
 Wires (including. Ground) .....3  
 Motor Power.....HP.....2  
 Amperes, full load.....A ..... 10  
 No power cord included

\*208-240VAC Supply/60 HZ/3 Phase  
 Wires (including. Ground) .....4  
 Motor Power.....HP.....2  
 Amperes, full load.....A .....6  
 No power cord included

**MIXING SPEED**

Agitator Speed.....Min..... 60  
 Agitator Speed.....Max.....280  
 Attachment Hub .....RPM.....198

**%AR= weight of water**  
 weight of flour

Batch size and/or speed reduction is required if any of the following conditions exist.

1. High Gluten Flour
2. AR % under 40%
3. Water Temperature under 65 Degrees F

\*On the nominal motor voltage, + or - 10% tolerance is allowed.  
 \*\* Also available in 480/60/3, 380/50/3, 220/50/3, 220/50/1, - not submitted for UL listing.

**CAPACITY CHART**

Mashed Potatoes	Whip or Beater	30 lbs.
Whipped Cream	Whip	9 Qts.
Muffins	Beater	40 lbs.
Layer Cake	Beater	45 lbs.
Pie Dough	Pastry Knife	37 lbs.
Pancake Batter	Whip or Beater	16 Qts.
Cookie Dough	Beater or Hook	58 lbs.
Donuts, Yeast	Hook	42 lbs.
Donuts, Cake	Beater	41 lbs.
Bread Dough (65% AR)	Hook	45 lbs.
Pizza Dough (50% AR)	Hook	35 lbs.

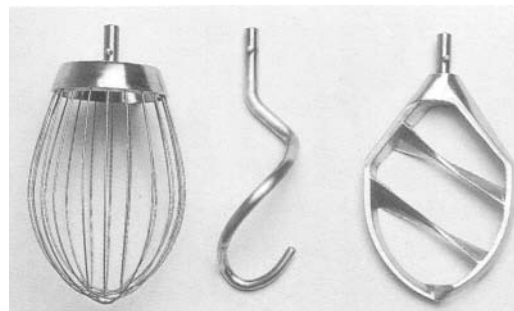

Standard tools: Whip, hook and beater.