



W60A Food Mixer

Project _____
 Item _____
 Quantity _____
 CSI Section 11400 _____
 Approval _____
 Date _____

W60A Food Mixer

Models

W60A



Standard Features

- Powerful 3 hp motor
- Variable speeds from 60 to 300 RPM
- By manually operating a single lever, the bowl raises and locks in position.
- Overload protection and no voltage release
- No bowl adaptors required for the down-size bowls
- #12 attachment hub with 198 rpm speed
- Locking pin on tools instead of shaft.
- Neoprene feet to minimize walking and rusting
- Permanently lubricated planetary head and attachment hub case
- 15-minute timer with HOLD feature
- Stainless steel 60-qt. bowl, wire whip and dough hook
- Alloy flat beater

Options & Accessories

- 30-qt. bowl and accessories
- Bowl scraper in 60-qt. and 30-qt. sizes
- Stainless steel wing whip
- Pastry knife
- Bowl Truck with handle
- Vegetable slicer and shredder plates
- Meat grinder
- Power Bowl Lift
- Mark IV programmable controls
- Ergo (tall column)

Specifications

Mixing system

The VARIMIXER W60A is a planetary mixer with a variable speed drive system. The mixer frame consists of a column with welded-on feet, and a top traverse closed by a stainless steel cover. The bowl is mounted in bowl arms which are manually raised and locked simultaneously - or lowered and opened, respectively. The column contains the motor and the bowl arm mechanism. The top traverse contains the transmission system consisting of the moveable pulleys, the intermediate belt drive and the planetary head. Start and stop push buttons are mounted on the frontplate along with a 15-minute electrical timer with a HOLD feature. Mixing tools are mounted in a bayonet shaft in the planetary head.

Construction

Mixer frame of heavy-gauge, welded, rolled steel plate. Durable powder coated finish used on those surfaces not constructed of stainless steel. Top cover, splash apron and planetary head cap in heavy-gauge stainless steel. Molded PVC feet pads. Bowls in stainless steel. Mixing tools in cast aluminum or stainless steel. Bayonet shaft in stainless steel. Variable

speed V-belt transmission based on precision machined cast iron pulleys. Springloaded moveable pulleys in the variable speed drive for automatically adjusting of the tension of the special V-belt. Planetary mixer head of unique design. The planetary head revolves in heavy-duty ball and needle bearings around the main shaft. Precision milled beveled gear on the main shaft engages the bayonet shaft and the fixed internal gear ring through a double set of milled gears obtaining extra high torque capabilities of the mixing tools. Precision milled cast iron bowl arms lower and raise the bowl and clamp it in a precise position relative to the mixing tool allowing for small tolerances between tool extremities and the bowl. Attachment drive directly coupled to the motor securing maximum power output to the meat grinder or vegetable cutter. The 198 rpm high speed and the powerful motor give the meat grinder an unusually high capacity in relation to the size of the mixer.



5489 Campus Drive
 Shreveport, LA 71129 USA

Tel: 318-219-7051
 Tel: 1-800-222-1138
 Fax: 318-635-3131
 E-mail: mix@varimixer.com

www.varimixer.com
 Bulletin No. W60A 09/07

Enodis®



W60A Food Mixer

Model # _____
CSI Section 11400

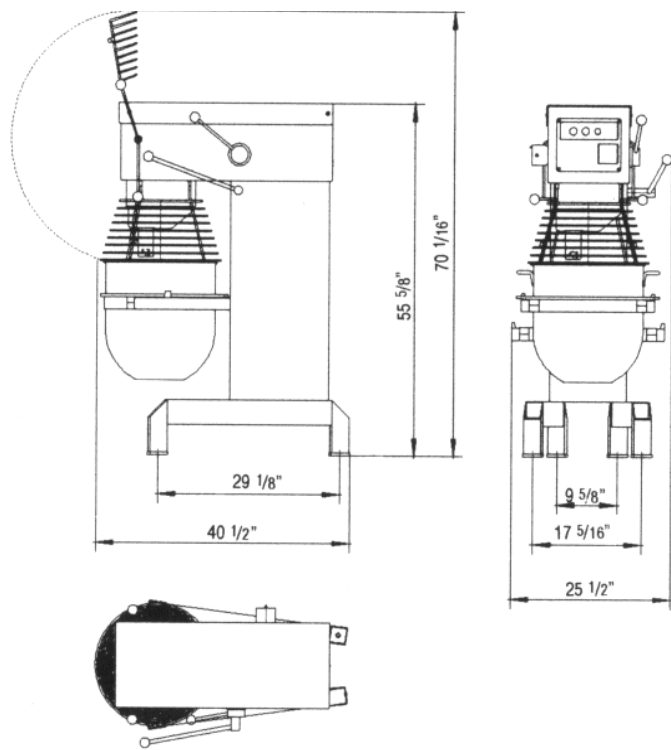

DIMENSIONS

MODEL NO.	CAPACITY	OVERALL SIZE (cm)			NET WEIGHT	SHIPPING INFORMATION					
		HEIGHT	WIDTH	LENGTH		WEIGHT	CLASS	CU. FT.	DIMENSIONS		
W60A	Large Bowl. 60-Qt. Small Bowl 30-Qt.	55 5/8" (141.288cm)	25 1/2" (64.77 cm)	40-1/2" (102.87 cm)	582 lbs. (263.99 kg)	707 lbs. (320.69 kg)	85	64	H 70" (177.80 cm)	W 32" (81.28 cm)	L 49" (124.4cm)

ELECTRICAL DATA FOR MOTOR**

*230VAC Supply/60 HZ/1 Phase
Wires (including. Ground)3
Motor Power.....HP.....3
Amperes, full load.....A 10
No power cord included

*208-240VAC Supply/60 HZ/3 Phase
Wires (including. Ground)4
Motor Power.....HP.....3
Amperes, full load.....A8
No power cord included

MIXING SPEED

Agitator Speed.....Min..... 60
Agitator Speed.....Max.....300
Attachment HubRPM.....198

%AR= $\frac{\text{weight of water}}{\text{weight of flour}}$

Batch size and/or speed reduction is required if any of the following conditions exist.

1. High Gluten Flour
2. AR % under 40%
3. Water Temperature under 65 Degrees F

*On the nominal motor voltage, + or - 10% tolerance is allowed.
**Also available in 480/60/3, 380/50/3, 220/50/3, 220/50/1, - not submitted for UL listing.

CAPACITY CHART

Mashed Potatoes	Whip or Beater	46 lbs.
Whipped Cream	Whip	12 Qts.
Muffins	Beater	60 lbs.
Layer Cake	Beater	69 lbs.
Pie Dough	Pastry Knife	58 lbs.
Pancake Batter	Whip or Beater	28 Qts.
Cookie Dough	Beater or Hook	58 lbs.
Donuts, Yeast	Hook	70 lbs.
Donuts, Cake	Beater	60 lbs.
Bread Dough (65% AR)	Hook	90 lbs.
Pizza Dough (50% AR)	Hook	75 lbs.

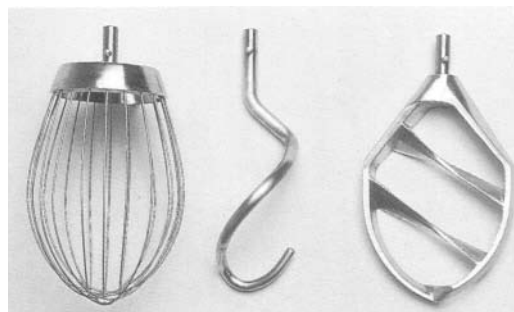

Standard tools: Whip, hook and beater.

5489 Campus Drive
Shreveport, LA 71129 USA

Tel: 318-219-7051
Tel: 1-800-222-1138
Fax: 318-635-3131
E-mail: mix@varimixer.com

www.varimixer.com
Bulletin No. W60A 09/07
Litho in U.S.A. ©Varimixer.

Enodis®