

Concepts™ Serving Systems

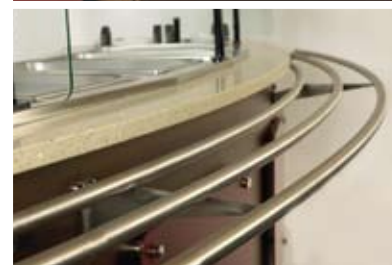

Hot off the runway & Fresh off the press!

Concepts™ is a leading-edge solution that breaks the mold on traditional serving lines.

Let your imagination run wild, break the mold and be inspired!

Start by using standard components. Add options, accessories and finishes that meet your needs. End with a serving solution that has the look and feel of a custom solution but without the custom price tag. That's the new Concepts line by Delfield. It's a whole new wave of serving line equipment.



1 Interchangeable décor panels: What's hot today may change tomorrow. With Delfield's new interchangeable décor panels, you can purchase new panels from Delfield and with standard tools; easily refresh the look. Changing a concept to fit with changing tastes has never been easier.



2 Low budget or sky's the limit? You decide. With varying levels of top materials, accessories and front finishes, you determine what your serving area needs to make it the next hot thing.



3 Unlimited panel options: Choose from thousands of standard laminate front finishes, custom laminates or even environmentally friendly 3form® Eco-Resin to create your signature look. Add stand-off panels to create an even more upscale serving area.



4 Curve Appeal: Generate excitement by adding curved counters into the mix. Delfield's new Concepts line has two different standard radius models and even more transition pieces to help you create a fresh look without breaking your budget.



5 Tray Slide: Available in different finishes to match your top décor, these tray slides add a lot of style. Choose from radius tubular tray slides, top extensions with runners independent fixed solid surface or granite or stainless steel solid "V" tray slides.



6 Sound construction: The new Concepts line features rugged galvanized construction with Sanalite® reinforced backs.



7 Kick it up: All Concepts lines are available with adjustable black laminate kick plates for easy floor alignment. Custom finishes are available.



8 Come together: Designed to be joined in the field, the Concept line features a spline joining system. This system makes the seams virtually disappear so all you see is one beautiful counter.



9 Flexibility first: Understanding menu dictates equipment, the Concepts line was developed for adaptability. By incorporating cutouts for warmers or Delfield's undercounter refrigerators, freezers, prep tables or reach ins you can easily roll different pieces in and out to make the most of your equipment.



10 On top: Top configurations include everything from stainless steel (even on the radius counters), to various manufacturers of solid surface materials, HanStone™ quartz material and even granite.



Signage

Delfield has a wide variety of signage options with standard configurations.



Including:

- Custom Graphics, Logos and Decals
- Lighting
- Heatlamps
- Standard Black Powdercoat (custom colors available)
- Different versions- angled, radial, etc.

We can create signage to meet your every need!



11 Sleek streamlined design: Ducted ventilation system eliminates the need for louvers. The result is a nice smooth, seamless finish that emphasizes the high style without compromising performance.



12 Inserts: Maximize productivity and efficiency by having everything you need in one location within reach. Refrigerated, heated or dry storage inserts available or roll in Delfield standard production pieces.



13 Highest standards: All of the Delfield Concepts serving systems have full NSF and UL listings. This ensures your serving line meets the strictest codes and adheres to all regulatory listings.



14 Electrical requirements: Various electrical options range from pre-wired to a breaker panel to an optional cord and plug on free standing single units.

Drop-In Options

The complete array of Delfield drop-ins are available to drop into the new Concepts line. This includes ice cooled cold pans, hot food wells, mechanically cooled cold pans, Delfield's patented LiquiTec® technology, frost tops and combination units. Creating the perfect serving counter has never been easier. Add dish dispensers, tray racks, napkin dispensers or cup dispensers to any serving line to make it the most efficient possible. Delfield's new Concepts line also has a complete offering of radius drop-ins to kick up the merchandising and appeal. Choose from hot, mechanically cooled or ice cooled cold pans to make your statement. Available in two to five pan capacities.



Concepts comes with the highest quality tops and laminates to customize your serving line to your vision.



A Top For Any Occasion.

The top of your serving line is the most expressive part of any station. Why leave it a simple stainless steel when you can have a custom granite, Corian®, HanStone™, Avonite™ or Zodiaq® top to set your serving counter apart from the rest. All of our tops are bought right from the manufacturer, so we can match your current top to create a seamless design throughout your establishment.

Custom Laminate Bases.

Delfield offers one of the widest available selection of laminates and solid surface panel options anywhere. You can pick from any of the traditional laminates as a base color from Wilsonart®, Formica®, Nevamar® and Pionite®. You can also chose to include offset panels from 3form®, a new company specializing in non-traditional solid surface products. If you are feeling really daring, cover your entire base with 3form®. The choice is up to you!

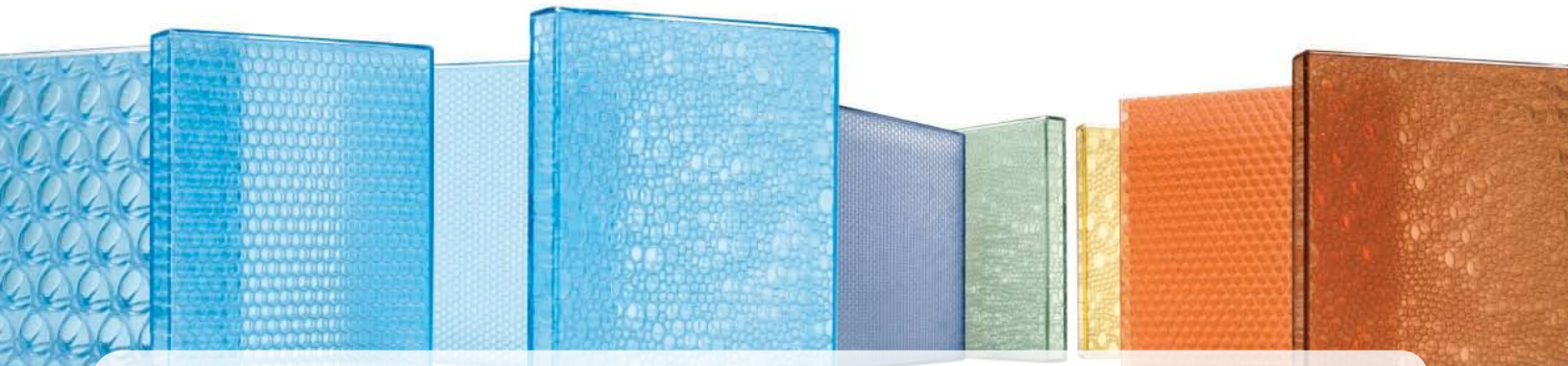

Offset Accent Panels

Add color, patterns and textures with resin panels that add an exciting new dimension to your serving counter. Use materials from companies like Formica®, 3form® and Wilsonart® to create a truly custom serving center.

500,000... Different configurations!

There are virtually thousands of different configurations you can create with the new Concepts line from Delfield. By starting with the standard blocks shown below, you can mix and match and come up with unique shapes to fit any space requirements.

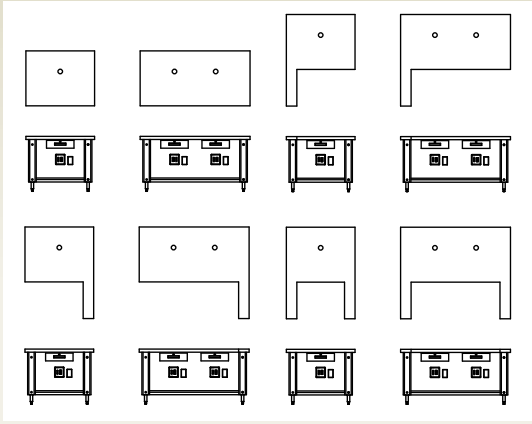

Cashier Counters:
Eight standard modules, single and double service options

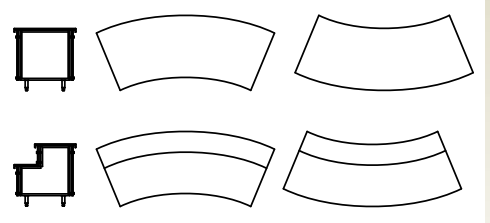

Radial Pieces: A set radius with two standard sizes

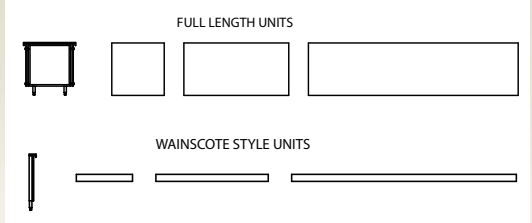

Linear Modules: Up to 120" in a single piece

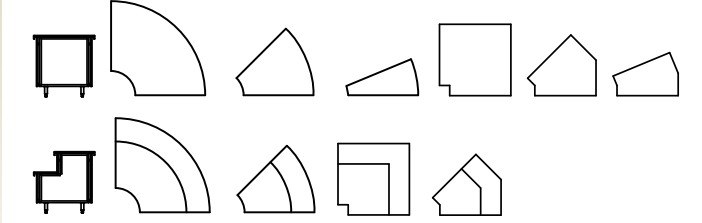

Transition Pieces: Various standard pieces to fit your merchandising needs

All of these pieces come together to create thousands of different configurations.



CONCEPTS INCORPORATES FLEXISHIELD™ FOOD SHIELDS

Delfield's new food shield line is designed to protect without getting in the way. The mostly glass design keeps food safe while enhancing the merchandising effect allowing your customers to get full view of what's important, the food! The new FlexiShield™ models give maximum menu and serving flexibility by allowing adjustment to three different glass positions. With several additional double and single tier, double and single service, sneeze guard and full front models also available to meet your needs. All designed to meet the upcoming 2011 NSF standard requirements.

This new food shield pivots into three positions allowing for a full range of serving options.



1. Fully closed: Perfect for serving over the top or to the side, this position is designed for operator served product.



2. Semi-open: This position allows you to serve under the food shield but limits range of access to the customer. This is designed for operator served product.



3. Open: Great for flexibility of pre-packaged product and self serve options, this food shield allows customer access to the product.



Radial Food shields to fit all radial bases and curves.

Available food shield options include black powdercoating, slim line lighting, stainless steel shelf, end glass and heat lamps.



NSF CODES: DELFIELD IS UP TO CODE!

Delfield has also taken steps to ensure the food shields meet the new NSF requirements which will be implemented in 2011. These new codes have significant impact on both the design and use. For example, all food shields will be required to have end glass. All second tier food shields must be completely enclosed and the dimensional requirements are substantially stricter than previous designs. Delfield has already considered all of the new requirements and all the new generation of food shields comply with the new standards.



SOLUTIONS

Delfield provides many of the operational solutions from Manitowoc Foodservice, a global company dedicated to bringing value to foodservice operators by equipping them with highly individualized real-world answers that enhance menus, service, profits and efficiency.



SERVICE

Delfield products are backed nationwide by STAR Service. This network of certified service agents provides fast response with factory-trained experts to assure your equipment will be fixed right the first time. STAR service agents guarantee their work and use genuine OEM parts for best equipment performance and longer life.

To learn how Manitowoc Foodservice and its leading brands can equip you, visit our global web site at www.manitowocfsg.com then find the regional or local resources available to you.

