

# 2011 Domestic U.S. Price Guide

Effective August 1st, 2011



# How to reach Delfield

## “Live” 800-733-8821

## International customers: +1 989-773-7981

Sales and customer support are available from 8:00 a.m. to 5:00 p.m. Eastern time, Monday through Friday.

If you know your parties extension, you may dial it at any time.

By dialing the direct extension that you need, our automated phone system allows you to bypass the operator.

### DIAL

**(800) 733-8948**  
or  
**+1 989-773-7981**

### THEN

#### PRESS 1

to dial by extension  
(listed to the right)

#### PRESS 2

for department

#### PRESS 3

for sales

#### PRESS 8

for parts

- The system will prompt you if necessary
- PRESS “0” (ZERO) FOR OPERATOR ASSISTANCE.

## Customer Service

12510 Jim Johnson Director of Customer Satisfaction

### Inside Sales

12507 Kim Tillotson Internal Sales Team Manager

12505 Kris Frayre Sales Engineering/Team Manager

12534 Jeff Galla Sales Engineering

12508 Karen Kreiner Sales Engineering/Team Manager

12523 Jon Lamont Sales Engineering

12503 Denise Maeder Internal Sales Representative

12520 Dave Mascho Sales Engineering

12511 Deanna Schafer Internal Sales Representative

12606 Kevin Salisbury Sales Engineering/Team Manager

12500 Pam Sharrar Sales Engineering

12509 Julie Shellenbarger Internal Sales Representative

12502 Melissa Sander Internal Sales Representative

12582 Anne Carson Sales Engineering

12652 Debbie Dickman Internal Sales Representative

12517 Bill Lybeer Sales Engineering

12582 Elizabeth Gray Internal Sales Representative

12586 Brent Bazaire Sales Engineering

12568 Julie Fox Sales Administrator

12512 Nancy Paulsen Sales Engineer

### Parts

12522 Patty Behrend Parts Supervisor

12504 Shelly Blizzard Parts Technician

12538 Kristi Freed Parts Technician

12530 Justin Nottingham Parts Technician

12529 Liz Gomez Parts Technician

12533 Nathon Lowery Parts Technician

12521 Desiree Evans Parts Technician

### Service

12541 Josh Sanders Service Technician

12535 Jeff Boakes Service Technician

12526 Chris McNett Service Technician

12537 Tim Roland Service Technician

12554 Katherine First Warranty Administrator

12589 Aaron Diegel Service Technician

12531 Cheryl Witrop Follow-up Coordinator

12514 Kevin Cotter Field Service Technician

### Installation

12650 Kevin McCormick Installation Supervisor

### Training

12549 Mike Hutchins Technical Trainer

©2011 The Delfield Company. All rights reserved. Reproduction is prohibited without written permission from The Delfield Company.

The information contained in this publication was accurate as of August 1, 2011. Delfield reserves the right to change specifications and/or pricing without notice.

Delfield is registered trademark, of The Delfield Company. All other trademarks and trade names are the properties of their respective owners, and are used for informational purposes only.

## Marketing

12506 Bill Keske Vice President of Marketing

12513 Sara Sunderman-Kirby

- Marketing Project Manager

XXXXX Jon O'Hern Product Manager

- Refrigeration

12608 Tim Wilczak Product Manager

- Fabrication / Engineered Solutions

12610 Marcy Mathews Product Manager

- Serving and Merchandising Systems

XXXXX Steve Willoughby Product Manager - Refrigeration

12632 Amanda Latta Sales & Marketing Administrator

12516 Jason Hartman Graphic Artist

12616 Amy Seaver Technical Writer

## Sales

12604 Bill Hoffman Director of Field Marketing Manager

12647 Jeff Michael Field Marketing Manager

XXXXX Jeff Herren Field Marketing Manager

## Credit Services

12545 Robert Howes Credit Manager

12544 Belinda Krisel Accounts Receivable Administrator

12539 Luanne Amrhein Accounts Receivable Analyst

12543 Stephanie Rydman Accounts Receivable Specialist

## Other Extensions

The operator can connect you to the person you need. Just press “0” (zero).

To access our technical service repair directly, call:

**(800) 733-8829**

**press 1 for Service**  
**and**  
**press 2 for Parts**

Visit us on the web at:  
**www.delfield.com**



## INDEX BY EQUIPMENT TYPE

An introduction to each product line precedes its pricing section.

### Accessories

Reach-Ins.....	12, 21-23
Blast Chiller/Shock Freezers.....	30
Undercounter Refrigerators and Freezers .....	34
Refrigerated and Freezer Work Tables.....	39
Prep Tables.....	46-47
Equipment Stands.....	50
E-Chef.....	54
Display Cases.....	59
Concepts.....	72-73
Serving Lines.....	83-86, 105-114, 125-128
Milk Coolers.....	130, 131, 133
Tray Make Up.....	135
Drop-Ins/Built-Ins.....	149
Mobile Dispensing Equipment.....	159

### Blast Chillers/Shock Freezers

#### Built Ins

Ice Cream Dispensers.....	138
Tray and Rack Dispensers .....	147
Milk or Beverage Dispensers .....	148
Milk and Ice Cream Dispensers.....	148

### Cashier Stands.....68, 81, 95, 104, 124

### Concepts™.....61-71

### Dish Dispensers

Drop In.....	145-146
Mobile Enclosed Frame.....	151-153

### Display Cases

Drop In.....	56-57
Heated.....	122
Refrigerated.....	56-58, 120-121

### Drop Ins

Cold Pans.....	71, 139, 140, 144, 142
Cold Slab.....	141
Combo Hot/Cold.....	142
Dish Dispensers.....	145-146
Display Cases.....	56-57
Freezer.....	138
Frost Tops.....	141
Heated Food Wells.....	71, 142-144
LiquiTec®.....	140
Sink, Faucets & Glass Fillers.....	138
Tray and Rack Dispenser .....	147
Water Station and Ice Storage.....	138

### E-Chef.....52-53

### Equipment Stands

Low Profile Refrigerated and Freezer Base.....	49
Versa Drawer.....	25

### FlexiShield Foodshields.....74-76

### Freezers

Bases.....	32-33, 36-37
Bases, Compact.....	32, 36
Bases, Front Breathing.....	33, 37
Drop In.....	138
Dual Temp.....	14
Equipment Stands.....	49
Pass-Thru.....	17
Reach-Ins.....	10-11, 16
Roll-ins.....	19
Serving Lines.....	118, 119
Undercounter.....	32-33
Work Tables.....	36-38
Versa Drawer.....	25

### Health Care Delivery Systems

Freestanding Mobile Air Curtain Refrigerator.....	136
Trim Line Make Up Counters.....	135

### Heated Units

Counters.....	61, 64, 78, 87, 96, 115, 135
Dish Dispensers.....	151-153, 155
Display Cases.....	122
Drop Ins Food Wells.....	71, 142-144
Food Table.....	52
Mobile Heated Serving Counters.....	78, 87, 96, 115, 135
Mobile Combo Hot/Cold Serving Counter.....	79, 89, 98, 117
Pass-Thrus.....	15
Roll-Ins.....	19
Roll-Thrus.....	20
Reach-Ins.....	15

### Kitchen EXCEleration Systems.....27

### Lettuce and Vegetable Spin Drier.....157

### Mark 7 Component Crafted Equipment.....5-8

### Milk Coolers.....130-133

### Milk and Ice Cream Dispensers

Built In Milk and Beverage.....	148
Free Standing Milk and Beverage.....	94, 103, 130, 131
Ice Cream and Milk & Ice Cream.....	82, 94, 103, 132, 133, 143

### Prep Tables.....41-45

### Rack Dispensers

Drop-In.....	147
Mobile.....	154-157

### Radial Drop-Ins.....144

### Refrigerators

Air Curtain.....	136
Bases.....	32-33, 36-38, 41-45
Bases, Compact.....	32, 36
Bases, Front Breathing.....	33, 37, 41-45
Bases, Salad Top.....	41, 43
Bases, Mega Top.....	42, 44
Display.....	56-58, 120-121
Drop In Food Wells.....	71, 144, 139, 142, 140
Dual Temp.....	14
Equipment Stands.....	49
Milk and Beverage.....	94, 103, 130, 131, 148
Mobile Serving Counter.....	62-63, 65-66, 78-79, 88-89, 91, 97, 98, 100, 116-118
Mobile Combo Hot/Cold Serving Counter.....	79, 89, 98, 117
Pass Thru.....	17
Reach-In.....	10-11, 13, 18
Roll In.....	19
Roll Thru.....	20
Work Table.....	36-38
Undercounter.....	32-33
Versa Drawer.....	25

### Serving Counters

All purpose.....	61, 64, 67, 70, 80, 82, 93, 95, 102, 104, 123, 124
Beverage.....	70, 92, 101
Combination Hot/Cold.....	79, 89, 98, 117
Combination Refrigerator/Freezer.....	118
Freezer.....	119
Frost Top.....	63, 80, 90, 99
Heated.....	16, 64, 78, 87, 96, 115, 135
Heated Display.....	122
Ice Cream.....	82, 94, 103, 132
Ice Pan.....	53, 62, 65, 79, 91, 100
Milk.....	94, 103, 132
Refrigerated.....	62, 63, 65, 66, 78, 87, 88, 116
Refrigerated Display.....	56-58, 120-121

### Tray Dispensers

Drop In/Built In.....	147
Mobile Cantilever Frame.....	154
Mobile Enclosed Frame.....	155
Mobile Open Frame.....	156-157
Stands.....	81, 95, 104

### Tray Make Up.....135-136

### Utility Carts.....158

### Work Tables.....36-38, 95, 104

### Undercounter.....32-33



***Chef's Counters  
Serving Systems  
Engineered Products***

***Infinite possibilities.***

***See back cover for listing of Delfield  
Representatives.***





# What is Delfield Mark 7 Component Crafted Equipment?

## Custom Fabrication With Standard Components

Delfield brings a different approach to custom fabrication. With any piece of equipment, such as utility storage, hot food table or glass rack cabinets, similar components are used. This holds true with freezers, refrigerators, prep tables, salad tables and so on. What Delfield has mastered is developing standard components that are consistent from job to job, year to year and month to month. What does this do for you? For one, the ability to purchase equipment that can be installed anywhere in the country and be assured it's the same each and every time. In addition, serviceability is increased due to common parts and labor is saved due to service technician's familiarity with the equipment. By developing common components in custom equipment Delfield is able to provide consistent pricing, no matter what time of year or how busy we happen to be.

Using the component crafted custom fabrication approach allows you to develop thousands of different equipment configurations while maintaining consistency throughout the equipment. Don't think for a minute this technique takes away from the quality of the equipment. It's quite the opposite, Delfield's ability to produce commonality in our equipment is a great value in many ways to our customer.

Delfield allows many of these components to be modified but remain similar in construction. This is the advantage of using Delfield over local custom fabrication. Our solid modeling capabilities, automated part demand flow, leading edge break presses, lasers and punches all give Delfield customers consistent precise products versus antiquated pencil marked, hand braked parts.

MARK 7 COMPONENT CRAFTED CUSTOM EQUIPMENT

CHEF'S COUNTERS



SERVING SYSTEMS







# DELFIELD MARK 7 COMPONENT CRAFTED EQUIPMENT

Start building your dream counter now! All of these units can be combined under one continuous top (up to 168" long) Each unit can be quickly splined together or field welded, for seamless appearance.

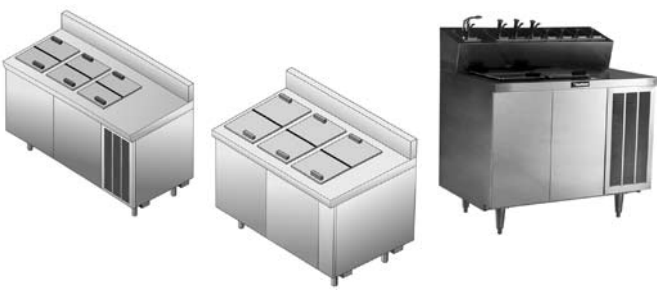
## GENERAL

- HFC-404A refrigerant
- All units can be provided with optional 14-gauge stainless steel tops.
- Special electrical requirements available on all units
- All refrigerators can be supplied remote or self contained





13 SERIES ICE CREAM CABINETS		<b>13 SERIES ICE CREAM CABINETS</b> <ul style="list-style-type: none"> <li>• Standard 16-gauge tops</li> <li>• 32" to 72" length</li> <li>• With or without syrup rail</li> <li>• Special rail lengths available</li> <li>• Sinks and dipperwells available</li> <li>• Lid locks available</li> <li>• Lexan covers available</li> <li>• Draft arms available</li> <li>• Drains</li> </ul>
14 SERIES HOT FOOD TABLES		<b>14 SERIES HOT FOOD TABLES</b> <ul style="list-style-type: none"> <li>• Standard 16-gauge tops</li> <li>• Electric or gas</li> <li>• Individually controlled or single tank water bath</li> <li>• Standard with drains and manifold</li> <li>• Optional cutting board</li> <li>• Optional auto fill</li> <li>• Optional LP gas regulator</li> </ul> <ul style="list-style-type: none"> <li>• Available in any length</li> </ul>
15 SERIES DISPLAY CASES		<b>15 SERIES DISPLAY CASES</b> <ul style="list-style-type: none"> <li>• Standard 16-gauge tops</li> <li>• 24" or 30" deep under display section</li> <li>• Mirror back, single service display with a see through display section with glass doors on both sides.</li> <li>• Available in 4' and 6' lengths</li> <li>• Optional locks</li> </ul> <ul style="list-style-type: none"> <li>• Optional additional shelves</li> <li>• Optional mirrored interior doors</li> </ul>
16 SERIES UTILITY STANDS		<b>16 SERIES UTILITY STANDS</b> <ul style="list-style-type: none"> <li>• Standard 16-gauge tops</li> <li>• Open shelf</li> <li>• Dry drawer</li> <li>• Hinged door</li> <li>• Sliding door</li> <li>• Available in any length</li> <li>• Optional door/drawer locks</li> <li>• Optional urn trough</li> <li>• 10 year drawer warranty</li> </ul>
17 SERIES EQUIPMENT STANDS		<b>17 SERIES EQUIPMENT STANDS</b> <ul style="list-style-type: none"> <li>• Standard 18-gauge tops</li> <li>• Standard maple cutting board</li> <li>• Open shelf</li> <li>• Dry drawer</li> <li>• Refrigerated &amp; freezer storage</li> <li>• Optional doors</li> <li>• Door/drawer locks</li> <li>• Freezers from 32" to 96"</li> <li>• Refrigerators from 36" to 110"</li> </ul> <ul style="list-style-type: none"> <li>• Available for bottom mounted ventilation</li> <li>• Full height sides and back for quick assembly into full equipment lineup</li> <li>• Feature Delfield's exclusive Full Extension Plus Drawer System</li> </ul>

# DELFIELD MARK 7 COMPONENT CRAFTED EQUIPMENT

## GENERAL

- HFC-404A refrigerant
- All units can be provided with optional 14-gauge stainless steel tops
- Special electrical requirements available on all units
- All refrigerators can be supplied remote or self-contained

MARK 7 COMPONENT CRAFTED EQUIPMENT

18 SERIES WORK TABLES		<p><b>18 SERIES WORK TABLES</b></p> <ul style="list-style-type: none"> <li>• Standard 16-gauge tops</li> <li>• Refrigerated or freezer models available</li> <li>• Optional 2 high and 3 high drawers</li> <li>• Available up to 126" with four door/drawer fronts</li> <li>• Optional tray racks</li> </ul>
18 SERIES SALAD & MEGA TOP		<p><b>18 SERIES SALAD AND MEGA TOP</b></p> <ul style="list-style-type: none"> <li>• Available from 36" to 132" with (4) base fronts</li> <li>• Optional pans and adapter bars</li> <li>• Number of pans to suit any need; 6 to 26 on salad tops and up to 42 on mega tops</li> <li>• Optional cover styles.</li> </ul>
18 SERIES PIZZA PREP & SANDWICH TABLES		<p><b>18 SERIES - PIZZA PREP AND SANDWICH TABLES</b></p> <ul style="list-style-type: none"> <li>• Available from 36" to 132" with (4) base fronts</li> <li>• Optional cutting boards</li> <li>• Optional 2 high and 3 high drawers</li> <li>• Optional locks available</li> <li>• Drain and gate valve available</li> <li>• Optional pans and adapter bars</li> <li>• Optional tray racks</li> </ul>
20, 21, 22 SERIES ADD ON UNITS		<p><b>20, 21, 22, SERIES TOP EXTENSIONS AND ADD ON UNITS</b></p> <ul style="list-style-type: none"> <li>• Available in any length and size</li> <li>• Top extensions</li> <li>• Dish rack and dispensers</li> <li>• Food warmers</li> <li>• Tilt out waste bins</li> <li>• Hinged door waste bin</li> <li>• Syrup tank storage cabinet</li> <li>• Oval tray storage</li> <li>• Build these units into any common top to come up with your desired length</li> </ul>

Finish your line off with any of the 357 options. Overshelves, finished backs and ends, tray slides, heat lamps, and outlets are all available to dress your counter. Make your vision a reality with Delfield Custom! Contact us at 800-733-8821 for a custom quote or pricing.

# HOW TO ORDER DELFIELD MARK 7 EQUIPMENT

## Need A Quote?

Delfield Sales ATTN: \_\_\_\_\_

Dealer ATTN: \_\_\_\_\_

### Field Quote Request

Project Name: \_\_\_\_\_

Bid Date: \_\_\_\_\_

Location: (City/State) \_\_\_\_\_

Install Date: \_\_\_\_\_

Consultant: \_\_\_\_\_

Phone Number: \_\_\_\_\_

Is Line Up:

Component Crafted Custom Equipment  Shelley

Refrigerated Units:

Self-contained  Remote

Hot Food Wells:

Individual  Open Bath

Hot Food Wells:

Electric  Gas

Pre Wired to:

Breaker Panel  J-Box

Are Drawings Available:

Plan  Elevation (scale)  Hand Sketch

Similar to a Job Previously Quoted:

Name: \_\_\_\_\_

Accessories Supplied and Installed by Delfield:  Yes

No

Customer Supplied/Installed by Delfield:  Yes

No

Field Installed by Customer:  Yes

No

Any Size Restrictions for Installation Site:

Max Size \_\_\_\_\_

Finish of Equipment:

S/S

Laminate

Is this a:

Quote Only

Quote and Drawing

### Key for labeling drawing:

A:  Dry Storage Unit

Refrigerated

B:  Raised Refrigerated Rail

Salad Opening

C:  Hot Food Wells

Mega Top Opening

D:  Pass-thru Storage

Refrigerated

E:  Dry Drawer

Roll Warmer  Refrigerated Drawers

F:  Overshelf

Single  Double Width: \_\_\_\_\_

G:  Microwave Shelf: Length: \_\_\_\_\_ Width: \_\_\_\_\_

H:  Outlets

Heat Lamps  Empty Baskets

I:  Hand Sink: Size: \_\_\_\_\_

J:  Production Units

K:  Top Extension

L:  Open Storage

Sliding Door



**6000XL™** - Reach-in refrigerators and freezers

**Specification Line®** - Reach-in, pass-thru, roll-in and roll-thru refrigerators, freezers and heated units



Reach-Ins

# 6000XL™ - REACH-IN REFRIGERATORS

## 6100XL™ - REACH-IN FREEZERS



6025XL-SH

### Product Information

- For solid door units, casters are installed from factory on two and three section units
- Delrite™ ABS interior liner
- Stainless steel exterior front and doors
- Digital thermometer
- Aluminum exterior sides
- Built in door locks-solid door units only
- Three epoxy coated shelves per section
- 10' cord and plug supplied
- Glass door units shipped flat on pallet with legs for field installation
- One year parts; one year labor; five year compressor, limited lifetime interior liner warranty. Additional warranty available, see below

### Specifications and Prices

MODEL NUMBER	DESCRIPTION	DIMENSIONS			STOR. CU. FT.	H.P.	AMPS	VOLTS	NEMA PLUG	SHIP WEIGHT	FREIGHT CLASS	LIST PRICE
		L	D	H								
<b>SOLID DOOR REFRIGERATORS</b>												
6025XL-S	One section Full height door	25.5"	32.60"	79.5"	20.0	1/4	6.0	115	5-15P	274	110	\$6,659
6025XL-SH	One section Half height door	25.5"	32.60"	79.5"	20.0	1/4	6.0	115	5-15P	274	110	\$7,348
6051XL-S	Two section Full height door	51"	32.60"	79.5"	43.5	1/3	8.0	115	5-15P	454	110	\$8,615
6051XL-SH	Two section Half height door	51"	32.60"	79.5"	43.5	1/3	8.0	115	5-15P	454	110	\$9,308
6076XL-S	Three section Full height door	76.5"	32.60"	79.5"	66.5	1/4,1/3	16.0	115	5-20P	622	110	\$12,592
6076XL-SH	Three section Half height door	76.5"	32.60"	79.5"	66.5	1/4,1/3	16.0	115	5-20P	622	110	\$13,305
MODEL NUMBER	DESCRIPTION	DIMENSIONS			STOR. CU. FT.	H.P.	AMPS	VOLTS	NEMA PLUG	SHIP WEIGHT	FREIGHT CLASS	LIST PRICE
		L	D	H								
<b>SOLID DOOR FREEZERS</b>												
6125XL-S	One section Full height door	25.5"	32.60"	79.5"	20.0	1/2	9.0	115	5-15P	274	110	\$7,937
6125XL-SH	One section Half height doors	25.5"	32.60"	79.5"	20.0	1/2	9.0	115	5-15P	274	110	\$8,633
6151XL-S	Two section Full height door	51"	32.60"	79.5"	43.5	3/4	12.0	115	5-15P	454	110	\$10,602
6151XL-SH	Two section Half height doors	51"	32.60"	79.5"	43.5	3/4	12.0	115	5-15P	454	110	\$11,279
6176XL-S	Three section Full height door	76.5"	32.60"	79.5"	66.5	1/2,3/4	20.0	120-208	14-20P	622	110	\$15,206
6176XL-SH	Three section Half height doors	76.5"	32.60"	79.5"	66.5	1/2,3/4	20.0	120-208	14-20P	622	110	\$15,909
MODEL NUMBER	DESCRIPTION	DIMENSIONS			STOR. CU. FT.	H.P.	AMPS	VOLTS	NEMA PLUG	SHIP WEIGHT	FREIGHT CLASS	LIST PRICE
		L	D	H								
<b>HINGED GLASS DOOR REFRIGERATORS**</b>												
6025XL-G	One section Full height door	25.5"	33.13"	80.5"	20.0	1/4	6.0	115	5-15P	338	110	\$7,885
6025XL-GH	One section Half height doors	25.5"	33.13"	80.5"	20.0	1/4	6.0	115	5-15P	338	110	\$8,679
6051XL-G	Two section Full height door	51"	33.13"	80.5"	43.5	1/3	8.0	115	5-15P	548	110	\$10,207
6051XL-GH	Two section Half height doors	51"	33.13"	80.5"	43.5	1/3	8.0	115	5-15P	548	110	\$10,998
6076XL-G	Three section Full height door	76.5"	33.13"	80.5"	66.5	1/4,1/3	16.0	115	5-20P	774	110	\$14,481
6076XL-GH	Three section Half height doors	76.5"	33.13"	80.5"	66.5	1/4,1/3	16.0	115	5-20P	774	110	\$15,274

\*\*Shipped flat on pallet with legs for field installation.

6000XL Series accessories and modifications can be found on pages 12.

#### Additional Warranty

Net Pricing  
Two year parts and labor contract --\$523





# 6000XL™-R - REMOTE REACH-IN REFRIGERATORS 6100XL™-R - REMOTE REACH-IN FREEZERS

## Product Information

- Stainless steel exterior front and doors
- Aluminum exterior sides
- Three epoxy coated shelves per section
- Built in door locks-solid door units only
- Delrite® ABS interior liner
- Digital thermometer
- 6" legs standard on all remote models
- Remote units supplied with: evaporator coil, solenoid valve, expansion valve and temperature control. Condensing units to be sized and supplied by others
- One year parts; one year labor; limited lifetime interior liner warranty. Additional warranty available, see below



6025XL-GR

## Specifications and Prices

MODEL NUMBER	DESCRIPTION	DIMENSIONS			STOR. CU. FT.	H.P.	AMPS	VOLTS	NEMA PLUG	SHIP WEIGHT	FREIGHT CLASS	LIST PRICE
		L	D	H								

### SOLID DOOR REFRIGERATORS - REMOTE

6025XL-SR	One section Full height door	25.5"	32.60"	80.5"	20.0	1/4	5.0	115	5-15P	274	110	\$6,350
6025XL-SHR	One section Half height door	25.5"	32.60"	80.5"	20.0	1/4	5.0	115	5-15P	274	110	\$7,011
6051XL-SR	Two section Full height doors	51"	32.60"	80.5"	43.5	1/3	5.0	115	5-15P	454	110	\$8,221
6051XL-SHR	Two section Half height doors	51"	32.60"	80.5"	43.5	1/3	5.0	115	5-15P	454	110	\$8,879
6076XL-SR	Three section Full height doors	76.5"	32.60"	80.5"	66.5	1/4,1/3	5.0	115	5-20P	622	110	\$11,442
6076XL-SHR	Three section Half height doors	76.5"	32.60"	80.5"	66.5	1/4,1/3	5.0	115	5-20P	622	110	\$12,087

MODEL NUMBER	DESCRIPTION	DIMENSIONS			STOR. CU. FT.	H.P.	AMPS	VOLTS	NEMA PLUG	SHIP WEIGHT	FREIGHT CLASS	LIST PRICE
		L	D	H								

### SOLID DOOR FREEZERS - REMOTE

6125XL-SR	One section Full height door	25.5"	32.60"	80.5"	20.0	1/2	5.0	115	5-15P	274	110	\$7,500
6125XL-SHR	One section Half height door	25.5"	32.60"	80.5"	20.0	1/2	5.0	115	5-15P	274	110	\$8,158
6151XL-SR	Two section Full height doors	51"	32.60"	80.5"	43.5	3/4	5.0	115	5-15P	454	110	\$10,110
6151XL-SHR	Two section Half height doors	51"	32.60"	80.5"	43.5	3/4	5.0	115	5-15P	454	110	\$10,760
6176XL-SR	Three section Full height doors	76.5"	32.60"	80.5"	66.5	1/2,3/4	5.0	115	(2)5-15P	622	110	\$13,945
6176XL-SHR	Three section Half height doors	76.5"	32.60"	80.5"	66.5	1/2,3/4	5.0	115	(2)5-15P	622	110	\$14,589

MODEL NUMBER	DESCRIPTION	DIMENSIONS			STOR. CU. FT.	H.P.	AMPS	VOLTS	NEMA PLUG	SHIP WEIGHT	FREIGHT CLASS	LIST PRICE
		L	D	H								

### HINGED GLASS DOOR REFRIGERATORS - REMOTE\*\*

6025XL-GR	One section Full height door	25.5"	33.13"	80.5"	20.0	1/4	5.0	115	5-15P	338	110	\$7,166
6025XL-GHR	One section Half height door	25.5"	33.13"	80.5"	20.0	1/4	5.0	115	5-15P	338	110	\$7,883
6051XL-GR	Two section Full height doors	51"	33.13"	80.5"	43.5	1/3	5.0	115	5-15P	548	110	\$9,272
6051XL-GHR	Two section Half height doors	51"	33.13"	80.5"	43.5	1/3	5.0	115	5-15P	548	110	\$9,990
6076XL-GR	Three section Full height doors	76.5"	33.13"	80.5"	66.5	1/4,1/3	5.0	115	5-20P	774	110	\$13,157
6076XL-GHR	Three section Half height doors	76.5"	33.13"	80.5"	66.5	1/4,1/3	5.0	115	5-20P	774	110	\$14,076

\*\*Shipped flat on pallet with legs for field installation.

6000XL Series accessories and modifications can be found on pages 12.

### Additional Warranty

Net Pricing  
Two year parts and labor contract --\$523



**6000XL™ - REACH-IN REFRIGERATORS ACCESSORIES**

**6100XL™ - REACH-IN FREEZERS ACCESSORIES**

**6000XL™-R - REMOTE REACH-IN REFRIGERATORS ACCESSORIES**

**6100XL™-R - REMOTE REACH-IN FREEZERS ACCESSORIES**

**Accessories and Modifications**

Non standard hinging -----	N/C
<b>AS000-AXD-0030</b> 6" legs (1 & 2 section, field installed) -----	\$119
<b>AS000-AXD-0031</b> 6" legs (3 section, field installed) -----	\$119
Casters on glass door units (per section) -----	\$476
<b>AS3978270</b> Additional one section epoxy coated shelf (or middle of 3 section) -----	\$81
<b>AS3978277</b> Additional left section epoxy coated shelf -----	\$81
<b>AS3978278</b> Additional right section epoxy coated shelf -----	\$81
<b>AS3977994</b> TR-8B Tray rack -----	\$312
<b>XL3105C</b> Stainless steel ends -----	\$1,360
<b>XL3102A</b> Stainless steel back (1 section) -----	\$802
<b>XL3102B</b> Stainless steel back (2 section) -----	\$1,431
<b>XL3102C</b> Stainless steel back (3 section) -----	\$2,150
<b>M3108B</b> Two half height solid doors in lieu of one full height solid door (per section) -----	\$736
<b>M3109B</b> Two half height glass doors in lieu of one full height glass door (per section) -----	\$819
<b>AS000-B88-0031</b> 220/60/1 voltage package (transformer shipped loose, not installed at factory) -----	\$1,285
<b>M3141A</b> 230/50/1 voltage package -----	\$850
<b>XL3135</b> Electronic control with Celsius readout -----	\$244



# SSR/SAR/SMR - REACH-IN REFRIGERATORS

## SSRN/SARN/SMRN - NARROW REACH-IN REFRIGERATORS

## SSRS/SARS/SMRS - SHALLOW REACH-IN REFRIGERATORS

### Product Information

- On-board high/low temp alarm
- All series standard with Delrite® ABS interior door liner
- Stainless steel interior and exterior (SS)
- Stainless steel exterior/aluminum interior (SA)
- Stainless steel front/aluminum sides and interior (SM)
- Built in door locks
- Digital thermometer
- Three wire shelves per section - SA/SS standard chrome plated shelves and SM standard with epoxy coated shelves.
- 10' cord and plug standard on all 115 volt units
- Environmentally friendly HFC-404A refrigerant
- All Specification Line models have a freight class of 110
- Two year parts and labor warranty; five year compressor warranty.



SSR2-G

### Specifications and Prices

MODEL NUMBER	OVERALL			STOR. CU. FT.	# OF SHLVs.	H.P.	SHIP WEIGHT	FULL HEIGHT SOLID	HALF HEIGHT SOLID	FULL HEIGHT GLASS	HALF HEIGHT GLASS
	L	D	H								
<b>REACH-IN REFRIGERATORS - HINGED DOORS-STANDARD WIDTH &amp; DEPTH</b>											
Stainless steel in and out											
SSR1	29"	34"	82"	24.96	3	1/4	418	\$12,956	\$13,346	\$13,724	\$14,130
SSR2	56"	34"	82"	51.92	6	1/3	650	\$17,495	\$18,037	\$19,021	\$19,616
SSR3	83"	34"	82"	78.89	9	1/2	830	\$24,068	\$24,781	\$26,366	\$27,159
Stainless steel out - aluminum in											
SAR1	29"	34"	82"	24.96	3	1/4	418	\$11,691	\$12,003	\$12,504	\$12,827
SAR2	56"	34"	82"	51.92	6	1/3	650	\$15,830	\$16,300	\$17,422	\$17,947
SAR3	83"	34"	82"	78.89	9	1/2	830	\$21,748	\$22,556	\$24,142	\$24,881
Stainless steel front - aluminum sides and interior											
SMR1	29"	34"	82"	24.96	3	1/4	418	\$7,705	\$8,218	\$10,838	\$11,120
SMR2	56"	34"	82"	51.92	6	1/3	650	\$11,068	\$12,326	\$15,100	\$15,555
SMR3	83"	34"	82"	78.89	9	1/2	830	\$15,734	\$17,605	\$21,335	\$21,990
<b>HINGED DOORS—NARROW WIDTH</b>											
Stainless steel in and out											
SSR1N	25"	34"	82"	20.97	3	1/4	398	\$12,956	\$12,997	\$13,384	\$13,783
SSR2N	48"	34"	82"	43.94	6	1/3	588	\$16,495	\$16,988	\$18,038	\$18,572
Stainless steel out - aluminum in											
SAR1N	25"	34"	82"	20.97	3	1/4	398	\$11,704	\$12,004	\$12,504	\$12,827
SAR2N	48"	34"	82"	43.94	6	1/3	588	\$14,906	\$15,368	\$16,507	\$17,005
Stainless steel front - aluminum sides and interior											
SMR1N	25"	34"	82"	20.97	3	1/4	398	\$10,345	\$10,610	\$11,051	\$11,336
SMR2N	48"	34"	82"	43.94	6	1/3	588	\$13,173	\$13,580	\$14,308	\$15,028
<b>HINGED DOORS—SHALLOW DEPTH</b>											
Stainless steel in and out											
SSR1S	29"	26"	82"	18.25	3	1/4	396	\$13,259	\$13,664	\$14,050	\$14,465
SSR2S	56"	26"	82"	37.96	6	1/3	586	\$16,928	\$18,037	\$19,021	\$19,615
SAR1S	29"	26"	82"	18.25	3	1/4	396	\$11,981	\$12,289	\$12,803	\$13,132
SAR2S	56"	26"	82"	37.96	6	1/3	586	\$15,259	\$15,731	\$16,896	\$17,410
SMR1S	29"	26"	82"	18.25	3	1/4	396	\$10,589	\$10,862	\$11,313	\$11,606
SMR2S	56"	26"	82"	37.96	6	1/3	586	\$13,486	\$13,903	\$14,931	\$15,386
<b>SLIDING DOORS</b>											
Stainless steel in and out											
SSR2	56"	34"	82"	51.92	6	1/3	670	\$22,277	\$22,958	\$22,277	\$22,958
SSR2S	56"	26"	82"	37.96	6	1/3	670	\$22,277	\$22,958	\$22,277	\$22,958
SAR2	56"	34"	82"	51.92	6	1/3	670	\$21,298	\$21,936	\$21,298	\$21,936
SAR2S	56"	26"	82"	37.96	6	1/3	670	\$21,298	\$21,936	\$21,298	\$21,936
SMR2	56"	34"	82"	51.92	6	1/3	670	\$18,822	\$19,387	\$18,459	\$19,013
SMR2S	56"	26"	82"	37.96	6	1/3	670	\$18,822	\$19,387	\$18,822	\$19,387

Specification Line Series accessories and modifications can be found on pages 21-23.

# SSD/SAD/SMD - REACH-IN & PASS-THRU DUAL TEMP UNITS



SSDRL2-SH

## Product Information

- On-board high/low temp alarm
- All series standard with Delrite® ABS interior door liner
- Stainless steel interior and exterior (SS)
- Stainless steel exterior/aluminum interior (SA)
- Stainless steel front/aluminum sides and interior (SM)
- Built in door locks
- Digital thermometer
- Three wire shelves per section - SA/SS standard chrome plated shelves and SM standard with epoxy coated shelves.
- 10' cord and plug standard on all 115 volt units
- Environmentally friendly HFC-404A refrigerant
- All Specification Line models have a freight class of 110
- Two year parts and labor warranty; five year compressor warranty.

## Specifications and Prices

MODEL NUMBER	OVERALL			STOR. CU. FT.	# OF SHLVs.	SHIP WEIGHT	H.P.	FULL HEIGHT SOLID	HALF HEIGHT SOLID	FULL HEIGHT GLASS	HALF HEIGHT GLASS
	L	D	H								
<b>REACH-IN REFRIGERATOR/FREEZER COMBINATIONS - DUAL TEMPS -HINGED DOORS-STANDARD WIDTH &amp; DEPTH</b>											
Stainless steel in and out											
SSDTR1	29"	34"	82"	11.52*	4	525	R-1/5, F-1/3	-	\$16,455	-	\$20,849
SSDBR1	29"	34"	82"	11.52*	4	525	R-1/5, F-1/3	-	\$16,455	-	\$20,849
SSDRL2	56"	34"	82"	24.96*	6	730	R-1/4, F-1/2	\$21,632	\$22,282	\$22,472	\$24,227
SSDFL2	56"	34"	82"	24.96*	6	730	R-1/4, F-1/2	\$21,632	\$22,282	\$22,472	\$24,227
Stainless steel out - aluminum in											
SADTR1	29"	34"	82"	11.52*	4	525	R-1/5, F-1/3	-	\$14,603	-	\$18,953
SADBR1	29"	34"	82"	11.52*	4	525	R-1/5, F-1/3	-	\$14,603	-	\$18,953
SADRL2	56"	34"	82"	24.96*	6	730	R-1/4, F-1/2	\$19,183	\$19,755	\$20,100	\$21,769
SADFL2	56"	34"	82"	24.96*	6	730	R-1/4, F-1/2	\$19,183	\$19,755	\$20,100	\$21,769
Stainless steel front - aluminum sides and interior											
SMDTR1	29"	34"	82"	11.52*	4	525	R-1/5, F-1/3	-	\$13,154	-	\$17,073
SMDBR1	29"	34"	82"	11.52*	4	525	R-1/5, F-1/3	-	\$13,154	-	\$17,073
SMDRL2	56"	34"	82"	24.96*	6	730	R-1/4, F-1/2	\$17,282	\$17,796	\$18,108	\$19,611
SMDFL2	56"	34"	82"	24.96*	6	730	R-1/4, F-1/2	\$17,282	\$17,796	\$18,108	\$19,611

MODEL NUMBER	OVERALL			STOR. CU. FT.	# OF SHLVs.	SHIP WEIGHT	H.P.	FULL HEIGHT SOLID	HALF HEIGHT SOLID
	L	D	H						
<b>PASS-THRU REFRIGERATOR/FREEZER COMBINATIONS - DUAL TEMPS -HINGED DOORS-STANDARD WIDTH &amp; DEPTH</b>									
Stainless steel in and out									
SSDRP2	56"	36.25"	82"	24.96*	6	730	R-1/4, F-3/4	\$26,952	\$27,731
SSDFP2	56"	36.25"	82"	24.96*	6	730	R-1/4, F-3/4	\$26,952	\$27,731
Stainless steel out - aluminum in									
SADRP2	56"	36.25"	82"	24.96*	6	730	R-1/4, F-3/4	\$26,098	\$26,873
SADFP2	56"	36.25"	82"	24.96*	6	730	R-1/4, F-3/4	\$26,098	\$26,873
Stainless steel front - aluminum sides and interior									
SMDRP2	56"	36.25"	82"	24.96*	6	730	R-1/4, F-3/4	\$23,510	\$24,203
SMDFP2	56"	36.25"	82"	24.96*	6	730	R-1/4, F-3/4	\$23,510	\$24,203

Glass door models have a glass door on one side and a solid door on the other.

\*Each sections capacity

Specification Line Series accessories and modifications can be found on pages 21-23.

# SSH/SAH/SMH - REACH-IN HOT FOOD CABINETS SSHPT/SAHPT/SMHPT - PASS-THRU HOT FOOD CABINETS

## Product Information

- On-board high/low temp alarm
- Stainless steel interior and exterior (SS)
- Stainless steel exterior/aluminum interior (SA)
- Stainless steel front/aluminum sides and interior (SM)
- Built in door locks
- Digital thermometer
- Three chrome plated wire shelves per section
- 10' cord and plug standard on all 115 volt units
- Environmentally friendly HFC-404A refrigerant
- All Specification Line models have a freight class of 110
- Two year parts labor warranty; five year compressor warranty.



SSH2-S

## Specifications and Prices

MODEL NUMBER	OVERALL			STOR. CU. FT.	# OF SHLVs.	SHIP WEIGHT	FULL HEIGHT SOLID	HALF HEIGHT SOLID	FULL HEIGHT GLASS	HALF HEIGHT GLASS
	L	D	H							

### REACH-IN HOT FOOD CABINETS-HINGED DOORS-STANDARD WIDTH & DEPTH

Stainless steel in and out

SSH1	29"	34"	82"	24.96	3	418	\$10,984	\$11,313	\$11,771	\$12,439
SSH2	56"	34"	82"	51.92	6	650	\$15,982	\$16,446	\$17,550	\$18,891
SSH3	83"	34"	82"	78.89	9	830	\$22,444	\$23,300	\$24,796	\$26,808

Stainless steel out - aluminum in

SAH1	29"	34"	82"	24.96	3	418	\$9,921	\$10,248	\$10,710	\$11,388
SAH2	56"	34"	82"	51.92	6	650	\$14,433	\$14,872	\$16,018	\$17,371
SAH3	83"	34"	82"	78.89	9	830	\$20,185	\$20,868	\$22,558	\$24,589

Stainless steel front - aluminum sides and interior

SMH1	29"	34"	82"	24.96	3	418	\$7,302	\$8,167	\$9,109	\$9,686
SMH2	56"	34"	82"	51.92	6	650	\$10,599	\$11,109	\$13,624	\$14,774
SMH3	83"	34"	82"	78.89	9	830	\$17,165	\$17,751	\$19,185	\$20,910

### HINGED DOORS-NARROW WIDTH

Stainless steel in and out

SSH2N	48"	34"	82"	43.94	6	588	\$17,880	\$18,344		
-------	-----	-----	-----	-------	---	-----	----------	----------	--	--

Stainless steel out - aluminum in

SAH2N	48"	34"	82"	43.94	6	588	\$16,516	\$16,953		
-------	-----	-----	-----	-------	---	-----	----------	----------	--	--

Stainless steel front - aluminum sides and interior

SMH2N	48"	34"	82"	43.94	6	588	\$14,046	\$14,418		
-------	-----	-----	-----	-------	---	-----	----------	----------	--	--

MODEL NUMBER	OVERALL			STOR. CU. FT.	# OF SHLVs.	SHIP WEIGHT	FULL HEIGHT SOLID	HALF HEIGHT SOLID
	L	D	H					

### PASS THRU HOT FOOD CABINETS-HINGED DOORS-STANDARD WIDTH & DEPTH

Stainless steel in and out

SSHPT1	29"	36.25"	82"	26.96	3	398	\$13,099	\$13,592
SSHPT2	56"	36.25"	82"	51.92	6	650	\$19,431	\$20,011

Stainless steel out - aluminum in

SAHPT1	29"	36.25"	82"	26.96	3	398	\$11,735	\$12,094
SAHPT2	56"	36.25"	82"	51.92	6	650	\$17,401	\$17,934

Stainless steel front - aluminum sides and interior

SMHPT1	29"	36.25"	82"	26.96	3	398	\$10,373	\$10,688
SMHPT2	56"	36.25"	82"	51.92	6	650	\$15,382	\$15,850

Glass door models have a glass door on one side and a solid door on the other.

Specification Line Series accessories and modifications can be found on pages 21-23.

# SSF/SAF/SMF - REACH-IN FREEZERS

## SSFN/SAFN/SMFN - NARROW REACH-IN FREEZERS

## SSFS/SAFS/SMFS - SHALLOW REACH-IN FREEZERS



SSF1-G

### Product Information

- On-board high/low temp alarm
- All series standard with Delrite® ABS interior door liner
- Stainless steel interior and exterior (SS)
- Stainless steel exterior/aluminum interior (SA)
- Stainless steel front/aluminum sides and interior (SM)
- Built in door locks
- Digital thermometer
- Three wire shelves per section - SA/SS standard chrome plated shelves and SM standard with epoxy coated shelves.
- 10' cord and plug standard on all 115 volt units
- Environmentally friendly HFC-404A refrigerant
- All Specification Line models have a freight class of 110
- Two year parts and labor warranty; five year compressor warranty.

### Specifications and Prices

MODEL NUMBER	OVERALL			STOR. CU. FT.	# OF SHLVs.	H.P.	SHIP WEIGHT	FULL HEIGHT SOLID	HALF HEIGHT SOLID	FULL HEIGHT GLASS	HALF HEIGHT GLASS
<b>REACH-IN FREEZERS - STANDARD WIDTH &amp; DEPTH</b>											
Stainless steel in and out											
SSF1	29"	34"	82"	24.96	3	S-1/2, G-3/4	440	\$14,757	\$15,188	\$16,921	\$17,578
SSF2	56"	34"	82"	51.92	6	S-3/4, G-1	710	\$19,600	\$20,210	\$23,927	\$25,239
SSF3	83"	34"	82"	78.89	9	S-1,G-1	960	\$27,984	\$28,850	\$29,189	\$31,261
Stainless steel out - aluminum in											
SAF1	29"	34"	82"	24.96	3	S-1/2,G-3/4	440	\$13,068	\$13,474	\$15,213	\$15,863
SAF2	56"	34"	82"	51.92	6	S-3/4,G-1	710	\$17,383	\$17,913	\$21,668	\$22,966
SAF3	83"	34"	82"	78.89	9	S-1,G-1	960	\$24,829	\$25,579	\$26,071	\$28,123
Stainless steel front - aluminum sides and interior											
SMF1	29"	34"	82"	24.96	3	S-1/2,G-3/4	440	\$10,092	\$10,603	\$13,441	\$14,015
SMF2	56"	34"	82"	51.92	6	S-3/4,G-1	710	\$13,870	\$14,891	\$19,144	\$20,292
SMF3	83"	34"	82"	78.89	9	S-1,G-1	960	\$19,134	\$20,665	\$23,033	\$24,847
MODEL NUMBER	OVERALL			STOR. CU. FT.	# OF SHLVs.	H.P.	SHIP WEIGHT	FULL HEIGHT SOLID	HALF HEIGHT SOLID		
<b>REACH-IN FREEZERS - NARROW WIDTH</b>											
Stainless steel in and out											
SSF1N	25"	34"	82"	20.97	3	1/2	408	\$14,757	\$15,188		
SSF2N	48"	34"	82"	43.94	6	3/4	680	\$19,135	\$19,722		
Stainless steel out - aluminum in											
SAF1N	25"	34"	82"	20.97	3	1/2	408	\$13,068	\$13,474		
SAF2N	48"	34"	82"	43.94	6	3/4	680	\$16,960	\$17,513		
Stainless steel front - aluminum sides and interior											
SMF1N	25"	34"	82"	20.97	3	1/2	408	\$11,547	\$11,905		
SMF2N	48"	34"	82"	43.94	6	3/4	680	\$14,986	\$15,472		
MODEL NUMBER	OVERALL			STOR. CU. FT.	# OF SHLVs.	H.P.	SHIP WEIGHT	FULL HEIGHT SOLID	HALF HEIGHT SOLID		
<b>REACH-IN FREEZERS - SHALLOW DEPTH</b>											
Stainless steel in and out											
SSF1S	29"	26"	82"	18.25	3	1/2	406	\$15,105	\$15,531		
SSF2S	56"	26"	82"	37.96	6	3/4	676	\$19,588	\$20,441		
Stainless steel out - aluminum in											
SAF1S	29"	26"	82"	18.25	3	1/2	406	\$13,378	\$13,792		
SAF2S	56"	26"	82"	37.96	6	3/4	676	\$17,363	\$17,930		
Stainless steel front - aluminum sides and interior											
SMF1S	29"	26"	82"	18.25	3	1/2	406	\$11,820	\$12,186		
SMF2S	56"	26"	82"	37.96	6	3/4	676	\$15,341	\$15,841		

Specification Line Series accessories and modifications can be found on pages 21-23.





# SSRPT/SARPT/SMRPT - PASS-THRU REFRIGERATORS

## SSRPTS/SARPTS/SMRPTS - SHALLOW PASS-THRU REFRIGERATORS

### SSFPT/SAFPT/SMFPT - PASS-THRU FREEZERS

#### Product Information

- On-board high/low temp alarm
- All series standard with Delrite® ABS interior door liner
- Stainless steel interior and exterior (SS)
- Stainless steel exterior/aluminum interior (SA)
- Stainless steel front/aluminum sides and interior (SM)
- Built in door locks
- Digital thermometer
- Three wire shelves per section - SA/SS standard chrome plated shelves and SM standard with epoxy coated shelves.
- 10' cord and plug standard on all 115 volt units
- Environmentally friendly HFC-404A refrigerant
- All Specification Line models have a freight class of 110
- Two year parts and labor warranty; five year compressor warranty.



**SSRPT1-S**  
(shown with optional casters)

#### Specifications and Prices

MODEL NUMBER	OVERALL			STOR. CU. FT.	# OF SHLVs.	H.P.	SHIP WEIGHT	FULL HEIGHT SOLID	HALF HEIGHT SOLID	FULL HEIGHT GLASS	HALF HEIGHT GLASS
	L	D	H								
<b>PASS-THRU REFRIGERATORS -HINGED DOORS-STANDARD WIDTH</b>											
Stainless steel in and out											
SSRPT1	29"	36.25"	82"	26.64	3	S-1/4,G-1/3	455	\$15,068	\$15,536	\$16,596	\$17,111
SSRPT2	56"	36.25"	82"	55.42	6	1/2	700	\$22,265	\$22,934	\$25,333	\$26,111
SSRPT3	83"	36.25"	82"	84.19	9	S-1/2,G-3/4	972	\$30,393	\$31,288	\$34,995	\$36,038
Stainless out - Aluminum in											
SARPT1	29"	36.25"	82"	26.64	3	S-1/4,G-1/3	455	\$13,493	\$13,907	\$15,075	\$15,540
SARPT2	56"	36.25"	82"	55.42	6	1/2	700	\$19,935	\$20,536	\$23,092	\$23,795
SARPT3	83"	36.25"	82"	84.19	9	S-1/2,G-3/4	972	\$27,212	\$28,031	\$32,013	\$32,922
Stainless steel front - aluminum sides and interior											
SMRPT1	29"	36.25"	82"	26.64	3	S-1/4,G-1/3	455	\$12,038	\$12,409	\$13,451	\$13,867
SMRPT2	56"	36.25"	82"	55.42	6	1/2	700	\$17,789	\$18,325	\$20,604	\$21,233
SMRPT3	83"	36.25"	82"	84.19	9	S-1/2,G-3/4	972	\$23,427	\$24,156	\$27,710	\$28,520

MODEL NUMBER	OVERALL			STOR. CU. FT.	# OF SHLVs.	H.P.	SHIP WEIGHT	FULL HEIGHT SOLID	HALF HEIGHT SOLID
	L	D	H						
<b>PASS-THRU REFRIGERATORS -HINGED DOORS-SHALLOW DEPTH</b>									
Stainless steel in and out									
SSRPT1S	29"	28.25"	82"	18.25	3	1/3	455	\$15,425	\$15,905
SSRPT2S	56"	28.25"	82"	37.96	6	1/2	700	\$22,303	\$22,974
Stainless out - Aluminum in									
SARPT1S	29"	28.25"	82"	18.25	3	1/3	455	\$13,811	\$14,234
SARPT2S	56"	28.25"	82"	37.96	6	1/2	700	\$19,990	\$20,565
Stainless steel front - aluminum sides and interior									
SMRPT1S	29"	28.25"	82"	18.25	3	1/3	455	\$12,322	\$12,702
SMRPT2S	56"	28.25"	82"	37.96	6	1/2	700	\$17,836	\$18,353

MODEL NUMBER	OVERALL			STOR. CU. FT.	# OF SHLVs.	H.P.	SHIP WEIGHT	FULL HEIGHT SOLID	HALF HEIGHT SOLID
	L	D	H						
<b>PASS-THRU FREEZERS-HINGED DOORS-STANDARD WIDTH</b>									
Stainless steel in and out									
SSFPT1	29"	36.25"	82"	26.64	3	3/4	672	\$16,748	\$17,176
SSFPT2	56"	36.25"	83"	55.42	6	1	1001	\$24,945	\$25,564
SSFPT3	83"	36.25"	85"	84.19	9	1 1/2	1268	\$35,820	\$37,098
Stainless out - Aluminum in									
SAFPT1	29"	36.25"	82"	26.64	3	3/4	672	\$15,111	\$15,536
SAFPT2	56"	36.25"	83"	55.42	6	1	1001	\$22,999	\$23,843
SAFPT3	83"	36.25"	85"	84.19	9	1 1/2	1268	\$34,001	\$35,268
Stainless steel front - aluminum sides and interior									
SMFPT1	29"	36.25"	82"	26.64	3	3/4	672	\$13,352	\$13,727
SMFPT2	56"	36.25"	83"	55.42	6	1	1001	\$20,320	\$21,065
SMFPT3	83"	36.25"	85"	84.19	9	1 1/2	1268	\$30,038	\$31,162

Glass door models have a glass door on one side and a solid door on the other.

Specification Line Series accessories and modifications can be found on pages 21-23.

SPECIFICATION LINE® SERIES

# SSRFF - FISH DRAWER REACH-INS

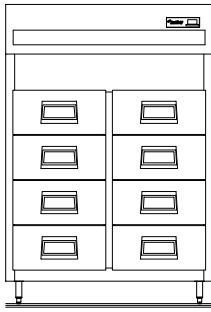

SSRFF2

## Product Information

- On-board high/low temp alarm
- All series standard with Delrite® ABS interior door liner
- Stainless steel interior and exterior (SS)
- Stainless steel exterior/aluminum interior (SA)
- Stainless steel front/aluminum sides and interior (SM)
- Built in door locks
- Digital thermometer
- 10' cord and plug standard on all 115 volt units
- Environmentally friendly HFC-404A refrigerant
- All Specification Line models have a freight class of 110
- Two year parts and labor warranty; five year compressor warranty.

## Specifications and Prices

MODEL NUMBER	OVERALL			STOR. CU. FT.	# OF SHLVs.	H.P.	SHIP WEIGHT	FULL HEIGHT SOLID
	L	D	H					
<b>FISH DRAWER REACH-IN - FOUR FISH DRAWERS PER SECTION</b>								
Stainless steel in and out								
SSRFF1	29"	34"	82"	24.96	N/A	1/4	418	<b>\$17,099</b>
SSRFF2	56"	34"	82"	51.92	N/A	1/3	650	<b>\$25,859</b>

Specification Line Series accessories and modifications can be found on pages 21-23.

No electrical options available for models on this page.

\* Limited accessories available for fish file units - please contact factory.

\*\* Connection to floor drain required by operator.

# SSRRI/SARRI/SMRRI - ROLL-IN REFRIGERATORS

## SSFRI/SAFRI/SMFRI - ROLL-IN FREEZERS

### SSHRI/SAHRI/SMHRI - HOT FOOD ROLL-INS

#### Product Information

- On-board high/low temp alarm
- All series standard with Delrite® ABS interior door liner (refrigerator & freezer units only)
- Stainless steel interior and exterior (SS)
- Stainless steel exterior/aluminum interior (SA)
- Stainless steel front/aluminum sides and interior (SM)
- Built in door locks
- Digital thermometer
- 10' cord and plug standard on all 115 volt units
- New lower ramp height
- Environmentally friendly HFC-404A refrigerant
- All Specification Line models have a freight class of 110
- Two year parts and labor warranty; five year compressor warranty.



SSRRI2-S

#### Specifications and Prices

MODEL NUMBER	OVERALL L	D	H	STOR. CU. FT.	# OF SHLVs.	H.P.	SHIP WEIGHT	FULL HEIGHT SOLID	FULL HEIGHT GLASS
<b>ROLL-IN REFRIGERATORS</b>									
Stainless steel in and out									
SSRRI1	34"	34"	89"	36.15	N/A	S-1/4,G-1/3	476	\$12,603	\$14,048
SSRRI2	66"	34"	89"	74.72	N/A	S-1/3,G-1/2	768	\$17,178	\$20,071
SSRRI3	98"	34"	89"	113.28	N/A	S-1/2,G-3/4	1044	\$23,252	\$28,594
Stainless out - aluminum in									
SARRI1	34"	34"	89"	36.15	N/A	S-1/4,G-1/3	476	\$12,196	\$13,756
SARRI2	66"	34"	89"	74.72	N/A	S-1/3,G-1/2	768	\$16,612	\$19,737
SARRI3	98"	34"	89"	113.28	N/A	S-1/2,G-3/4	1044	\$22,475	\$28,246
Stainless steel front - aluminum sides and interior									
SMRRI1	34"	34"	89"	36.15	N/A	S-1/4,G-1/3	476	\$10,278	\$11,592
SMRRI2	66"	34"	89"	74.72	N/A	S-1/3,G-1/2	768	\$14,686	\$17,449
SMRRI3	98"	34"	89"	113.28	N/A	S-1/2,G-3/4	1044	\$18,939	\$23,802

MODEL NUMBER	OVERALL L	D	H	STOR. CU. FT.	# OF SHLVs.	H.P.	SHIP WEIGHT	FULL HEIGHT SOLID
<b>ROLL-IN FREEZERS</b>								
Stainless steel in and out								
SSFRI1	34"	34"	89"	36.15	N/A	1/2	497	\$17,154
SSFRI2	66"	34"	91"	74.72	N/A	1	824	\$25,518
SSFRI3	98"	34"	90"	113.28	N/A	1-1/2	1128	\$33,629
Stainless out - aluminum in								
SAFRI1	34"	34"	89"	36.15	N/A	1/2	497	\$15,484
SAFRI2	66"	34"	91"	74.72	N/A	1	824	\$22,639
SAFRI3	98"	34"	90"	113.28	N/A	1-1/2	1128	\$29,827
Stainless steel front - aluminum sides and interior								
SMFRI1	34"	34"	89"	36.15	N/A	1/2	497	\$13,951
SMFRI2	66"	34"	91"	74.72	N/A	1	824	\$20,394
SMFRI3	98"	34"	90"	113.28	N/A	1-1/2	1128	\$25,835

MODEL NUMBER	OVERALL L	D	H	STOR. CU. FT.	# OF SHLVs.	MAX WATTS	SHIP WEIGHT	FULL HEIGHT SOLID	FULL HEIGHT GLASS
<b>HOT FOOD ROLL-INS</b>									
Stainless steel in and out									
SSHRI1	34"	34"	89"	36.15	N/A	2160	459	\$12,886	\$14,106
SSHRI2	66"	34"	89"	74.72	N/A	3840	704	\$17,745	\$20,181
SSHRI3	98"	34"	89"	113.28	N/A	4272	1008	\$24,087	\$27,745
Stainless out - aluminum in									
SAHRI1	34"	34"	89"	36.15	N/A	2160	459	\$11,542	\$12,761
SAHRI2	66"	34"	89"	74.72	N/A	3840	704	\$15,890	\$18,328
Stainless steel front - aluminum sides and interior									
SMHRI1	34"	34"	89"	36.15	N/A	2160	459	\$10,201	\$11,279
SMHRI2	66"	34"	89"	74.72	N/A	3840	704	\$14,585	\$16,822

Specification Line Series accessories and modifications can be found on pages 21-23.

# SSRRT/SARRT/SMRRT - ROLL-THRU REFRIGERATORS

## SSHRT/SAHRT/SMHRT - HOT FOOD ROLL-THRUS



SSRRT1-S

### Product Information

- On-board high/low temp alarm
- All series standard with Delrite® ABS interior door liner (refrigerator & freezer units only)
- Stainless steel interior and exterior (SS)
- Stainless steel exterior/aluminum interior (SA)
- Stainless steel front/aluminum sides and interior (SM)
- Built in door locks
- Digital thermometer
- 10' cord and plug standard on all 115 volt units
- New lower ramp height
- Environmentally friendly HFC-404A refrigerant
- All Specification Line models have a freight class of 110
- Two year parts and labor warranty; five year compressor warranty.

### Specifications and Prices

MODEL NUMBER	OVERALL			STOR. CU. FT.	# OF SHLVs.	H.P.	SHIP WEIGHT	FULL HEIGHT SOLID
<b>ROLL-THRU REFRIGERATORS HINGED DOORS</b>								
Stainless steel in and out								
SSRRT1	34"	36.25"	89"	38.58	N/A	1/3	514	\$17,263
SSRRT2	66"	36.25"	91"	79.74	N/A	1/2	776	\$24,676
SSRRT3	98"	36.25"	91"	120.90	N/A	3/4	1116	\$32,282
Stainless steel out - Aluminum in								
SARRT1	34"	36.25"	89"	38.58	N/A	1/3	404	\$15,454
SARRT2	66"	36.25"	91"	79.74	N/A	1/2	736	\$22,098
SARRT3	98"	36.25"	91"	120.90	N/A	3/4	1056	\$28,904
Stainless steel front - aluminum sides and interior								
SMRRT1	34"	36.25"	89"	38.58	N/A	1/3	404	\$13,787
SMRRT2	66"	36.25"	91"	79.74	N/A	1/2	736	\$22,018
SMRRT3	98"	36.25"	91"	120.90	N/A	3/4	1056	\$28,803

MODEL NUMBER	OVERALL			STOR. CU. FT.	# OF SHLVs.	BTU	SHIP WEIGHT	FULL HEIGHT SOLID
<b>ROLL-THRU HOT FOOD CABINETS</b>								
Stainless steel in and out								
SSHRT1	34"	36.25"	89"	38.58	N/A	N/A	519	\$15,722
SSHRT2	66"	36.25"	89"	79.74	N/A	N/A	836	\$22,116
SSHRT3	98"	36.25"	89"	120.90	N/A	N/A	985	\$29,344
Stainless steel out - Aluminum in								
SAHRT1	34"	36.25"	89"	38.58	N/A	N/A	504	\$14,088
SAHRT2	66"	36.25"	89"	79.74	N/A	N/A	806	\$19,818
SAHRT3	98"	36.25"	89"	120.90	N/A	N/A	940	\$26,335
Stainless steel front - aluminum sides and interior								
SMHRT1	34"	36.25"	89"	38.58	N/A	N/A	504	\$12,453
SMHRT2	66"	36.25"	89"	79.74	N/A	N/A	806	\$17,518

Specification Line Series accessories and modifications can be found on pages 21-23.

# REACH-IN REFRIGERATORS/FREEZERS/HOT FOOD CABINETS PASS-THRU REFRIGERATORS/FREEZERS/HOT FOOD CABINETS DUAL TEMPS – OPTIONS

**Doors** - Please contact factory for available door options on our pass-thru offering

SLARP3108B	Half height solid stainless steel door pair in lieu of one full height hinged solid door -----	\$446
SLARPF3108B	Half height solid stainless steel door pair in lieu of one full height hinged solid door -----	\$445
SLARP3111A	Full height hinged glass door in lieu of one full height solid stainless steel hinged door-refrigerator & hot food Full size and shallow only -----	\$761
SLARPF3111A	Full height hinged glass door in lieu of one full height solid stainless steel door - freezer -----	\$968
SLARP3115A	Half height hinged glass door pair in lieu of one full height hinged stainless steel door - refrigerator & hot food Full size and shallow only -----	\$1,457
SLARPF3115A	Half height hinged glass door pair in lieu of one full height hinged stainless steel door - freezer Full size only -----	\$1,452
SLARP3109A	One half height hinged glass door in lieu of one half height hinged stainless steel door - refrigerator & hot food Full size and shallow only -----	\$371
SLARPF3109A	One half height hinged glass door in lieu of one half height hinged stainless steel door - freezer Full size only -----	\$727
SLARP3113B	Half height sliding glass doors in lieu of two half height stainless steel doors (1 set) - refrigerator only Full size and shallow only -----	\$2,124
SLARP3113C	Half height sliding glass doors in lieu of two half height hinged glass doors (1 set) - refrigerator only Full size and shallow only -----	\$558
SLARP3110	Stainless steel fixed panel in lieu of half height hinged stainless steel doors A-1 section ----- B-2 section ----- C-3 section -----	\$538 \$1,036 \$1,554
SLARP3139	Three drawers (holds (2) 12"x 20"x 6" pans) in lieu of one half height stainless steel doors Full size only -----	\$2,876
AS000-AB9-025K	Stainless steel interior door liner in lieu of ABS -----	N/C

## Cabinet options

SLARP3102	Stainless steel back with stainless steel louver A-1 section ----- B-2 section ----- C-3 section -----	\$883 \$1,773 \$2,658
SLARP3103	Stainless steel rear louver A-1 section ----- B-2 section ----- C-3 section -----	\$293 \$599 \$888
SLARP3114	Front or rear stainless steel kickplate A-1 section ----- B-2 section ----- C-3 section -----	\$727 \$1,455 \$2,181
SLARP3114	Laminate front or rear kickplate D-1 section ----- E-2 section ----- F-3 section -----	\$567 \$1,191 \$1,786
4" high stainless steel utility base	AS000-B6R-0030: 1 section ----- AS000-B6R-0031: 2 section ----- AS000-B6R-0032: 3 section -----	\$565 \$1,129 \$1,696

SLARP3151	Stainless steel end kickplate -----	\$357
SLARP3152	Heat shield end -----	\$721
AS000-BYT-0030	Stainless steel banking strip -----	\$263
AS000-BYT-0031	Stainless steel wall trim 8" wide A-1 piece ----- B-2 pieces -----	\$174 \$336
SLARP3106	Laminate door panel (standard laminates) A-Full door ----- B-Half door -----	\$1,097 \$649
SLARP3107	Laminate upper shroud (standard laminates) A-1 section ----- C-2 section ----- E-3 section -----	\$738 \$987 \$1,231
SLARP3104	Laminate back (standard laminates) A-1 section ----- B-2 section ----- C-3 section -----	\$1,392 \$2,793 \$4,183
SLARP3105B	Laminate sides, per side (standard laminates) -----	\$1,340
SLARP3135	Electronic control with Celsius readout -----	\$239

## Leg/Caster Options

6" polyurethane casters in lieu of legs (not available on glass door units)	AS000-AXD-0054 (1&2 section units) ----- AS000-AXD-0055 (3 section units) -----	\$335 \$503
6" flanged feet in lieu of standard legs	AS000-BGP-0030 (1&2 section units) ----- AS000-BGP-0031 (3 section unit) -----	\$469 \$705
Special 2" high stainless steel leg channel in lieu of legs for curb mount	AS000-BEZ-0030 1 section ----- AS000-BEZ-0031 2 section ----- AS000-BEZ-0032 3 section -----	\$544 \$1,185 \$1,772
SLARP3122H-1	Shipped with legs or casters mounted from factory (2 and 3 section only) -----	Add \$224/section

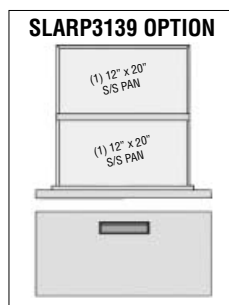

# REACH-IN REFRIGERATORS/FREEZERS/HOT FOOD CABINETS/DUAL TEMPS/PASS-THRU REFRIGERATORS/FREEZERS/HOT FOOD CABINETS/DUAL TEMPS – OPTIONS

## Shelf Options

Additional chrome plated shelf & clips

Hot Food-

AS000-B17-0031 (Standard) .....	\$97
AS000-B17-0035 (Shallow) .....	\$97
AS000-B17-0033 (Narrow) .....	\$97

Refrigerator/Freezer

AS000-B17-0030 (Standard) .....	\$97
AS000-B17-0034 (Shallow) .....	\$97
AS000-B17-0032 (Narrow) .....	\$97

Stainless steel shelf & clips

AS000-B17-0039 (Standard) .....	\$369
AS000-B17-0041 (Shallow) .....	\$369
AS000-B17-0040 (Narrow) .....	\$369

Chrome plated wine shelf

AS000-B17-0042 (Standard) .....	\$258
AS000-B17-0043 (Narrow) .....	\$258

Epoxy coated wire shelf (SM refrigerator and freezer models only)

AS000-B17-0036 (Standard) .....	\$79
AS000-B17-0037 (Shallow) .....	\$68
AS000-B17-0038 (Narrow) .....	\$68

Incandescent light for glass door models only (not available on heated units)

SLARP3159A - 1 section .....	\$857
SLARP3159B - 2 section .....	\$1,288
SLARP3159C - 3 section .....	\$1,631

## Slide Options

Not available for narrow or shallow width cabinets

TS1 - One pair 18"x26" pan flange support

AS000-B17-0057 .....	\$55/pair
----------------------	-----------

TS2 - One pair universal 12"x20" pan or 18"x26" pan bottom support

AS000-B17-0058 .....	\$102/pair
----------------------	------------

TS3 - One pair 12"x20" pan flange support

AS000-B17-0059 .....	\$55/pair
----------------------	-----------

TS4 - One pair rod type 18 levels 18"x26" flange support

AS000-B17-0060 .....	\$327/pair
----------------------	------------

TS5 - One pair 18"x26" pan bottom support

AS000-B17-0061 .....	\$64/pair
----------------------	-----------

TS6 - One pair 12"x20" pan bottom support

AS000-B17-0062 .....	\$64/pair
----------------------	-----------

3117 Deduction for chrome plated shelf.....\$78 each

3116 Deduction for epoxy coated shelf .....

## Refrigeration System/Electrical Options

Remote Systems (condensing unit by others)

1/5, 1/4, 1/3, 1/2 horsepower units .....	Deduct \$629
3/4 horsepower units .....	Deduct \$765
1 horsepower units.....	Deduct \$905

Water cooled refrigeration systems

1/5, 1/4, 1/3, 1/2 horsepower units .....	Add \$1,395
3/4 horsepower units .....	Add \$2,091
1 horsepower units.....	Add \$2,789

M3141A 230-50-1 Electrical.....	Add \$850
AS000-B88-0030 220-60-1 Electrical (refrigerator/freezer only) .....	Add \$1,260
(transformer shipped loose, not installed at factory)	
SLARP3144 Bottom mount electrical .....	Add \$536

## Correctional Package Options

SLARP3129A Mesh screen over top of unit.....\$373

SLARP3129D Security screws .....

SLARP3129H Single or double locking hasp clip (per door).....\$464

Coverless hinge .....

Pan slide welded in place  
Add to slide price .....

## Misc. Options

Unit set up for field rehingeability from factory .....

000-BZP-0040 KIT, REVERSE HINGING, REF/FRZ/HTD, SPEC-LINE .....





# ROLL-IN REFRIGERATORS/FREEZERS/HOT FOOD CABINETS/ DUAL TEMPS/ROLL-THRU REFRIGERATORS/FREEZERS/ HOT FOOD CABINETS/DUAL TEMPS – OPTIONS

## Doors

####	One full height hinged stainless steel Reach-In door on roll-through in lieu of one roll-in door -----	\$279
####	Two half height hinged stainless steel Reach-In doors on roll through in lieu of one roll in door -----	\$698
SLARP3111A	One full height hinged glass door in lieu of one full height solid stainless steel door - refrigerator & hot food only-----	\$761
AS000-AB9-025K	Stainless steel interior door liner in lieu of ABS -----	N/C

## Cabinet options

SLARR3102	Stainless steel back with stainless steel louver	
	A-1 section -----	\$928
	B-2 section -----	\$1,863
	C-3 section -----	\$2,791
SLARR3103	Stainless steel rear louver	
	A-1 section -----	\$293
	B-2 section -----	\$599
	C-3 section -----	\$888
SLARR3152	Heat shield end (per end) -----	\$721
AS000-BYT-0030	Stainless steel banking strip-----	\$263
AS000-BYT-0031	Stainless steel wall trim 8" wide	
	A-1 piece -----	\$174
	B-2 pieces -----	\$336
SLARR3106A	Laminate door panel (standard laminates)-----	\$1,097
SLARP3105B	Laminate sides, per side (standard laminates)-----	\$1,340
SLARR3107	Laminate upper shroud (standard laminates)	
	A-1 section -----	\$736
	B-2 section -----	\$996
	C-3 section -----	\$1,243
SLARR3104	Laminate back (standard laminates)	
	A-1 section -----	\$1,392
	B-2 section -----	\$2,793
	C-3 section -----	\$4,182
117-AFJ-0041	Flat ramp in lieu of inclined ramp -----	N/C
SLARP3135	Electronic control with Celsius readout -----	\$239

## Shelf Options

AS000-B17-0066	Half section chrome plated shelf kit (shelf supports, 2 shelves & clips) -----	\$844
AS000-B17-0065	Full section chrome plated shelf kit (shelf supports, 4 shelves & clips) -----	\$1,410
Additional chrome plated shelf & clips		
Hot Food-		
	AS000-B17-0031 (Standard)-----	\$97
Refrigerator/Freezer		
	AS000-B17-0030 (Standard) -----	\$97
Stainless steel shelf & clips		
	AS000-B17-0039 (Standard) -----	\$369
Epoxy coated wire shelf		
	AS000-B17-0036 (SM refrigerator and freezer models only) -----	\$79

## Refrigeration System/Electrical Options

Remote Systems (condensing unit by others)		
1/5, 1/4, 1/3, 1/2 horsepower units -----	Deduct \$629	
3/4 horsepower units -----	Deduct \$765	
1 horsepower units -----	Deduct \$905	
1 1/2 horsepower units-----	Deduct \$1,053	
Water cooled refrigeration systems		
1/5, 1/4, 1/3, 1/2 horsepower units -----	Add \$1,395	
3/4 horsepower units -----	Add \$2,091	
1 horsepower units -----	Add \$2,789	
1 1/2 horsepower units-----	Add \$3,486	
M3141A	230-50-1 Electrical-----	Add \$850
AS000-B88-0030	220-60-1 Electrical (refrigerator/freezer only) -----	Add \$1,260
<i>(transformer shipped loose, not installed at factory)</i>		

## Correctional Package Options

SLARR3129A	Mesh screen over top of unit-----	\$373
SLARR3129D	Security screws -----	\$167
SLARR3129H	Single or double locking hasp clip (per door)-----	\$464
Coverless hinge	-----	N/C

SPECIFICATION LINE® SERIES OPTIONS



**18600VD** - Freestanding  
Undercounter Multi-Temperature  
Refrigeration System

**F2900VD** - Freestanding Equipment  
Stand Multi-Temperature  
Refrigeration System



Versa Drawer™

# 18600VD SERIES FREESTANDING MULTI-TEMPERATURE REFRIGERATION

## F2900VD SERIES FREESTANDING MULTI-TEMPERATURE REFRIGERATION

### Product Information

#### All Versa Drawer Units

- 4 temperature operation—each drawer is completely independent and can operate as a refrigerator, freezer, chiller or thaw cabinet at any time
- Easy to use microprocessor control with push button function selection
- HACCP electronic record keeping, alarm notifications, and service diagnostics
- Heavy-gauge stainless steel top
- Mechanical access on compressor end of unit
- 32" heavy duty full extension drawers with (2) 12"x20"x6" pan capacity per drawer
- NSF 7 certified
- High density polyurethane foam throughout
- Dart style quick change gaskets
- 8' long electrical cord
- Environmentally friendly HFC-404A refrigerant
- One year parts, one year labor and 5 year compressor warranty

#### 18600 Series Only

- Standard on 6" casters
- Standard with stainless steel finished ends
- Standard at 34" ADA height
- Standard flat worktop

#### F2900VD Series Only

- Standard on 6" casters
- Standard with stainless steel finished ends
- Standard at 26" height
- Standard with full perimeter marine edge top

#### CE Models Only

- CE approved and listed



18682VDL



F2984VDL

**10-year Warranty on Delfield's Full Extension Drawer System Track!**

VDL - Left hand condensing unit.  
VDR - Right hand condensing unit.

### Specifications and Prices

Freestanding - 18600VD and F2900VD Series

Model Number	Description	Overall			32" Drawers	H.P.	Electrical	Amps	Nema Plug	Ship Weight lbs.	Freight Class	List Price
		L	D	H								
18650VDL	Worktop	50"	31.5"	34"	2	1/3	115/60/1	6.0	5-15	520	110	\$14,399
18650VDR	Worktop	50"	31.5"	34"	2	1/3	115/60/1	6.0	5-15	520	110	\$14,536
18682VDL	Worktop	82"	31.5"	34"	4	(2) 1/3	115/60/1	12.0	5-15	720	110	\$24,659
18682VDR	Worktop	82"	31.5"	34"	4	(2) 1/3	115/60/1	12.0	5-15	720	110	\$24,659
F2984VDL	Equipment Stand	84"	31.5"	26"	2	1/3	115/60/1	6.0	5-15	520	110	\$17,008
F2984VDR	Equipment Stand	84"	31.5"	26"	2	1/3	115/60/1	6.0	5-15	520	110	\$17,008
18650VDL-CE	Worktop	50"	31.5"	34"	2	1/3	230/50/1	3.6	BST1373	520	110	\$15,546
18650VDR-CE	Worktop	50"	31.5"	34"	2	1/3	230/50/1	3.6	BST1373	520	110	\$15,546
18682VDL-CE	Worktop	82"	31.5"	34"	4	(2) 1/3	230/50/1	7.2	BST1373	720	110	\$25,668
18682VDR-CE	Worktop	82"	31.5"	34"	4	(2) 1/3	230/50/1	7.2	BST1373	720	110	\$25,668
F2984VDL-CE	Equipment Stand	84"	31.5"	26"	2	1/3	230/50/1	3.6	BST1373	520	110	\$18,017
F2984VDR-CE	Equipment Stand	84"	31.5"	26"	2	1/3	230/50/1	3.6	BST1373	520	110	\$18,017



**F18RC119-ES1 -119" Pizza  
Production Center**



Kitchen EXCEleration™ Systems

## Product Information

### Standard Features

- Top is constructed of heavy-duty stainless steel
- High density environmentally friendly, Kyoto Protocol Compliant, Non ODP (Ozone Depletion Potential), Non GWP (Global Warming Potential) polyurethane foam throughout unit
- Snap-in dart style vinyl magnetic gaskets
- Recessed black plastic handle held in with a positive lock system
- 6.12" casters
- 8' long electrical cord
- 36" standard work height
- Composite cutting board
- Environmentally friendly HFC-404A refrigerant
- Built-in Lincoln CTI (Counter Top Impingment) oven

- Open shelf section for additional storage in base
- Overstructure with ambient topping rack and double tier landing area
- Ambient pan slides accommodate 18"x26" sheet pans

### Warranty

- One year parts and labor standard warranty
- Five year compressor warranty



**Pizza System**

## Specifications and Prices

MODEL NUMBER	DESCRIPTION	L	OVERALL D	H	H.P.	AMPS	NEMA PLUG	SHIP WEIGHT	LIST PRICE
F18RC119-ES1L	119" pizza production center, product workflow to the left	119" (302cm)	32" (81cm)	60" (152cm)	1/3	41.0	14-60	980lbs (445kg)	\$35,332
F18RC119-ES1R	119" pizza production center, product workflow to the right	119" (302cm)	32" (81cm)	60" (152cm)	1/3	41.0	14-60	980lbs (445kg)	\$35,332



**T Series - Blast Chiller/Shock Freezers**





## Product Information

- Blast chill food product from 200°F to 38°F in approximately 90 minutes
- Shock freeze food product from 200°F to 0°F in approximately 240 minutes
- On board integral printer—date, temperatures and times during all chilling cycles printed
- Automatic hot gas defrost
- Electronic control with 99 program capability and HACCP memory
- Time chill or temperature chill
- 1 core temperature probe
- Stainless steel exterior and interior
- Soft chill cycle for delicate foods
- Rehingable doors on T5 and T14D models
- T5 and T14D models have self-contained refrigeration systems
- T24C and T40 are supplied without condensing unit (condensing unit optional)
- T40 cabinet shipped “Knocked-down”, field assembly required
- Not available in 230/50/1
- Standard 1 year parts and labor, 5 year compressor warranty

## Specifications and Prices

MODEL NUMBER	DESCRIPTION	L	OVERALL D	H	CHILL CAPACITY	FREEZE CAPACITY	CONDENSING UNIT	SHIP WEIGHT	LIST PRICE
T5	Blast Chiller/Shock Freezer	31.5"	27.5"	37"-40"*	44lbs	26lbs	Self contained	275	\$20,083
T14D	Blast Chiller/Shock Freezer	31.5"	43.5"	71.7"	154lbs	120lbs	Self contained	650	\$40,265
T24C	Blast Chiller/Shock Freezer	49.25"	43.25"	60.25"	242	200	Remote	550	\$48,482
T40	Blast Chiller/Shock Freezer	61"	54"	89.5"	440	385	Remote	850	\$65,604
<b>Optional Condensing Units</b>									
T24CU	Condensing unit T24C	38.4"	30"	29.1"	-	-	Condensing unit	600	\$26,279
T40CU	Condensing unit T40	48"	36"	31"	-	-	Condensing unit	750	\$36,440
T24CUW	Water cooled condensing unit T24C	17"	39.9"	28"	-	-	Condensing unit	600	\$25,198
T40CUW	Water cooled condensing unit T40	17"	46"	30"	-	-	Condensing unit	750	\$34,937

\*Unit height 32" - 5" legs adjustable up to 8".



T5



T14D



T24C



T40

**T SERIES BLAST CHILLER/SHOCK FREEZER  
OPTIONS**



**Accessories and Modifications**

Trolley Guide for T14D allows use of ConvoTherm 6.20 or 10.10 rack (AS3239578) .....	\$1,348
Condensing unit weatherproof hood - (CUHOOD).....	\$3,970
ConvoTherm adapter mount for T5 model (AS3239579) .....	\$816
For use when 6.10 oven is mounted on top of the unit	
Casters for T5 model (AS000-AXD-0063)	
Shipped loose for field assembly .....	\$317
Casters for T14D model (AS000-AXD-0062)	
Shipped loose for field assembly .....	\$317





**400 Series** - Undercounter Refrigerator/ Freezer Bases

**UC4000 Series** - Undercounter Refrigerator/ Freezer Bases

**UC4400 Series** - Undercounter Refrigerator/ Freezer Bases

**UCD4400 Series** - Undercounter Refrigerator/ Freezer Bases with Drawers

**UC4500 Series** - Undercounter Freezer Bases



# 400 - UNDERCOUNTER REFRIGERATORS & FREEZERS

## UC4000 - UNDERCOUNTER REFRIGERATORS & FREEZERS



**406-CA**



**UC4048**

Shown with optional casters

### Product Information

#### 400 Series

- Features Delfield's exclusive Delrite ABS interior. ABS is extremely durable - it won't dent, chip or corrode and is backed by a limited lifetime warranty
- Stainless steel front, sides and top
- Two epoxy coated wire shelves, standard installed per unit
- Environmentally friendly R404A refrigerant
- Foamed in place polyurethane cuts energy costs
- Black recessed quick grip handle
- Rugged 6" high heavy duty metal legs (models 406 & 407 only) Units with a "CA" suffix are standard on 3" casters
- All units come standard hinged right and may be changed at the factory at no charge. Indicate when order is placed
- 7' cord and plug supplied

#### UC4000 Series

- Features Delfield's exclusive Delrite ABS interior. ABS is extremely durable - it won't dent, chip or corrode and is backed by a limited lifetime warranty
- Stainless steel front, sides and top
- Environmentally friendly R404A refrigerant
- Four epoxy coated wire shelves standard installed per unit
- Black recessed quick grip handle
- Rugged 6" high heavy duty metal legs
- Door hinging available on either right or left, right side is standard
- 6' cord and plug supplied
- One year parts and 90 day labor standard warranty. Additional warranties available, see below

### Specifications and Prices

MODEL NUMBER	DESCRIPTION	OVERALL			STOR. CU. FT.	H.P.	AMP	VOLTS	NEMA PLUG	SHIP WEIGHT	FREIGHT CLASS	LIST PRICE
		L	D	H								
<b>UNDERCOUNTER REFRIGERATOR BASES</b> with stainless steel top												
406	1 door	27.25"	28.5"	35.5"	5.7	1/5	4.0	115	5-15P	176	110	<b>\$3,816</b>
<b>UNDERCOUNTER FREEZER BASES</b> with stainless steel top												
407	1 door	27.25"	28.5"	35.5"	5.7	1/5	5.8	115	5-15P	176	110	<b>\$4,331</b>
<b>UNDERCOUNTER REFRIGERATOR OR FREEZER</b> with subtop and 3.75" casters												
406-CA	refrigerator	27.25"	27.75"	33.25"	5.7	1/5	4.0	115	5-15P	168	110	<b>\$3,638</b>
407-CA	freezer	27.25"	27.75"	33.25"	5.7	1/5	5.8	115	5-15P	168	110	<b>\$4,145</b>

MODEL NUMBER		OVERALL			STOR. CU. FT.	H.P.	AMP	VOLTS	NEMA PLUG	SHIP WEIGHT	FREIGHT CLASS	LIST PRICE
		L	D	H								
<b>48" UNDERCOUNTER REFRIGERATOR BASES</b> with stainless steel top												
UC4048	48"	28.5"	35.5"	11.4	1/5	4.0	115	5-15P	236	110		<b>\$5,539</b>
<b>48" UNDERCOUNTER FREEZER BASES</b> with stainless steel top												
UC4148	48"	28.5"	35.5"	11.4	1/3	5.8	115	5-15P	236	110		<b>\$6,146</b>

400 and 4000 accessories and modifications can be found on page 34.

#### Additional Warranties

Net Pricing

One year parts and labor contract --- \$279

Two year parts and labor contract -- \$523

Five year compressor warranty  
 1/5 H.P. ----- \$108  
 1/3 H.P. ----- \$128



# UC4400 - UNDERCOUNTER REFRIGERATORS UC4500 - UNDERCOUNTER FREEZERS

## Product Information

- All 4400 and 4500 Series units are 100% front breathing, which allows the unit to be pushed against a wall or built into a cabinet or an existing line up
- "D" prefix models feature Delfield's exclusive new drawer system. Drawers are backed by a 10-year warranty on the track assembly
- Durable, rugged stainless steel sides, top and front
- Features Delfield's exclusive Delrite ABS interior. ABS is extremely durable - it won't dent, chip or corrode and is backed by a limited lifetime warranty
- Heavy duty self-closing hinges
- Environmentally friendly R404A refrigerant
- High density foamed in place polyurethane keeps energy costs low
- Black recessed quick grip handle
- Standard on 3" casters for easy cleaning and installation
- Door hinging available on either right or left, right side is standard
- 6' cord and plug supplied
- One epoxy coated wire shelf, standard installed per door section
- One year parts and 90 day labor standard warranty. Additional warranties available, see below



UC4432N



UC4464N

UNDERCOUNTER REFRIGERATORS AND FREEZERS

## Specifications and Prices

MODEL NUMBER	DESCRIPTION	L	OVERALL D	H	VOL CU. FT.	H.P.	AMP	VOLTS	NEMA PLUG	SHIP WEIGHT	FREIGHT CLASS	LIST PRICE
<b>27" REFRIGERATED UNDERCOUNTER</b>												
UC4427N	one door	27"	31.5"	34.25"	5.7	1/5	3.9	115	5-15P	223	110	\$4,281
UCD4427N	two drawers	27"	31.5"	34.25"	5.7	1/5	3.9	115	5-15P	245	110	\$5,908
<b>32" REFRIGERATED UNDERCOUNTER</b>												
UC4432N	one door	32"	31.5"	34.25"	6.9	1/5	3.9	115	5-15P	245	110	\$5,250
UCD4432N	two drawers	32"	31.5"	34.25"	6.9	1/5	3.9	115	5-15P	293	110	\$6,827
<b>48" REFRIGERATED UNDERCOUNTER</b>												
UC4448N	two doors	48"	31.5"	34.25"	10.7	1/5	3.9	115	5-15P	316	110	\$5,587
UCD4448N	four drawers	48"	31.5"	34.25"	10.7	1/5	3.9	115	5-15P	398	110	\$8,700
<b>60" REFRIGERATED UNDERCOUNTER</b>												
UC4460N	two doors	60"	31.5"	34.25"	15.7	1/5	3.9	115	5-15P	411	110	\$6,606
UCD4460N	four drawers	60"	31.5"	34.25"	15.7	1/5	3.9	115	5-15P	495	110	\$9,700
<b>64" REFRIGERATED UNDERCOUNTER</b>												
UC4464N	two doors	64"	31.5"	34.25"	16.7	1/5	3.9	115	5-15P	421	110	\$7,184
UCD4464N	four drawers	64"	31.5"	34.25"	16.7	1/5	3.9	115	5-15P	522	110	\$10,285
<b>72" REFRIGERATED UNDERCOUNTER</b>												
UC4472N	three doors	72"	31.5"	34.25"	18.7	1/5	3.9	115	5-15P	461	110	\$7,752
UCD4472N	six drawers	72"	31.5"	34.25"	18.7	1/5	3.9	115	5-15P	545	110	\$11,541
<b>32" FREEZER UNDERCOUNTER</b>												
UC4532N	one door	32"	31.5"	34.25"	6.9	1/3	9.5	115	5-15P	245	110	\$5,945
UCD4532N	two drawers	32"	31.5"	34.25"	6.9	1/3+	12.0	115	5-15P	293	110	\$7,528
<b>60" FREEZER UNDERCOUNTER</b>												
UC4560N	two doors	60"	31.5"	34.25"	16.9	1/3	12.0	115	5-15P	411	110	\$8,045

**10-year Warranty on Delfield's Drawer System Track!**

400 and 4000 accessories and modifications can be found on page 34.

**Additional Warranties**  
Net Pricing

One year parts and labor contract --- \$279

Two year parts and labor contract -- \$523

Five year compressor warranty

1/5 H.P. ----- \$108  
1/3 H.P. ----- \$128  
1/2 H.P. ----- \$139

# UNDERCOUNTER ACCESSORIES

## 400 AND UC4000

### Backs

- 420040 400 One section stainless steel back -----\$530
- 420043 4000 Two section stainless steel back -----\$770

### Casters

- Four 3" (3.75" ride height) NSF certified casters (AS000-AXD-0041) \$265
- Four 5" (6.0" ride height) NSF certified casters (AS000-AXD-0042) -\$225

### Collar

- Model 409 stacking collar (adds 4" to overall combined height; for use with models 406/407) -----\$271

### Door Lock (not available on glass doors)

- 420104 Original order only; not field-installable; per door -----\$293

### Electrical

- 420021 230 volt, 50 cycle electrical system -----\$432
- AS000-B88-0032 220/60/1 Voltage package ----- \$1,273

### Fronts

- Plastic laminate front (specify color on original order)
- A130147827 27" units -----\$293
- A130147848 48" units -----\$421

### Overshelves

- Stainless steel single-tier overshelf (for field installation)
- 27" -----\$355
- 48" -----\$559

### Shelves

- AS3978273 Additional shelf (48", 72") ----- \$80
- AS3978274 Additional shelf (27")----- \$80
- AS3978275 Additional shelf (60")----- \$80
- AS3978276 Additional shelf (32", 64") ----- \$80

### Glass Doors

- (If interior light is required, it must be ordered as an option)
- 4400GLSDR24 24" -----\$698
- 4400GLSDR27 27" -----\$785
- 4400GLSDR30 30" -----\$875
- 4400GLSDR32 32" -----\$930

### Stainless steel overshelves

- Single tier
- 27" -----\$355
- 32" -----\$385
- 48" -----\$559
- 60" -----\$657
- 64" -----\$732
- 72" -----\$809
- Double tier
- 27" -----\$711
- 32" -----\$770
- 48" -----\$1,118
- 60" -----\$1,314
- 64" -----\$1,465
- 72" -----\$1,617

### Remote configuration (condensing unit by others) -----Deduct \$525

- 4400LIGHT Interior incandescent light -----\$732

## UC4400 AND UC4500 ACCESSORIES

### Backs

- Stainless steel back
- 420040 27" -----\$530
- A000-B4V-003N 32" -----\$530
- 420043 48" -----\$770
- A000-B4V-003T 60" -----\$972
- A000-B4V-003U 64" -----\$1,023
- A000-B4V-003W 72" -----\$1,119

### Cutting Board

- Composite cutting board
- 27" -----\$198
- 32" -----\$235
- 48" -----\$359
- 60" -----\$439
- 64" -----\$473
- 72" -----\$539

### Cutting Top

- Full size Polyethylene cutting top
- 44PCB27 27" -----\$293
- 44PCB32 32" -----\$391
- 44PCB48 48" -----\$543
- 44PCB60 60" -----\$644
- 44PCB64 64" -----\$643
- 44PCB72 72" -----\$710

### Electrical-(transformers shipped loose, not installed at factory)

- 420021 230 volt, 50 cycle electrical system -----\$432
- AS000-B88-0032 220/60/1 Voltage package ----- \$1,273

### Front

- Plastic laminate front (specify color on original order)
- A130147827 27" -----\$293
- A130147832 32" -----\$318
- A130147848 48" -----\$421
- A130147860 60" -----\$496
- A130147864 64" -----\$519
- A130147872 72" -----\$569

### Plastic laminate back (specify color on original order)

- A130147827B 27" -----\$293
- A130147832B 32" -----\$318
- A130147848B 48" -----\$421
- A130147860B 60" -----\$496
- A130147864B 64" -----\$519
- A130147872B 72" -----\$569

### Overshelves (18" wide standard)

- Stainless steel overshelf
- 27" -----\$355
- 32" -----\$385
- 48" -----\$559
- 60" -----\$657
- 64" -----\$732
- 72" -----\$809

### Shelves

- AS3978273 Additional shelf (48", 72") ----- \$80
- AS3978274 Additional shelf (27")----- \$80
- AS3978275 Additional shelf (60")----- \$80
- AS3978276 Additional shelf (32", 64") ----- \$80
- 4400LIGHT Interior incandescent light -----\$732
- 4400EXTERM Exterior thermometer (door models only) -----\$488

Drawer configurations for UCD4400N/UCD4500N Series only.

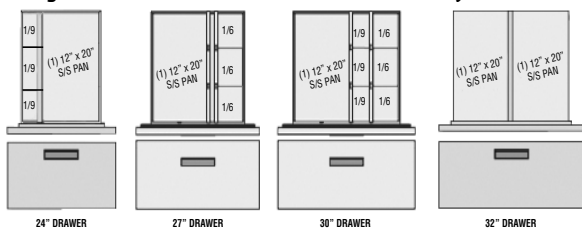



**400 Series** - Work Top Refrigerator/  
Freezer Bases

**4000 Series** - Work Top Refrigerator/  
Freezer Bases

**4400 Series** - Flat Top and Work Top  
Refrigerators

**4500 Series** - Flat Top and Work Top  
Freezers

**BUCM/BSTM** - Refrigerated Work  
Tables With and Without Backsplash

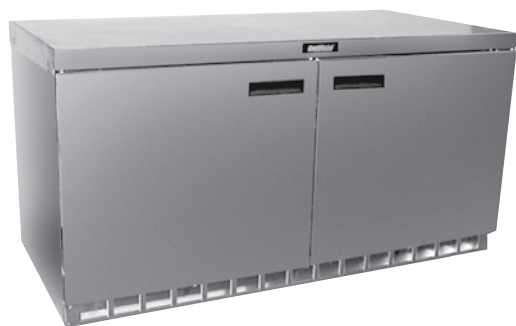

# 400 - REFRIGERATED/FREEZER WORK TABLES

## ST4000 - REFRIGERATED/FREEZER WORK TABLES



402

### Product Information

- Features Delfield's exclusive Delrite ABS interior. ABS is extremely durable - it won't dent, chip or corrode and is backed by a limited lifetime warranty
- Stainless steel front, sides and top
- Environmentally friendly R404A refrigerant
- Foamed in place polyurethane cuts energy costs
- Black recessed quick grip handle
- Rugged 6" high heavy duty metal legs
- Door hinging available on either right or left, right side is standard
- 60-cycle single phase electrical system
- 6' cord and plug supplied
- One year parts and 90 day labor standard warranty. Additional warranties available, see below

### 400 Series Only

- Two epoxy coated wire shelves, standard installed per unit

### ST4000 Series Only

- 4" backsplash has two knockouts with covers for electrical outlets (outlets provided by others)
- Four epoxy coated wire shelves standard per unit

### Specifications and Prices

MODEL NUMBER	DESCRIPTION	OVERALL			STOR. CU. FT.	H.P.	AMP	VOLTS	NEMA PLUG	SHIP WEIGHT	FREIGHT CLASS	LIST PRICE
		L	D	H								
<b>WORK TOP REFRIGERATOR BASES</b> with stainless steel top & backsplash												
402	1 door	27"	28.5"	39.5"	5.7	1/5	4.0	115	5-15P	176	110	<b>\$3,875</b>
<b>WORK TOP FREEZER BASES</b> with stainless steel top & backsplash												
403	1 door	27"	28.5"	39.5"	5.7	1/5	5.8	115	5-15P	184	110	<b>\$4,544</b>

MODEL NUMBER	OVERALL	OVERALL		STOR. CU. FT.	H.P.	AMP	VOLTS	NEMA PLUG	SHIP WEIGHT	FREIGHT CLASS	LIST PRICE
	L	D	H								
<b>48" WORK TOP REFRIGERATOR BASES</b> with stainless steel top & backsplash											
ST4048	48"	28.5"	39.5"	11.4	1/5	4.0	115	5-15P	234	110	<b>\$5,770</b>
<b>48" WORK TOP FREEZER BASES</b> with stainless steel top & backsplash											
ST4148	48"	28.5"	39.5"	11.4	1/3	5.8	115	5-15P	242	110	<b>\$6,399</b>

400 and 4000 accessories and modifications can be found on page 39.

#### Additional Warranties

Net Pricing

One year parts and labor contract ---\$279

Two year parts and labor contract --\$523

Five year compressor warranty  
1/5 H.P. -----\$108





# 4400N - REFRIGERATED WORK TABLES 4500N - FREEZER WORK TABLES

## Product Information

- All 4400 and 4500 Series units are 100% front breathing, which allows the unit to be pushed against a wall or built into a cabinet or an existing line up
- Durable, rugged stainless steel sides, top and front
- Features Delfield's exclusive Delrite ABS interior (on sides). ABS is extremely durable - it won't dent, chip or corrode and is backed by a limited lifetime warranty
- Heavy duty self-closing hinges
- "ST" prefix models have a 4" stainless steel backsplash
- "D" prefix models feature Delfield's exclusive new drawer system. Drawers are backed by a 10-year warranty on the track assembly
- Environmentally friendly R404A refrigerant
- High density foamed in place polyurethane keeps energy costs low
- Black recessed quick grip handle
- Standard on 5" casters for easy cleaning and installation
- 60-cycle single phase electrical system
- 6' cord and plug supplied
- One epoxy coated wire shelf standard, installed per door section
- One year parts and 90 day labor standard warranty. Additional warranties available, see below



4464N

## Specifications and Prices

MODEL NUMBER	DESCRIPTION	Work Height*			VOL. CU. FT.	H.P.	AMP	VOLTS	NEMA PLUG	SHIP WEIGHT	FREIGHT CLASS	LIST PRICE
		L	D	H								
<b>27" REFRIGERATED FLAT TOP AND WORK TOP</b>												
4427N	one door	27"	31.5"	36"	5.7	1/5	3.9	115	5-15P	223	110	\$4,281
D4427N	two drawers	27"	31.5"	36"	5.7	1/5	3.9	115	5-15P	245	110	\$5,908
ST4427N	one door	27"	31.5"	36"	5.7	1/5	3.9	115	5-15P	223	110	\$4,496
STD4427N	two drawers	27"	31.5"	36"	5.7	1/5	3.9	115	5-15P	245	110	\$6,128
<b>32" REFRIGERATED FLAT TOP AND WORK TOP</b>												
4432N	one door	32"	31.5"	36"	6.9	1/5	3.9	115	5-15P	245	110	\$5,250
D4432N	two drawers	32"	31.5"	36"	6.9	1/5	3.9	115	5-15P	293	110	\$6,827
ST4432N	one door	32"	31.5"	36"	6.9	1/5	3.9	115	5-15P	245	110	\$5,486
STD4432N	two drawers	32"	31.5"	36"	6.9	1/5	3.9	115	5-15P	293	110	\$7,071
<b>48" REFRIGERATED FLAT TOP AND WORK TOP</b>												
4448N	two doors	48"	31.5"	36"	10.7	1/5	3.9	115	5-15P	316	110	\$5,586
D4448N	four drawers	48"	31.5"	36"	10.7	1/5	3.9	115	5-15P	398	110	\$8,700
ST4448N	two doors	48"	31.5"	36"	10.7	1/5	3.9	115	5-15P	316	110	\$5,864
STD4448N	four drawers	48"	31.5"	36"	10.7	1/5	3.9	115	5-15P	398	110	\$9,067
<b>60" REFRIGERATED FLAT TOP AND WORK TOP</b>												
4460N	two doors	60"	31.5"	36"	15.7	1/5	3.9	115	5-15P	411	110	\$6,606
D4460N	four drawers	60"	31.5"	36"	15.7	1/5	3.9	115	5-15P	495	110	\$9,700
ST4460N	two doors	60"	31.5"	36"	15.7	1/5	3.9	115	5-15P	411	110	\$6,928
STD4460N	four drawers	60"	31.5"	36"	15.7	1/5	3.9	115	5-15P	495	110	\$10,027
<b>64" REFRIGERATED FLAT TOP AND WORK TOP</b>												
4464N	two doors	64"	31.5"	36"	16.7	1/5	3.9	115	5-15P	421	110	\$7,260
D4464N	four drawers	64"	31.5"	36"	16.7	1/5	3.9	115	5-15P	522	110	\$10,285
ST4464N	two doors	64"	31.5"	36"	16.7	1/5	3.9	115	5-15P	421	110	\$7,527
STD4464N	four drawers	64"	31.5"	36"	16.7	1/5	3.9	115	5-15P	522	110	\$10,630
<b>72" REFRIGERATED FLAT TOP AND WORK TOP</b>												
4472N	three doors	72"	31.5"	36"	18.7	1/5	3.9	115	5-15P	461	110	\$7,752
D4472N	six drawers	72"	31.5"	36"	18.7	1/5	3.9	115	5-15P	545	110	\$11,763
ST4472N	three doors	72"	31.5"	36"	18.7	1/5	3.9	115	5-15P	461	110	\$8,125
STD4472N	six drawers	72"	31.5"	36"	18.7	1/5	3.9	115	5-15P	545	110	\$11,915
<b>32" FREEZER FLAT TOP AND WORK TOP</b>												
4532N	one door	32"	31.5"	36"	6.9	1/3	9.5	115	5-15P	245	110	\$6,002
D4532N	two drawers	32"	31.5"	36"	6.9	1/3+	12.0	115	5-15P	293	110	\$7,528
ST4532N	one door	32"	31.5"	36"	6.9	1/3	9.5	115	5-15P	245	110	\$6,179
STD4532N	two drawers	32"	31.5"	36"	6.9	1/3+	12.0	115	5-15P	293	110	\$7,969
<b>60" FREEZER FLAT TOP AND WORK TOP</b>												
4560N	two doors	60"	31.5"	36"	16.9	1/3	12.0	115	5-15P	411	110	\$8,122
ST4560N	two doors	60"	31.5"	36"	16.9	1/3	12.0	115	5-15P	411	110	\$8,372

\* ST models are 40" overall height

4400 and 4500 accessories and modifications can be found on page 39.

Additional Warranties	
Net Pricing	
One year parts and labor contract ---	\$279
Two year parts and labor contract --	\$523
Five year compressor warranty	
1/5 H.P. -----	\$108
1/3 H.P. -----	\$128
1/2 H.P. -----	\$139

Effective August 2011. All prices F.O.B. Covington, Tennessee 38019. Prices may vary on accessories ordered from the Parts Department. Visit [www.delfield.com](http://www.delfield.com) for specification sheets.



REFRIGERATED AND FREEZER WORK TABLES

**18600BUKM - REFRIGERATED WORK TABLES****18600BSTM - REFRIGERATED WORK TABLES WITH BACKSPLASH****18648BUKM****Product Information**

- Stainless steel exterior is standard. Optional laminate facing is available
- Compressor is located on right
- Finished stainless steel ends
- 18-gauge stainless steel top
- BSTM models indicate a 4" high backsplash
- Environmentally friendly HFC-404A refrigerant
- Standard on casters
- One year parts 90 days labor standard warranty. Additional warranties available, see below

**Specifications and Prices**

MODEL NUMBER	# OF DOORS	OVERALL			STOR CU. FT.	H.P.	AMP	VOLTS	NEMA PLUG	SHIP WEIGHT	FREIGHT CLASS	LIST PRICE
		L	D	H								

**REFRIGERATED WORK TABLES**

Remote units available — See accessory pricing.

**Self-Contained**

<b>18648BUKM</b>	(1) 27"	48"	31.5"	36"	10.23	1/5	8.0	115	5-15P	390	110	<b>\$7,225</b>
<b>18660BUKM</b>	19" & 27"	60"	31.5"	36"	15.12	1/5	8.0	115	5-15P	435	110	<b>\$8,429</b>
<b>18672BUKM</b>	(2) 27"	72"	31.5"	36"	18.10	1/4	10.0	115	5-15P	495	110	<b>\$9,690</b>
<b>18691BUKM</b>	(2) 27" & 19"	91"	31.5"	36"	24.48	1/4	10.0	115	5-15P	535	110	<b>\$12,239</b>
<b>18699BUKM</b>	(3) 27"	99"	31.5"	36"	27.46	1/3	12.0	115	5-15P	594	110	<b>\$12,837</b>
<b>186114BUKM</b>	(3) 32"	114"	31.5"	36"	37.24	1/3	12.0	115	5-15P	685	110	<b>\$14,789</b>

MODEL NUMBER	# OF DOORS	OVERALL			STOR CU. FT.	H.P.	AMP	VOLTS	NEMA PLUG	SHIP WEIGHT	FREIGHT CLASS	LIST PRICE
		L	D	H								

**REFRIGERATED WORK TABLES WITH BACKSPLASH**

Remote units available — See accessory pricing.

**Self-Contained**

<b>18648BSTM</b>	(1) 27"	48"	31.5"	40"	10.23	1/5	8.0	115	5-15P	390	110	<b>\$7,513</b>
<b>18660BSTM</b>	19" & 27"	60"	31.5"	40"	15.12	1/5	8.0	115	5-15P	435	110	<b>\$8,658</b>
<b>18672BSTM</b>	(2) 27"	72"	31.5"	40"	18.10	1/4	10.0	115	5-15P	495	110	<b>\$10,070</b>
<b>18691BSTM</b>	(2) 27" & 19"	91"	31.5"	40"	24.48	1/4	10.0	115	5-15P	535	110	<b>\$12,718</b>
<b>18699BSTM</b>	(3) 27"	99"	31.5"	40"	27.46	1/4	10.0	115	5-15P	594	110	<b>\$13,360</b>
<b>186114BSTM</b>	(3) 32"	114"	31.5"	40"	37.24	1/3	12.0	115	5-15P	685	110	<b>\$15,387</b>

18600BUKM AND 18600BSTM accessories and modifications can be found on page 39.

**Additional Warranties**

Net Pricing

One year parts and labor contract ---\$279

Two year parts and labor contract --\$523

Five year compressor warranty

1/5 H.P. -----\$108

1/4 H.P. -----\$108

1/3 H.P. -----\$128



## 400/4000/4400N/4500N SERIES

<b>Casters (only for 400/4000 series units)</b>	
Four 3" (3.75" ride height) NSF certified casters (AS000-AXD-0041) -----	\$265
<b>420104</b> Door lock original order only; (not available on glass doors) not field-installable; 1 section-----	\$293
<b>420102</b> Door lock original order only; (not available on glass doors) not field-installable; 2&3 section-----	\$586
<b>Shelves</b>	
<b>AS3978273</b> Additional shelf (48", 72") -----	\$80
<b>AS3978274</b> Additional shelf (27")-----	\$80
<b>AS3978275</b> Additional shelf (60")-----	\$80
<b>AS3978276</b> Additional shelf (32", 64") -----	\$80
<b>Electrical-(transformers shipped loose, not installed at factory)</b>	
<b>420021</b> 230 volt, 50 cycle electrical system -----	\$432
<b>AS000-B88-0032</b> 220/60/1 Voltage package-----	\$1,273
<b>4400EXTHERM</b> Exterior thermometer (44/4500 door models only) -	\$488
<b>Stainless steel overshelves</b>	
Single tier 27" -----	\$355
32" -----	\$385
48" -----	\$559
60" -----	\$657
64" -----	\$732
72" -----	\$809
Double tier 27" -----	\$711
32" -----	\$770
48" -----	\$1,118
60" -----	\$1,314
64" -----	\$1,465
72" -----	\$1,617
Non-standard pan cutout locations -----	Add \$558
(see accessory sheet for possible locations)	
Plastic laminate front (specify color on original order)	
<b>A130147827</b> 27" -----	\$293
<b>A130147832</b> 32" -----	\$318
<b>A130147848</b> 48" -----	\$421
<b>A130147860</b> 60" -----	\$496
<b>A130147864</b> 64" -----	\$519
<b>A130147872</b> 72" -----	\$569
Plastic laminate back (specify color on original order)	
<b>A130147827B</b> 27" -----	\$293
<b>A130147832B</b> 32" -----	\$318
<b>A130147848B</b> 48" -----	\$421
<b>A130147860B</b> 60" -----	\$496
<b>A130147864B</b> 64" -----	\$519
<b>A130147872B</b> 72" -----	\$569
<b>Stainless steel back</b>	
<b>0420040</b> 27" -----	\$530
<b>A000-B4V-003N</b> 32" -----	\$530
<b>0420043</b> 48" -----	\$770
<b>A000-B4V-003T</b> 60" -----	\$972
<b>A000-B4V-003U</b> 64" -----	\$1,023
<b>A000-B4V-003W</b> 72" -----	\$1,119
<b>4400LIGHT</b> Interior incandescent light -----	\$732

## BUCM & BSTM MODELS

Stainless steel back (per linear foot) -----	\$255
Laminate facing for BUCM & BSTM units; per linear foot-----	\$122
(Laminate facing for rear of BUCM & BSTM units requires stainless steel back)	
Cutting board (20" wide x 1/2" thick) (BUCM & BSTM)	
48" -----	\$910
60" -----	\$1,066
72" -----	\$1,288
91" -----	\$1,572
99" -----	\$1,823
114" -----	\$2,092
18" wide single tier overshelf (BUCM & BSTM)	
48" -----	\$867
60" -----	\$1,086
72" -----	\$1,304
91" -----	\$1,651
99" -----	\$1,797
114" -----	\$2,075
<b>Electrical-(transformers shipped loose, not installed at factory)</b>	
230 volt, 50 cycle electrical system -----	\$1,180
220/60/1 Voltage package -----	\$1,180
Drawers 19", 3 high, hold one 12" x 20" x 4" deep pan per drawer (BUCM & BSTM) -----	\$3,206
Drawers 19", 2 high, hold one 12" x 20" x 6" deep pan per drawer (BUCM & BSTM) -----	\$2,484
Drawers 27", 2 high, hold two 12" x 20" x 6" deep pans per drawer -----	\$3,335
Drawers 27", 3 high, hold two 12" x 20" x 4" deep pans per drawer -----	\$2,625
Drawers 32", 2 high, hold two 12" x 20" x 6" deep pans per drawer -----	\$3,335
Drawers 32", 3 high, hold two 12" x 20" x 4" deep pans per drawer -----	\$2,625
Remote refrigeration (BUCM & BSTM)	
Overall unit length remains the same.	
Delete 1/4, 1/3 and 1/2 horsepower system -----	CREDIT \$618
Delete 3/4 horsepower system -----	CREDIT \$751
TR9B tray rack (base support style for 18" x 26" trays; 2" centers) (BUCM & BSTM) -----	\$316

Drawer configurations for 4000N/4400N/4500N series only.

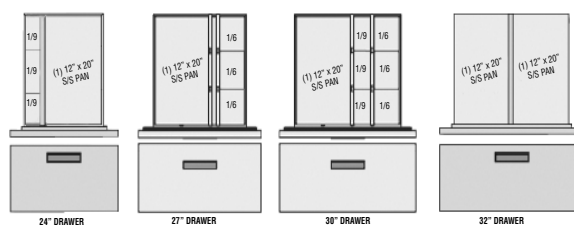

Drawer configurations for BUCM and BSTM series.

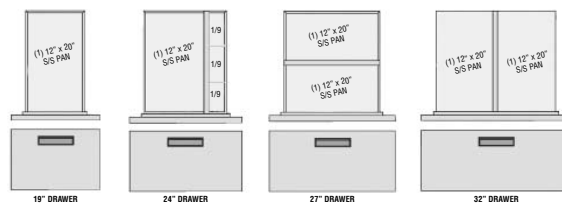



**4400N Series** - Salad Top Compact  
Prep Tables

**18000PTBM** - Standard Pizza  
Prep Tables

**18600PTL** - LiquiTec® Pizza Prep Tables

**18600PDL** - Dual Rail Pizza Prep Tables

**CTP-NB** - Counter Top Prep Rails

VOTED BEST  
IN CLASS  
PREP  
TABLES

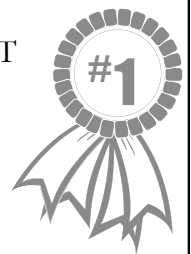

Prep Tables

# 4400N - SALAD TOP PREP TABLES

## Product Information

- Patented air screen ensures product stays cold without drying it out
- All 4400 Series units are 100% front breathing, which allows the unit to be pushed against a wall or built into a cabinet or an existing line up
- Durable, rugged stainless steel sides, top and front
- Features Delfield's exclusive Delrite ABS interior (on sides). ABS is extremely durable - it won't dent, chip or corrode and is backed by a limited lifetime warranty
- Delfield supplies 1/6 size pans and adapter bars for top opening
- Salad top refrigerators are standard with 10" wide, dishwasher safe polyethylene cutting board with antimicrobial treatment
- "D" prefix models feature Delfield's new drawer system. Drawers are backed by a 10-year warranty on the track assembly
- Environmentally friendly R404A refrigerant
- High density foamed in place polyurethane keeps energy costs low
- Black recessed quick grip handle
- Standard on 5" casters for easy cleaning and installation
- 6' cord and plug supplied
- One epoxy coated wire shelf standard, installed per door section
- "ST" prefix models have a 4" stainless steel backsplash
- ACT solid state electronic control
- One year parts and 90 day labor standard warranty. Additional warranties available, see below



**4427N-6**  
Shown with optional hinged cover



**4464N-16**

PREP TABLES

## Specifications and Prices

MODEL NUMBER	DESCRIPTION	OVERALL L	OVERALL D	OVERALL H	VOL. CU. FT.	1/6 PAN CAP.	H.P.	AMP	VOLTS	NEMA PLUG	SHIP WEIGHT	FREIGHT CLASS	LIST PRICE
<b>27" SALAD TOP REFRIGERATOR BASES</b>													
4427N-6	one door	27"	31.5"	36"	5.7	6	1/5	7.2	115	5-15P	223	110	\$4,340
D4427N-6	two drawers	27"	31.5"	36"	5.7	6	1/5	7.2	115	5-15P	245	110	\$5,912
<b>48" SALAD TOP REFRIGERATOR BASES</b>													
4448N-8	two doors	48"	31.5"	36"	10.7	8	1/5	7.2	115	5-15P	316	110	\$5,840
D4448N-8	four drawers	48"	31.5"	36"	10.7	8	1/5	7.2	115	5-15P	398	110	\$8,927
4448N-12	two doors	48"	31.5"	36"	10.7	12	1/5	7.2	115	5-15P	316	110	\$6,312
D4448N-12	four drawers	48"	31.5"	36"	10.7	12	1/5	7.2	115	5-15P	398	110	\$9,422
ST4448N-8	two doors	48"	31.5"	36"	10.7	8	1/5	7.2	115	5-15P	316	110	\$6,186
STD4448N-8	four drawers	48"	31.5"	36"	10.7	8	1/5	7.2	115	5-15P	398	110	\$9,206
<b>60" SALAD TOP REFRIGERATOR BASES</b>													
4460N-8	two doors	60"	31.5"	36"	15.7	8	1/2	12.0	115	5-15P	411	110	\$7,312
D4460N-8	four drawers	60"	31.5"	36"	15.7	8	1/2	12.0	115	5-15P	495	110	\$10,411
4460N-12	two doors	60"	31.5"	36"	15.7	12	1/2	12.0	115	5-15P	411	110	\$7,650
D4460N-12	four drawers	60"	31.5"	36"	15.7	12	1/2	12.0	115	5-15P	495	110	\$10,755
ST4460N-8	two doors	60"	31.5"	36"	15.7	8	1/2	12.0	115	5-15P	411	110	\$7,637
STD4460N-8	four drawers	60"	31.5"	36"	15.7	8	1/2	12.0	115	5-15P	495	110	\$10,739
<b>64" SALAD TOP REFRIGERATOR BASES</b>													
4464N-8	two doors	64"	31.5"	36"	16.7	8	1/2	12.0	115	5-15P	421	110	\$7,661
D4464N-8	four drawers	64"	31.5"	36"	16.7	8	1/2	12.0	115	5-15P	522	110	\$10,771
4464N-12	two doors	64"	31.5"	36"	16.7	12	1/2	12.0	115	5-15P	421	110	\$8,083
D4464N-12	four drawers	64"	31.5"	36"	16.7	12	1/2	12.0	115	5-15P	522	110	\$11,194
4464N-16	two doors	64"	31.5"	36"	16.7	16	1/2	12.0	115	5-15P	421	110	\$8,518
D4464N-16	four drawers	64"	31.5"	36"	16.7	16	1/2	12.0	115	5-15P	522	110	\$11,630
ST4464N-8	two doors	64"	31.5"	36"	16.7	8	1/2	12.0	115	5-15P	421	110	\$7,925
STD4464N-8	four drawers	64"	31.5"	36"	16.7	8	1/2	12.0	115	5-15P	522	110	\$11,041
ST4464N-12	two doors	64"	31.5"	36"	16.7	12	1/2	12.0	115	5-15P	421	110	\$8,351
STD4464N-12	four drawers	64"	31.5"	36"	16.7	12	1/2	12.0	115	5-15P	522	110	\$11,463
<b>72" SALAD TOP REFRIGERATOR BASES</b>													
4472N-12	three doors	72"	31.5"	36"	18.7	12	1/2	12.0	115	5-15P	461	110	\$8,735
D4472N-12	six drawers	72"	31.5"	36"	18.7	12	1/2	12.0	115	5-15P	545	110	\$12,773
4472N-18	three doors	72"	31.5"	36"	18.7	18	1/2	12.0	115	5-15P	461	110	\$8,928
D4472N-18	six drawers	72"	31.5"	36"	18.7	18	1/2	12.0	115	5-15P	545	110	\$12,974
ST4472N-12	three doors	72"	31.5"	36"	18.7	12	1/2	12.0	115	5-15P	461	110	\$9,109
STD4472N-12	six drawers	72"	31.5"	36"	18.7	12	1/2	12.0	115	5-15P	545	110	\$13,157

4400N Series accessories and modifications can be found on page 46.

**10-year Warranty on Delfield's Drawer System Track!**

### Additional Warranties

Net Pricing  
One year parts and labor contract --- \$279

Two year parts and labor contract -- \$523

Five year compressor warranty  
1/5 H.P. ----- \$108  
1/2 H.P. ----- \$139



# 4400NM - MEGA TOP PREP TABLES

## Product Information

- Patented air screen design ensures product stays cold without drying it out
- All 4400 Series units are 100% front breathing, which allows the unit to be pushed against a wall or built into a cabinet or an existing line up
- Durable, rugged stainless steel sides, top and front
- Features Delfield's exclusive Delrite ABS interior (on sides). ABS is extremely durable - it won't dent, chip or corrode and is backed by a limited lifetime warranty
- Delfield supplies 1/6 size plastic pans and adapter bars for top opening
- Heavy duty self-closing hinges
- Mega top refrigerators are standard with 8" wide, dishwasher safe polyethylene cutting board with antimicrobial treatment
- "D" prefix models feature Delfield's exclusive new drawer system. Drawers are backed by a 10-year warranty on the track assembly (Great for fast replenishment!)
- Environmentally friendly R404A refrigerant
- High density foamed in place polyurethane keeps energy costs low
- Black recessed quick grip handle
- Standard on 5" casters for easy cleaning and installation
- 60-cycle single phase electrical system
- 6' cord and plug supplied
- One epoxy coated wire shelf standard, installed per door section
- "ST" prefix models have a 4" stainless steel backsplash
- ACT solid state electronic control
- One year parts and 90 day labor standard warranty. Additional warranties available.



4432N-12M



4464N-24M

**10-year Warranty on Delfield's Drawer System Track!**

## Specifications and Prices

MODEL NUMBER	DESCRIPTION	OVERALL L	OVERALL D	OVERALL H	VOL. CU. FT.	1/6 PAN CAP.	H.P.	AMP	VOLTS	NEMA PLUG	SHIP WEIGHT	FREIGHT CLASS	LIST PRICE
<b>27" MEGA TOP FRONT BREATHERS</b>													
4427N-9M	one door	27"	31.5"	36"	5.7	9	1/5	7.2	115	5-15P	223	110	\$5,053
D4427N-9M	two drawers	27"	31.5"	36"	5.7	9	1/5	7.2	115	5-15P	245	110	\$6,630
4427N-12M	one door	27"	31.5"	36"	5.7	12	1/5	7.2	115	5-15P	223	110	\$5,171
D4427N-12M	two drawers	27"	31.5"	36"	5.7	12	1/5	7.2	115	5-15P	245	110	\$6,720
ST4427N-12M	one door	27"	31.5"	36"	5.7	12	1/5	7.2	115	5-15P	223	110	\$5,446
STD4427N-12M	two drawers	27"	31.5"	36"	5.7	12	1/5	7.2	115	5-15P	245	110	\$6,998
<b>32" MEGA TOP FRONT BREATHERS</b>													
4432N-12M	one door	32"	31.5"	36"	6.9	12	1/5	7.2	115	5-15P	245	110	\$6,368
D4432N-12M	two drawers	32"	31.5"	36"	6.9	12	1/5	7.2	115	5-15P	293	110	\$7,961
<b>48" MEGA TOP FRONT BREATHERS</b>													
4448N-18M	two doors	48"	31.5"	36"	10.7	18	1/5	7.2	115	5-15P	316	110	\$7,762
D4448N-18M	four drawers	48"	31.5"	36"	10.7	18	1/5	7.2	115	5-15P	398	110	\$10,867
<b>60" MEGA TOP FRONT BREATHERS</b>													
4460N-12M	two doors	60"	31.5"	36"	15.7	12	1/2	12.0	115	5-15P	411	110	\$8,105
D4460N-12M	four drawers	60"	31.5"	36"	15.7	12	1/2	12.0	115	5-15P	495	110	\$11,215
4460N-18M	two doors	60"	31.5"	36"	15.7	18	1/2	12.0	115	5-15P	411	110	\$8,311
D4460N-18M	four drawers	60"	31.5"	36"	15.7	18	1/2	12.0	115	5-15P	495	110	\$11,423
4460N-24M	two doors	60"	31.5"	36"	15.7	24	1/2	12.0	115	5-15P	411	110	\$8,507
D4460N-24M	four drawers	60"	31.5"	36"	15.7	24	1/2	12.0	115	5-15P	495	110	\$11,619
ST4460N-12M	two doors	60"	31.5"	36"	15.7	12	1/2	12.0	115	5-15P	411	110	\$8,428
STD4460N-12M	four drawers	60"	31.5"	36"	15.7	12	1/2	12.0	115	5-15P	495	110	\$11,542
ST4460N-18M	two doors	60"	31.5"	36"	15.7	18	1/2	12.0	115	5-15P	411	110	\$8,636
STD4460N-18M	four drawers	60"	31.5"	36"	15.7	18	1/2	12.0	115	5-15P	495	110	\$11,748
<b>64" MEGA TOP FRONT BREATHER</b>													
4464N-12M	two doors	64"	31.5"	36"	16.7	12	1/2	12.0	115	5-15P	421	110	\$8,694
D4464N-12M	four drawers	64"	31.5"	36"	16.7	12	1/2	12.0	115	5-15P	522	110	\$11,817
4464N-18M	two doors	64"	31.5"	36"	16.7	18	1/2	12.0	115	5-15P	421	110	\$8,910
D4464N-18M	four drawers	64"	31.5"	36"	16.7	18	1/2	12.0	115	5-15P	522	110	\$12,027
4464N-24M	two doors	64"	31.5"	36"	16.7	24	1/2	12.0	115	5-15P	421	110	\$9,107
D4464N-24M	four drawers	64"	31.5"	36"	16.7	24	1/2	12.0	115	5-15P	522	110	\$12,222
ST4464N-12M	two doors	64"	31.5"	36"	16.7	12	1/2	12.0	115	5-15P	421	110	\$8,961
STD4464N-12M	four drawers	64"	31.5"	36"	16.7	12	1/2	12.0	115	5-15P	522	110	\$12,086
ST4464N-18M	two doors	64"	31.5"	36"	16.7	18	1/2	12.0	115	5-15P	421	110	\$9,177
STD4464N-18M	four drawers	64"	31.5"	36"	16.7	18	1/2	12.0	115	5-15P	522	110	\$12,295
<b>72" MEGA TOP FRONT BREATHER</b>													
4472N-18M	three doors	72"	31.5"	36"	18.7	18	1/2	12.0	115	5-15P	461	110	\$9,320
D4472N-18M	six drawers	72"	31.5"	36"	18.7	18	1/2	12.0	115	5-15P	545	110	\$13,384
4472N-24M	three doors	72"	31.5"	36"	18.7	24	1/2	12.0	115	5-15P	461	110	\$9,517
D4472N-24M	six drawers	72"	31.5"	36"	18.7	24	1/2	12.0	115	5-15P	545	110	\$13,578
4472N-30M	three doors	72"	31.5"	36"	18.7	30	1/2	12.0	115	5-15P	461	110	\$9,714
D4472N-30M	six drawers	72"	31.5"	36"	18.7	30	1/2	12.0	115	5-15P	545	110	\$13,782
ST4472N-18M	three doors	72"	31.5"	36"	18.7	18	1/2	12.0	115	5-15P	461	110	\$9,694
STD4472N-18M	six drawers	72"	31.5"	36"	18.7	18	1/2	12.0	115	5-15P	545	110	\$13,765
ST4472N-24M	three doors	72"	31.5"	36"	18.7	24	1/2	12.0	115	5-15P	461	110	\$9,890
STD4472N-24M	six drawers	72"	31.5"	36"	18.7	24	1/2	12.0	115	5-15P	545	110	\$13,961

4400N Series accessories and modifications can be found on page 46.

### Additional Warranties

Net Pricing

One year parts and labor contract ---\$279

Two year parts and labor contract --\$523

Five year compressor warranty  
1/5 H.P. -----\$108  
1/2 H.P. -----\$139



Effective August 2011. All prices F.O.B. Covington, Tennessee 38019. Prices may vary on accessories ordered from the Parts Department. Visit [www.delfield.com](http://www.delfield.com) for specification sheets.



# UC4400N - REDUCED WORK HEIGHT SALAD TOP PREP TABLES

## Product Information

- Patented air screen ensures product stays cold without drying it out
- All 4400 Series units are 100% front breathing, which allows the unit to be pushed against a wall or built into a cabinet or an existing line up
- Durable, rugged stainless steel sides, top and front
- Features Delfield's exclusive Delrite ABS interior (on sides). ABS is extremely durable - it won't dent, chip or corrode and is backed by a limited lifetime warranty
- Delfield supplies 1/6 size pans and adapter bars for top opening
- Salad top refrigerators are standard with 10" wide, dishwasher safe polyethylene cutting board with antimicrobial treatment
- "D" prefix models feature Delfield's new drawer system. Drawers are backed by a 10-year warranty on the track assembly
- Environmentally friendly R404A refrigerant
- High density foamed in place polyurethane keeps energy costs low
- Black recessed quick grip handle
- Standard on 3" casters for easy cleaning and installation
- 6' cord and plug supplied
- One epoxy coated wire shelf standard, installed per door section
- ACT solid state electronic control
- One year parts and 90 day labor standard warranty. Additional warranties available, see below



**UC4427N-6**  
Shown with optional hinged cover



**UC4464N-16**

## Specifications and Prices

MODEL NUMBER	DESCRIPTION	L	OVERALL D	H	VOL. CU. FT.	1/6 PAN CAP.	H.P.	AMP	VOLTS	NEMA PLUG	SHIP WEIGHT	FREIGHT CLASS	LIST PRICE
<b>27" SALAD TOP REFRIGERATOR BASES</b>													
UC4427N-6	one door	27"	31.5"	34.25"	5.7	6	1/5	7.2	115	5-15P	223	110	\$4,340
UCD4427N-6	two drawers	27"	31.5"	34.25"	5.7	6	1/5	7.2	115	5-15P	245	110	\$5,912
<b>48" SALAD TOP REFRIGERATOR BASES</b>													
UC4448N-8	two doors	48"	31.5"	34.25"	10.7	8	1/5	7.2	115	5-15P	316	110	\$5,840
UCD4448N-8	four drawers	48"	31.5"	34.25"	10.7	8	1/5	7.2	115	5-15P	398	110	\$8,927
UC4448N-12	two doors	48"	31.5"	34.25"	10.7	12	1/5	7.2	115	5-15P	316	110	\$6,312
UCD4448N-12	four drawers	48"	31.5"	34.25"	10.7	12	1/5	7.2	115	5-15P	398	110	\$9,422
<b>60" SALAD TOP REFRIGERATOR BASES</b>													
UC4460N-8	two doors	60"	31.5"	34.25"	15.7	8	1/2	12.0	115	5-15P	411	110	\$7,312
UCD4460N-8	four drawers	60"	31.5"	34.25"	15.7	8	1/2	12.0	115	5-15P	495	110	\$10,411
UC4460N-12	two doors	60"	31.5"	34.25"	15.7	12	1/2	12.0	115	5-15P	411	110	\$7,650
UCD4460N-12	four drawers	60"	31.5"	34.25"	15.7	12	1/2	12.0	115	5-15P	495	110	\$10,755
<b>64" SALAD TOP REFRIGERATOR BASES</b>													
UC4464N-8	two doors	64"	31.5"	34.25"	16.7	8	1/2	12.0	115	5-15P	421	110	\$7,661
UCD4464N-8	four drawers	64"	31.5"	34.25"	16.7	8	1/2	12.0	115	5-15P	522	110	\$10,771
UC4464N-12	two doors	64"	31.5"	34.25"	16.7	12	1/2	12.0	115	5-15P	421	110	\$8,083
UCD4464N-12	four drawers	64"	31.5"	34.25"	16.7	12	1/2	12.0	115	5-15P	522	110	\$11,194
UC4464N-16	two doors	64"	31.5"	34.25"	16.7	16	1/2	12.0	115	5-15P	421	110	\$8,518
UCD4464N-16	four drawers	64"	31.5"	34.25"	16.7	16	1/2	12.0	115	5-15P	522	110	\$11,630
<b>72" SALAD TOP REFRIGERATOR BASES</b>													
UC4472N-12	three doors	72"	31.5"	34.25"	18.7	12	1/2	12.0	115	5-15P	461	110	\$8,735
UCD4472N-12	six drawers	72"	31.5"	34.25"	18.7	12	1/2	12.0	115	5-15P	545	110	\$12,773
UC4472N-18	three doors	72"	31.5"	34.25"	18.7	18	1/2	12.0	115	5-15P	461	110	\$8,928
UCD4472N-18	six drawers	72"	31.5"	34.25"	18.7	18	1/2	12.0	115	5-15P	545	110	\$12,974

UC4400N Series accessories and modifications can be found on page 46.

**10-year Warranty on Delfield's Drawer System Track!**

**Additional Warranties**  
Net Pricing

One year parts and labor contract --- \$279

Two year parts and labor contract -- \$523

Five year compressor warranty

1/5 H.P. ----- \$108

1/2 H.P. ----- \$139



# UC4400NM - REDUCED WORK HEIGHT MEGA TOP PREP TABLES

PREP TABLES

## Product Information

- Patented air screen design ensures product stays cold without drying it out
- All 4400 Series units are 100% front breathing, which allows the unit to be pushed against a wall or built into a cabinet or an existing line up
- Durable, rugged stainless steel sides, top and front
- Features Delfield's exclusive Delrite ABS interior (on sides). ABS is extremely durable - it won't dent, chip or corrode and is backed by a limited lifetime warranty
- Delfield supplies 1/6 size plastic pans and adapter bars for top opening
- Heavy duty self-closing hinges
- Mega top refrigerators are standard with 8" wide, dishwasher safe polyethylene cutting board with antimicrobial treatment
- "D" prefix models feature Delfield's exclusive new drawer system. Drawers are backed by a 10-year warranty on the track assembly (Great for fast replenishment!)
- Environmentally friendly R404A refrigerant
- High density foamed in place polyurethane keeps energy costs low
- Black recessed quick grip handle
- Standard on 3" casters for easy cleaning and installation
- 60-cycle single phase electrical system
- 6' cord and plug supplied
- One epoxy coated wire shelf standard, installed per door section
- ACT solid state electronic control
- One year parts and 90 day labor standard warranty. Additional warranties available.



UC4432N-12M



UC4464N-24M

**10-year Warranty on Delfield's Drawer System Track!**

## Specifications and Prices

MODEL NUMBER	DESCRIPTION	L	OVERALL D	H	VOL. CU. FT.	1/6 PAN CAP.	H.P.	AMP	VOLTS	NEMA PLUG	SHIP WEIGHT	FREIGHT CLASS	LIST PRICE
<b>27" MEGA TOP FRONT BREATHERS</b>													
UC4427N-9M	one door	27"	31.5"	34.25"	5.7	9	1/5	7.2	115	5-15P	223	110	\$5,053
UCD4427N-9M	two drawers	27"	31.5"	34.25"	5.7	9	1/5	7.2	115	5-15P	245	110	\$6,630
UC4427N-12M	one door	27"	31.5"	34.25"	5.7	12	1/5	7.2	115	5-15P	223	110	\$5,171
UCD4427N-12M	two drawers	27"	31.5"	34.25"	5.7	12	1/5	7.2	115	5-15P	245	110	\$6,720
<b>32" MEGA TOP FRONT BREATHERS</b>													
UC4432N-12M	one door	32"	31.5"	34.25"	6.9	12	1/5	7.2	115	5-15P	245	110	\$6,368
UCD4432N-12M	two drawers	32"	31.5"	34.25"	6.9	12	1/5	7.2	115	5-15P	293	110	\$7,961
<b>48" MEGA TOP FRONT BREATHERS</b>													
UC4448N-18M	two doors	48"	31.5"	34.25"	10.7	18	1/5	7.2	115	5-15P	316	110	\$7,762
UCD4448N-18M	four drawers	48"	31.5"	34.25"	10.7	18	1/5	7.2	115	5-15P	398	110	\$10,867
<b>60" MEGA TOP FRONT BREATHERS</b>													
UC4460N-12M	two doors	60"	31.5"	34.25"	15.7	12	1/2	12.0	115	5-15P	411	110	\$8,105
UCD4460N-12M	four drawers	60"	31.5"	34.25"	15.7	12	1/2	12.0	115	5-15P	495	110	\$11,215
UC4460N-18M	two doors	60"	31.5"	34.25"	15.7	18	1/2	12.0	115	5-15P	411	110	\$8,311
UCD4460N-18M	four drawers	60"	31.5"	34.25"	15.7	18	1/2	12.0	115	5-15P	495	110	\$11,423
UC4460N-24M	two doors	60"	31.5"	34.25"	15.7	24	1/2	12.0	115	5-15P	411	110	\$8,507
UCD4460N-24M	four drawers	60"	31.5"	34.25"	15.7	24	1/2	12.0	115	5-15P	495	110	\$11,619
<b>64" MEGA TOP FRONT BREATHERS</b>													
UC4464N-12M	two doors	64"	31.5"	34.25"	16.7	12	1/2	12.0	115	5-15P	421	110	\$8,694
UCD4464N-12M	four drawers	64"	31.5"	34.25"	16.7	12	1/2	12.0	115	5-15P	522	110	\$11,817
UC4464N-18M	two doors	64"	31.5"	34.25"	16.7	18	1/2	12.0	115	5-15P	421	110	\$8,910
UCD4464N-18M	four drawers	64"	31.5"	34.25"	16.7	18	1/2	12.0	115	5-15P	522	110	\$12,027
UC4464N-24M	two doors	64"	31.5"	34.25"	16.7	24	1/2	12.0	115	5-15P	421	110	\$9,107
UCD4464N-24M	four drawers	64"	31.5"	34.25"	16.7	24	1/2	12.0	115	5-15P	522	110	\$12,222
<b>72" MEGA TOP FRONT BREATHERS</b>													
UC4472N-18M	three doors	72"	31.5"	34.25"	18.7	18	1/2	12.0	115	5-15P	461	110	\$9,320
UCD4472N-18M	six drawers	72"	31.5"	34.25"	18.7	18	1/2	12.0	115	5-15P	545	110	\$13,384
UC4472N-24M	three doors	72"	31.5"	34.25"	18.7	24	1/2	12.0	115	5-15P	461	110	\$9,517
UCD4472N-24M	six drawers	72"	31.5"	34.25"	18.7	24	1/2	12.0	115	5-15P	545	110	\$13,578
UC4472N-30M	three doors	72"	31.5"	34.25"	18.7	30	1/2	12.0	115	5-15P	461	110	\$9,714
UCD4472N-30M	six drawers	72"	31.5"	34.25"	18.7	30	1/2	12.0	115	5-15P	545	110	\$13,782

UC4400NM Series accessories and modifications can be found on page 46.

### Additional Warranties

Net Pricing

One year parts and labor contract ---\$279

Two year parts and labor contract --\$523

Five year compressor warranty  
 1/5 H.P. -----\$108  
 1/2 H.P. -----\$139





# 18600PTBM - STANDARD PIZZA AND PREP STATIONS

## 18600PTL - LIQUITEC® COOLED PREP TABLES

### 18600PDL - DUAL RAIL PREP TABLES

### CTP-NB - COUNTERTOP PREP RAILS

#### Product Information

##### PTBM, PDL & PTL SERIES ONLY

- Top and sides are constructed of stainless steel
- Back of unit is galvanized
- Pans and adapter bars by others
- High density environmentally friendly, Kyoto Protocol Compliant, Non ODP (Ozone Depletion Potential), Non GWP (Global Warming Potential) polyurethane foam throughout unit
- Stainless steel removable hinged covers
- Unit on/off switch is located behind the louver
- Front louvered panel has 1.50" hole for rail on/off switch access
- Protective rubber bumpers are affixed to the back of the unit
- 8' long electrical cord
- Environmentally friendly HFC-404A refrigerant
- One year parts and 90 day labor standard warranty. Additional warranties available, see below

##### PTBM SERIES ONLY

- Mechanically cooled
- Pans are recessed 2"
- NSF7 certified
- Die-stamped openings to accommodate 12" x 20" hotel pans or fractional pans

##### PTL SERIES ONLY

- LiquiTec® cooled flush mount rail with NSF7 certified performance
- Pans are flush mounted
- Standard Polyethylene cutting board

##### CTP-NB SERIES ONLY

- HFC-134A refrigerant is used
- 18-gauge exterior
- Mechanically cooled
- Pans are recessed 3"
- NSF7 certified
- One year parts and 90 day labor standard warranty. Additional warranties available, see below

##### PDL ONLY:

- 4.12" casters
- 34" standard work height
- Stainless steel finished ends
- LiquiTec® cooled flush mount rail with NSF7 certified performance
- Pans are flush mounted
- 17" wide polyethylene cutting board
- Five year compressor warranty
- One year parts and labor standard warranty. Additional warranties available, see below



18660PTBM



CTP8146NB



18672PDL

#### Specifications and Prices

MODEL NUMBER	1/3 PAN CAP.	OVERALL L	OVERALL D	OVERALL H	STOR CU. FT.	# OF DOORS	H.P.	AMP	VOLTS	NEMA PLUG	SHIP WEIGHT	FREIGHT CLASS	LIST PRICE
--------------	--------------	-----------	-----------	-----------	--------------	------------	------	-----	-------	-----------	-------------	---------------	------------

##### MECHANICALLY COOLED REFRIGERATED PIZZA & SANDWICH TABLES

Remote units available — See accessory pricing.

##### Self-Contained

18648PTBM	6	48"	31.5"	42"	8.39	1	1/4	10.0	115	5-15P	520	110	\$11,601
18660PTBM	7	60"	31.5"	42"	14.37	2	1/3	12.0	115	5-15P	580	110	\$12,278
18672PTBM	9	72"	31.5"	42"	16.77	2	1/2	14.0	115	5-20P	635	110	\$13,270
18691PTBM	11	91"	31.5"	42"	22.82	3	1/2	14.0	115	5-20P	770	110	\$15,963
18699PTBM	12	99"	31.5"	42"	25.87	3	1/2	14.0	115	5-20P	805	110	\$16,565
186114PTBM	14	114"	31.5"	42"	30.9	3	3/4	16.0	115	5-20P	927	110	\$19,968

MODEL NUMBER	OVERALL L	OVERALL D	OVERALL H	1/3 PAN CAPACITY	STOR CU. FT.	# OF DOORS	H.P.	AMP	VOLTS	NEMA PLUG	SHIP WEIGHT	FREIGHT CLASS	LIST PRICE
--------------	-----------	-----------	-----------	------------------	--------------	------------	------	-----	-------	-----------	-------------	---------------	------------

##### LIQUITEC COOLED PREP TABLES

##### Self-Contained

18648PTL	48"	31.5"	42"	6	8.39	1	1/4	10	115	5-15P	520	110	\$14,481
18672PTL	72"	31.5"	42"	9	16.77	2	1/2	14	115	5-20P	635	110	\$17,441
18699PTL	99"	31.5"	42"	12	25.87	3	1/2	14	115	5-20P	805	110	\$21,046

MODEL NUMBER	OVERALL L	OVERALL D	OVERALL H	H.P.	AMPS	NEMA PLUG	SHIP WEIGHT	LIST PRICE
--------------	-----------	-----------	-----------	------	------	-----------	-------------	------------

##### DUAL RAIL LIQUITEC PREP TABLES

18648PDL	48" (122cm)	31.50" (80cm)	52.8" (134cm)	1/5, 1/3	10.0	5-15P	691	\$16,731
18672PDL	72" (183cm)	31.50" (80cm)	52.8" (134cm)	1/5, 1/2	12.7	5-20P	875	\$19,483

MODEL NUMBER	OVERALL L	OVERALL D	OVERALL H	1/3 PAN CAPACITY	ADAPTER BARS	H.P.	AMP	VOLTS	NEMA PLUG	SHIP WEIGHT	FREIGHT CLASS	LIST PRICE
--------------	-----------	-----------	-----------	------------------	--------------	------	-----	-------	-----------	-------------	---------------	------------

##### COUNTERTOP REFRIGERATED PREP RAILS

##### Self-Contained

CTP 8146-NB	46"	17.03"	12.55"	4	5	1/5	4.0	115	5-15P	121	110	\$6,665
CTP 8160-NB	60"	17.03"	12.55"	6	7	1/5	4.0	115	5-15P	158	110	\$7,146

18600PTBM, 18600PTL, 18600PDL AND CTP/NB Series accessories and modifications can be found on page 47.

#### Additional Warranties

Net Pricing

One year parts and labor contract --- \$279

Two year parts and labor contract -- \$523

Five year compressor warranty

1/5 H.P. ----- \$108

1/4 H.P. ----- \$108

1/3 H.P. ----- \$128

1/2 H.P. ----- \$139

3/4 H.P. ----- \$145

# PREP TABLE ACCESSORIES/OPTIONS

## 4400N SERIES - MEGA & SALAD TOP

Electrical (transformers shipped loose, not installed at factory)

420021 230 volt, 50 cycle electrical system	-----	\$432
AS000-B88-0032 220/60/1 Voltage package	-----	\$1,273
Composite cutting board 1/2" thick		
27"	-----	\$198
32"	-----	\$235
48"	-----	\$359
60"	-----	\$443
64"	-----	\$460
72"	-----	\$539

Plastic laminate front (specify color on original order)

A130147827 27"	-----	\$293
A130147832 32"	-----	\$318
A130147848 48"	-----	\$421
A130147860 60"	-----	\$496
A130147864 64"	-----	\$519
A130147872 72"	-----	\$569

Plastic laminate back (specify color on original order)

A130147827B 27"	-----	\$293
A130147832B 32"	-----	\$318
A130147848B 48"	-----	\$421
A130147860B 60"	-----	\$496
A130147864B 64"	-----	\$519
A130147872B 72"	-----	\$569

Stainless steel back

A000-B4V-003N 27"	-----	\$530
A000-B4V-003P 32"	-----	\$580
A000-B4V-003R 48"	-----	\$770
A000-B4V-003T 60"	-----	\$972
A000-B4V-003U 64"	-----	\$1,023
A000-B4V-003W 72"	-----	\$1,119

Shelves

AS3978273 Additional shelf (48", 72")	-----	\$80
AS3978274 Additional shelf (27")	-----	\$80
AS3978275 Additional shelf (60")	-----	\$80
AS3978276 Additional shelf (32", 64")	-----	\$80

420104 Door lock original order only; (not available on glass doors)  
not field-installable; 1 section-----

420102 Door lock original order only; (not available on glass doors)  
not field-installable; 2&3 section-----

Remote configuration (condensing unit by others)-----Deduct \$525  
4400EXTHERM Exterior thermometer (door models only)-----\$488

Tray slides

Unit ready for field mounting of tray slides by others  
(requires stainless steel back option also)-----\$384

3 rail tray slide supplied by Delfield with unit ready for field installation  
(requires stainless steel back option also)

27"	-----	\$1,402
32"	-----	\$1,450
48"	-----	\$1,561
60"	-----	\$1,630
64"	-----	\$2,210
72"	-----	\$2,348

Solid V tray slide supplied by Delfield with unit ready for field installation  
(requires stainless steel back option also)

27"	-----	\$1,172
32"	-----	\$1,256
48"	-----	\$1,451
60"	-----	\$1,575
64"	-----	\$1,934
72"	-----	\$1,969

Glass Doors - Available for refrigerators only

(If interior light is required, it must be ordered as an option)

4400GLSDR24 24"	-----	\$698
4400GLSDR27 27"	-----	\$785
4400GLSDR30 30"	-----	\$875
4400GLSDR32 32"	-----	\$930

Drawers in place of doors

A000-B4Y-0030 Set of two 24"	-----	Add \$1,503 per door
A000-B4Y-0030 Set of two 30"	-----	Add \$1,503 per door
A000-B4Y-0030 Set of two 32"	-----	Add \$1,503 per door

Cutting board on rear in addition to front - 1/2" thick

(Requires stainless steel back option and flat lift off covers)

Size	Polyethylene	Composite
27"	-----	\$488
32"	-----	\$627
48"	-----	\$906
60"	-----	\$1,088
64"	-----	\$1,172
72"	-----	\$1,298

Pan covers

Flat lift off	-----	N/C
Hinged flat (Salad top units only)	-----	N/C
Hinged flat slide back	4427PANHS 27"	\$140
(Mega top units only, per pan opening)	4432PANHS 32"	\$173
	4448PANHS 48"	\$214
	4460PANHS 60"	\$244
	4464PANHS 64"	\$279
	4472PANHS 72"	\$313

Stainless steel overshelves

Single tier		
	27"	\$355
	32"	\$385
	48"	\$559
	60"	\$657
	64"	\$732
	72"	\$809
Double tier		
	27"	\$711
	32"	\$770
	48"	\$1,118
	60"	\$1,314
	64"	\$1,465
	72"	\$1,617

Non-standard pan cutout locations

(see accessory sheet for possible locations)-----Add \$558

### Drawer configurations for 4400N series only.

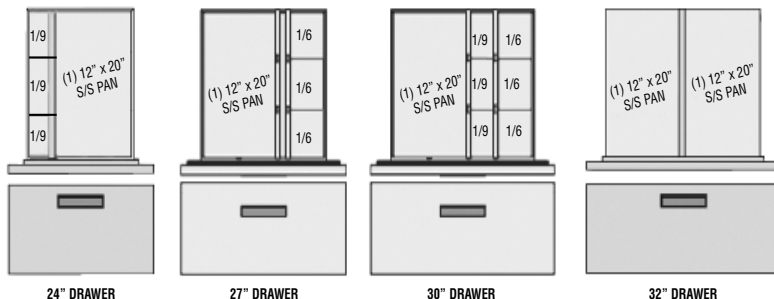

## PTBM AND PTL MODELS

Stainless steel back (per linear foot)-----	\$261
Laminate facing for units; per linear foot-----	\$126
(Laminate facing for rear of units requires stainless steel back)	
Cheese grates with removable catch pans (per linear foot)-----	\$503
Door/Drawer locks -----	\$366/lock
Composite cutting board (20" wide x 1/2" thick)	
48"-----	\$928
60"-----	\$1,087
72"-----	\$1,313
91"-----	\$1,617
99"-----	\$1,856
114"-----	\$2,130
Polyethylene cutting board (20" wide x 1/2" thick) Standard on PTL & PDL	
48"-----	\$464
60"-----	\$542
72"-----	\$656
91"-----	\$800
99"-----	\$929
114"-----	\$1,066
18" wide single tier overshef	
48"-----	\$884
60"-----	\$1,108
72"-----	\$1,328
91"-----	\$1,684
99"-----	\$1,830
114"-----	\$2,115
Drawers 19", 2 high, hold one 12" x 20" x 6" deep pan per drawer (pans supplied by others)-----	\$2,534
Drawers 19", 3 high, hold one 12" x 20" x 4" deep pan per drawer (pans supplied by others)-----	\$3,269
Drawers 27", 2 high, hold two 12" x 20" x 6" deep pans per drawer (pans supplied by others)-----	\$2,678
Drawers 27", 3 high, hold two 12" x 20" x 4" deep pans per drawer (pans supplied by others)-----	\$3,400
Drawers 32", 2 high, hold two 12" x 20" x 6" deep pans per drawer (pans supplied by others)-----	\$2,678
Drawers 32", 3 high, hold two 12" x 20" x 4" deep pans per drawer (pans supplied by others)-----	\$3,400
Remote refrigeration Overall unit length remains the same.	
Delete 1/4, 1/3 and 1/2 horsepower system-----	CREDIT \$618
Delete 3/4 horsepower system-----	CREDIT \$751
TR9B tray rack - 24" size door or larger only (Base support style for 18" x 26" trays; 2" centers;)-----	\$322
<b>Electrical-</b>	
230 volt, 50 cycle electrical system (allow approximately 4 weeks lead time)-----	\$431
220/60/1 voltage package (transformers shipped loose, not installed at factory)-----	\$1,204

## CTP-NB MODELS

Laminate facing for CTP models	
46"-----	\$397
60"-----	\$469
75"-----	\$696

### Electrical

230 volt, 50 cycle electrical system (allow approx. 4 weeks lead time)-----	\$422
--	-------

## PDL MODELS

Stainless steel back	
-48"-----	\$1,046
-72"-----	\$1,569
Tray racks -----	\$322/door
Composite cutting board in lieu of standard -----	
-48"-----	\$604
-72"-----	\$907
6" (15cm) legs or casters-----	\$350
Cheese grates with removable catch pans-----	\$503/ft
27" wide refrigerated drawers (2) high, holds 6" deep pans-----	\$2,678/section
Door/Drawer locks -----	\$366/lock
220V/50 cycle electrical system-----	\$431
Additional Shelves -----	\$200/ea
Remote refrigeration overall unit length remains the same.	
18648PDL-----	CREDIT \$1,057
18672PDL-----	CREDIT \$1,329

### Drawer configurations for PTBM, PDL and PTL series.

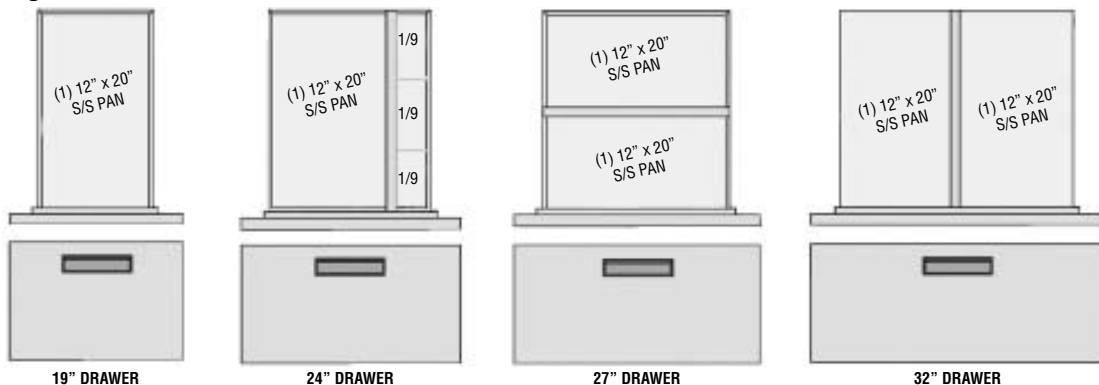



**F26/F27 Series** - Standard Low Profile  
Freezer Base Equipment Stands

**F28/F29 Series** - Low Profile  
Refrigerated Base Equipment Stands



# F28/F29 SERIES - REFRIGERATOR BASE EQUIPMENT STANDS

## F26/F27 SERIES - FREEZER BASE EQUIPMENT STANDS

### Product Information

- Top is 18-gauge stainless steel, with integral full perimeter marine edge
- Standard stainless steel ends
- High density polyurethane foam insulation throughout unit
- Refrigerated/freezer base fronts are made of .095" thick ABS plastic backed by rigid polyurethane water blown injection molded frames (NO WOOD)
- Exterior drawer fronts are stainless steel with an Delrite ABS plastic liner
- Snap-in dart style vinyl magnetic gasket
- Drawer handles are recessed black plastic held in with a positive lock system
- 14-gauge leg rails run the entire length of the unit
- Self-contained refrigerators come standard on 300 pound casters with optional 6.12" adjustable full stainless steel legs and bullet feet
- Remote units are standard on legs
- 8' cord and plug supplied
- Base interior cabinet is cooled with mullion style coated blower coil(s) mounted between each door/drawer section for even air and temperature control
- Blower coil enclose refrigeration lines, evaporator coil, expansion valve and fans
- Interior refrigerated base cabinet section to maintain 36° to 40° meeting NSF7 requirements
- Digital thermometer
- Electric condensate evaporators are standard
- Optional 220V-50 cycle available
- Wall-mounted bracket to prevent tipping
- Full Extension Plus Drawer system is a complete drawer system. Drawer system is sized to hold 12" x 20" x 4" deep hotel pans (by others). The drawer system is all stainless steel construction for maximum durability
- F26/2700 base cabinet will maintain 0° to -5° temperatures at 100° ambient room temperature meeting NSF7 requirements
- When ordering, specify make, model and depth of cooking equipment sitting on the equipment stand
- Height of surface for setting equipment is 25.50"
- Self-contained freezers are standard with a defrost timer
- Environmentally friendly HFC-404A refrigerant
- One year parts and 90 day labor standard warranty. Additional warranties available, see below



**F2980**  
Shown with optional legs



**FULL EXTENSION PLUS DRAWER SYSTEM!**

**10-year Warranty on Delfield's Full Extension Plus Drawer System Track!**

### Specifications and Prices

MODEL NUMBER	OVERALL			# OF DRAWERS	PAN CAP.	H.P.	AMP	VOLTS	NEMA PLUG	SHIP WEIGHT	FREIGHT CLASS	LIST PRICE
	L	D	H									
<b>LOW-PROFILE REFRIGERATED BASE EQUIPMENT STANDS</b>												
<b>Self-Contained</b> NOTE: Remove the "C" on the model number when ordering with legs. (Example - F2952).												
F2952C	52.25"	31"	26"	(2) 32"	4	1/5	8.0	115	5-15P	398	110	\$14,041
F2956C	56.25"	31"	26"	(2) 32"	4	1/5	8.0	115	5-15P	405	110	\$14,095
F2962C	62.25"	31"	26"	(2) 27" (2) 19"	6	1/5	8.0	115	5-15P	479	110	\$16,318
F2975C	75.25"	31"	26"	(2) 32" (2) 27"	8	1/4	10.0	115	5-15P	540	110	\$16,868
F2980C	80.25"	31"	26"	(4) 32"	8	1/4	10.0	115	5-15P	578	110	\$17,192
F2987C	87.25"	31"	26"	(4) 27" (2) 19"	10	1/4	10.0	115	5-15P	672	110	\$19,782
F2999C	99.25"	31"	26"	(6) 27"	12	1/4	10.0	115	5-15P	691	110	\$20,074
F29110C	110.25"	31"	26"	(6) 32"	12	1/4	10.0	115	5-15P	766	110	\$20,315
<b>Remote</b>												
F2852	52.25"	31"	26"	(2) 19" (2) 27"	4	N/A	3.0	115	N/A	278	110	\$11,841
F2856	56.25"	31"	26"	(2) 32"	4	N/A	3.0	115	N/A	299	110	\$11,892
F2862	62.25"	31"	26"	(2) 27" (2) 19"	6	N/A	3.0	115	N/A	331	110	\$14,118
F2875	75.25"	31"	26"	(2) 32" (2) 27"	8	N/A	3.0	115	N/A	401	110	\$14,497
F2880	80.25"	31"	26"	(4) 32"	8	N/A	3.0	115	N/A	428	110	\$14,823
F2887	87.25"	31"	26"	(4) 27" (2) 19"	10	N/A	6.0	115	N/A	466	110	\$17,679
F2899	99.25"	31"	26"	(6) 27"	12	N/A	6.0	115	N/A	530	110	\$17,967
F28110	110.25"	31"	26"	(6) 32"	12	N/A	6.0	115	N/A	588	110	\$18,209
<b>LOW-PROFILE FREEZER BASE EQUIPMENT STANDS</b>												
<b>Self-contained</b>												
F2660	60.25"	31"	26"	(2) 32"	4	1/2	11.0	115	5-15P	418	110	\$17,437
F2694	94.25"	31"	26"	(4) 32"	8	3/4	16.0	115	5-20P	505	110	\$21,122
<b>Remote</b>												
F2748	48.25"	31"	26"	(2) 32"	4	N/A	10.0	115	N/A	295	110	\$15,143
F2776	76.25"	31"	26"	(4) 32"	8	N/A	15.0	115	N/A	375	110	\$18,491

F26, 27, 28, 29 Series accessories and modifications can be found on page 50.

<b>Additional Warranties</b>	
Net Pricing	
One year parts and labor contract ---	\$279
Two year parts and labor contract --	\$523
Five year compressor warranty	
1/5 H.P. -----	\$108
1/4 H.P. -----	\$108
1/2 H.P. -----	\$139
3/4 H.P. -----	\$145

# EQUIPMENT STAND ACCESSORIES

## F26, F27, F28, F29 SERIES

505H	Stainless steel back-----	per linear inch \$20
108	Drawer locks (factory installed only; each)-----	\$366
122K	230 volt, 50 cycle electrical system-----	\$1,032
414	Mechanical housing left side-----	\$374

### F26 Series only

To add 6" casters for self-contained low-profile equipment stand add "-C" suffix to model number

1027A	Set of 4 casters (F26 Series)-----	\$722
1027C	Set of 6 casters (F26 Series)-----	\$1,087
1027H	4" casters in lieu of 6" (F29 Series)-----	\$226

Doors in lieu of drawers except 32"

104A	19" door, low profile-----	\$631
104C	27" door, low profile-----	\$668
906E	Plastic laminate end-----	\$587
505A	Plastic laminate back-----	per linear inch \$24
505F	Plastic laminate front-----	per linear inch \$15

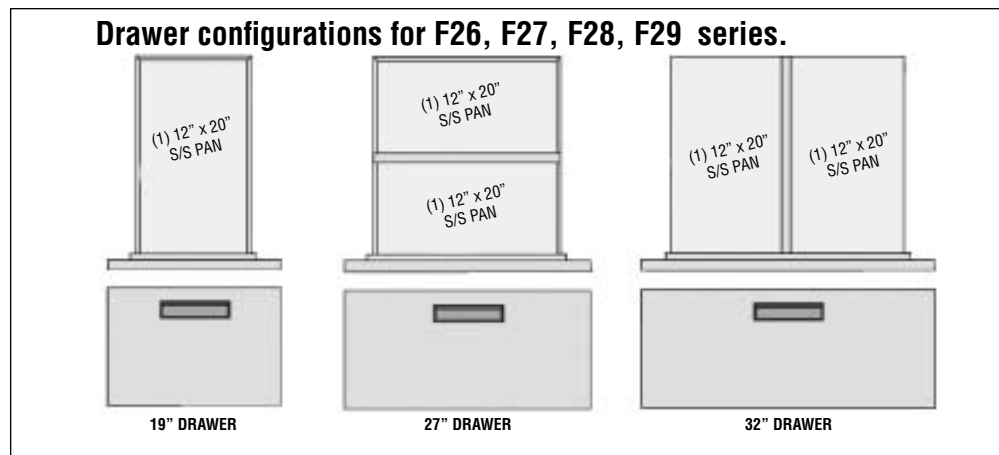



**ECOS** - Open Shelf Utility Modules

**ECSR24** - Sink Module

**EHEI** - Hot Food Table Modules

**ESOS** - Open Shelf Utility Module

**EODC** - Open Shelf Utility With Double  
Tier Cantilevered Overshelf  
Modules

**ESIC36** - Ice Pan Module

**ESSW36** - Soupwell Module



# EHEI-E-CHEF HOT FOOD TABLE

## ECSR24-E-CHEF SINK MODULE

## ECOS-E-CHEF OPEN SHELF MODULE



ECOS36



EHEI36C

### Product Information

#### All Units

- One year parts and labor warranty

#### EHEI only

- Stainless steel top and sides
- Individual wells with infinite controls
- 8" polyethylene cutting board
- Drains, manifold and common gate valve
- Stainless steel plate shelf
- Stainless steel bottom shelf with 3" riser at rear
- Models on casters (C) standard with cord and plug
- Models on legs (L) must be hard wired in field

#### Sink Units only

- Stainless steel top and sides
- Stainless steel bottom shelf with 3" riser at the rear
- Standard on legs
- 10"x13" x6.5" sink with deck mount faucet
- 3-sided removable sink riser standard

#### ECOS only

- Stainless steel top and sides
- Stainless steel bottom and center shelf with 3" riser at the rear
- Standard on 6" legs

### Specifications and Prices

#### Hot Food Tables

Model	L	D	H	# of Wells	Volts	Amps	Nema Plug	Ship Weight	Freight Class	List Price
EHEI36L	36"	31.5"	36"	2	120	17.0	N/A	250	100	\$3,999
EHEI48L	48"	31.5"	36"	3	208/230	15.0	N/A	280	100	\$5,053
EHEI60L	60"	31.5"	36"	4	208/230	20.0	N/A	310	100	\$6,081
EHEI74L	74"	31.5"	36"	5	208/230	24.0	N/A	350	100	\$7,232
EHEI36C	36"	31.5"	36"	2	120	17.0	5-30P	250	100	\$4,197
EHEI48C	48"	31.5"	36"	3	208/230	15.0/16.0	6-20P	280	100	\$5,206
EHEI60C	60"	31.5"	36"	4	208/230	20.0/22.0	6-30P	310	100	\$6,315
EHEI74C	74"	31.5"	36"	5	208/230	24.0/27.0	6-50P	350	100	\$7,425

#### Chef Side Sink Module

Model	L	D	H	Ship Weight	Freight Class	List Price
ECSR24	24"	31.5"	36"	200	125	\$3,120

#### Chef Side Open Shelf Module

Model	L	D	H	Ship Weight	Freight Class	List Price
ECOS24	24"	31.5"	36"	200	125	\$2,516
ECOS36	36"	31.5"	36"	220	125	\$2,745
ECOS48	48"	31.5"	36"	250	125	\$2,969

Accessories and Options can be found on page 54.

#### Additional Warranties Net Pricing

Two year parts and  
labor contract -- \$523





# ESSW36 & EODC36S-E-CHEF SOUP WELL MODULE ESIC36 & EODC36I-E-CHEF ICE COOLED COLD PAN MODULE ESOS & EODC-E-CHEF OPEN SHELF MODULES

## Product Information

### All Units

- One year parts and labor warranty

### Soup Well Units only

- Stainless steel top and sides
- Individual wells with infinite controls
- Drain and gate valve standard
- Stainless steel bottom shelf with 3" riser at the rear
- Standard on flanged feet
- Standard with removable adapter plate to accommodate (2) 8.5" diameter pans

### Ice Cooled Pan Units only

- Stainless steel top and sides
- Stainless steel bottom shelf with 3" riser at rear
- 1" drain is standard
- Removable stainless steel perforated bottom standard
- Standard on flanged feet
- 2" recessed integral pan rest

- Single well ice pan to accommodate (1) 12"x20" pan

### ESOS only

- Stainless steel top and sides
- Stainless steel bottom and center shelf with 3" riser at the rear
- Standard on flanged feet

### EODC only

#### Base:

- Stainless steel top and sides
- Stainless steel bottom and center shelf with 3" riser at the rear
- Standard on flanged feet

#### Overshelf:

- Double tier cantilevered overshelf welded in place
- Stainless steel shelves and legs
- Integral brace raceway under each shelf for field added components



**ESOS27**

## Specifications and Prices

### Server Side Soup Well Module

Model	L	D	H	# of Soup wells	Volts	Amps	Ship Weight	Freight Class	List Price
ESSW36	36"	20"	34"	1	120	17.0	200	125	\$3,407

### Soup Well Module with Double Tier Overshelf

EODC36S	36"	28"	70"	1	120	17.0	250	125	\$6,638
---------	-----	-----	-----	---	-----	------	-----	-----	---------

### Server Side Ice Cooled Cold Pan Module

Model	L	D	H	# of Wells	Ship Weight	Freight Class	List Price
ESIC36	36"	20"	34"	1	200	125	\$2,855

### Ice Cooled Cold Pan Module with Double Tier overshelf

EODC36I	36"	28"	70"	1	250	125	\$5,293
---------	-----	-----	-----	---	-----	-----	---------

### Server Side Open Shelf Module

Model	L	D	H	Ship Weight	Freight Class	List Price
ESOS24	24"	20"	34"	150	125	\$2,352
ESOS27	27"	20"	34"	155	125	\$2,387
ESOS32	32"	20"	34"	160	125	\$2,449
ESOS36	36"	20"	34"	170	125	\$2,496
ESOS48	48"	20"	34"	200	125	\$2,646
ESOS60	60"	20"	34"	230	125	\$2,794
ESOS64	64"	20"	34"	240	125	\$2,844
ESOS72	72"	20"	34"	260	125	\$2,942
ESOS74	74"	20"	34"	265	125	\$2,976

### Server Side Open Shelf Base with Double Tier Overshelf

Model	L	Base D	Overshelf D	H	Ship Weight	Freight Class	List Price
EODC24	24"	20"	28"	70"	200	125	\$3,513
EODC27	27"	20"	28"	70"	225	125	\$3,554
EODC32	32"	20"	28"	70"	240	125	\$3,659
EODC36	36"	20"	28"	70"	250	125	\$3,857
EODC48	48"	20"	28"	70"	280	125	\$4,365
EODC60	60"	20"	28"	70"	320	125	\$4,943
EODC64	64"	20"	28"	70"	330	125	\$5,263
EODC72	72"	20"	28"	70"	360	125	\$5,663
EODC74	74"	20"	28"	70"	370	125	\$6,127

Accessories and Options can be found on page 54.

#### Additional Warranties

Net Pricing

Two year parts and labor contract ----- \$523

## Accessory

### List Price

<b>EOSM24</b> Overshelf single tier microwave shelf, 24" .....	\$502
<b>EORW14</b> Top shelf vertical raceway, 14" .....	\$197
<b>EORW18</b> Bottom shelf vertical raceway, 18" .....	\$202
<b>EORW24</b> Top shelf to ceiling vertical raceway, 24" .....	\$212
<b>EORW36</b> Top shelf to ceiling vertical raceway, 36" .....	\$231
<b>EORW48</b> Top shelf to ceiling vertical raceway, 48" .....	\$252
<b>ESRW24</b> Server side horizontal raceway, 24" .....	\$142
<b>ESRW27</b> Server side horizontal raceway, 27" .....	\$144
<b>ESRW32</b> Server side horizontal raceway, 32" .....	\$147
<b>ESRW36</b> Server side horizontal raceway, 36" .....	\$153
<b>ESRW48</b> Server side horizontal raceway, 48" .....	\$162
<b>ESRW60</b> Server side horizontal raceway, 60" .....	\$172
<b>ESRW64</b> Server side horizontal raceway, 64" .....	\$177
<b>ESRW72</b> Server side horizontal raceway, 72" .....	\$184
<b>ESRW74</b> Server side horizontal raceway, 74" .....	\$188
<b>ECFP</b> Stainless steel end filler panel.....	\$135
<b>ECPB48</b> Partial stainless steel back for 18648PTB .....	\$175
<b>ECPB60</b> Partial stainless steel back for 18660PTB .....	\$188
<b>ECPB72</b> Partial stainless steel back for 18672PTB .....	\$201
<b>ECPB91</b> Partial stainless steel back for 18691PTB .....	\$222
<b>ECPB99</b> Partial stainless steel back for 18699PTB .....	\$231
<b>ECPB114</b> Partial stainless steel back for 186114PTB .....	\$248
<b>ETM</b> - E-Chef Stainless Steel T-molding, 12' length.....	\$94
<b>ESSB24-</b> Server side stainless steel back 24" .....	\$228
<b>ESSB27-</b> Server side stainless steel back 27" .....	\$253
<b>ESSB32-</b> Server side stainless steel back 32" .....	\$293
<b>ESSB36-</b> Server side stainless steel back 36" .....	\$318
<b>ESSB48-</b> Server side stainless steel back 48" .....	\$406
<b>ESSB60-</b> Server side stainless steel back 60" .....	\$494
<b>ESSB64-</b> Server side stainless steel back 64" .....	\$519
<b>ESSB72-</b> Server side stainless steel back 72" .....	\$582
<b>ESSB74-</b> Server side stainless steel back 74" .....	\$596
<b>ECSB24-</b> Chef side stainless steel back 24" .....	\$233
<b>ECSB36-</b> Chef side stainless steel back 36" .....	\$323
<b>ECSB48-</b> Chef side stainless steel back 48" .....	\$412
<b>ECSB60-</b> Chef side stainless steel back 60" .....	\$500
<b>ECSB74-</b> Chef side stainless steel back 74" .....	\$602
<b><u>EHEI Options</u></b>	
<b>Fill faucet</b> .....	\$278
<b>208V/60C or 230V/50C</b> electrical (EHEI36L &EHEI36C only).....	\$294
<b>Cord and Plug</b> (units on legs only) .....	\$603
<b>Composite 8" deep cutting boards in lieu of standard polyethylene</b>	
36" .....	\$260
48" .....	\$348
60" .....	\$435
74" .....	\$535



**ASM Series** - Drop-In Air Screen Merchandisers

**F5 Series** - Drop-In Display Cases

**F15 Series** - Servview Display Cases



Display Cases

# ASM SERIES - DROP-IN REFRIGERATED AIR SCREEN MERCHANDISER



**ASM-48**

shown with optional Shelley base

## Product Information

- All glass display area and top slim line fluorescent lighting showcases product
- Bottom shelf is a recessed pan, perfect for bottles or taller items
- Three 1" adjustable glass shelves with fluorescent lights standard
- Slide out condensing unit allows for easy serviceability
- R404A refrigerant
- Shelves can be positioned three ways: completely flat, slanted and full tilt
- Drain requires hard plumbing (unless condensate evaporator option is selected)
- Sliding rear doors make replenishment and loading easy
- Meets NSF7 Type 2 requirements which maintains 33°F to 41°F temperature in 80°F environment with 55% relative humidity
- Standard with two louvers, shipped loose, for proper airflow in base
- One year parts and labor standard warranty

## Specifications and Prices

<i>Model Number</i>	<i>L</i>	<i>D</i>	<i>H</i>	<i>Cutout Dimension</i>	<i>H.P</i>	<i>V/Hz/Ph</i>	<i>Amps</i>	<i>NEMA Plug</i>	<i>Ship Weight</i>	<i>List price</i>
<b>DROP-IN AIR SCREEN MERCHANDISER</b>										
<b>ASM-36</b>	36.25"	26"	63.48"	35.00" x 25.38"	1/2	115V/60Hz/1Ph	10.8	5-15P	350lbs.	<b>\$25,585</b>
<b>ASM-48</b>	48.25"	26"	63.48"	47.00" x 25.38"	3/4	115V/60Hz/1Ph	12.8	5-20P	457lbs.	<b>\$27,064</b>
<b>ASM-60</b>	60.25"	26"	66.48"	59.00" x 25.38"	1	115/208-230V/60Hz/1Ph	12.8	14-20P	593lbs.	<b>\$29,527</b>

### Additional Warranties

Net Pricing

One year parts and labor contract --- \$279

Two year parts and labor contract -- \$523

Five year compressor warranty

1/2 H.P. ----- \$139

3/4 H.P. ----- \$145



# F5 SERIES - DROP IN REFRIGERATED DISPLAY CASES

## Product Information

- Display exterior sides are made of 18-gauge stainless steel
- ABS plastic interior sides with molded shelf supports
- (4) adjustable epoxy coated wire shelves
- On/off switch for the display section light(s)
- Top mount coil with multiple fans circulating the air throughout the cabinet
- Display section runs off a thermostat
- ABS plastic drip pan is placed below the coil with a clear drain hose for running the condensation to the lower base mechanical section
- Sliding and removable self-closing .50" thick argon filled, low-E, warm edge insert, thermopane glass doors with left and right vertical gasket
- High density polyurethane foam throughout unit
- Optional 220V-50 cycle
- "M" units have a single service display section with mirrored back. "S" units have a single service display section with a see-through back. "P" units have Pass-through display section with glass doors on both sides
- Environmentally friendly HFC-404A refrigerant
- One year parts and 90 day labor standard warranty. Additional warranties available, see below



F5SC48N

## Specifications and Prices

MODEL NUMBER	OVERALL			CAP. CU. FT.	SHLV. SQ. FT.	# OF SHLV.	H.P.	AMP	VOLTS	NEMA PLUG	SHIP WEIGHT	FREIGHT CLASS	LIST PRICE
	L	D	H										
<b>24" DEEP SELF-CONTAINED DROP-IN REFRIGERATED DISPLAY CASE</b>													
F5MC48N	48"	24"	57.5"†	14.3	18.8	4	1/2	12.0	115	5-15P	415	110	\$15,380
F5SC48N	48"	24"	57.5"†	14.3	20.8	4	1/2	12.0	115	5-15P	433	110	\$15,870
F5PC48N	48"	24"	57.5"†	14.3	20.8	4	1/2	12.0	115	5-15P	530	110	\$15,870
F5MC72N	72"	24"	57.5"†	22.2	29.2	4	3/4	16.0	115	5-20P	560	110	\$18,298
F5SC72N	72"	24"	57.5"†	22.2	32.8	4	3/4	16.0	115	5-20P	595	110	\$19,285
F5PC72N	72"	24"	57.5"†	22.2	32.8	4	3/4	16.0	115	5-20P	578	110	\$19,285
†Includes compressor housing													
<b>24" DEEP REMOTE DROP-IN REFRIGERATED DISPLAY CASES</b>													
F5MR48N	48"	24"	42"	14.3	18.8	4	N/A	4.0	115	N/A	390	100	\$13,640
F5SR48N	48"	24"	42"	14.3	20.8	4	N/A	4.0	115	N/A	408	100	\$14,140
F5PR48N	48"	24"	42"	14.3	20.8	4	N/A	4.0	115	N/A	398	100	\$14,140
F5MR72N	72"	24"	42"	22.2	29.2	4	N/A	4.0	115	N/A	535	110	\$16,560
F5SR72N	72"	24"	42"	22.2	32.8	4	N/A	4.0	115	N/A	570	110	\$17,558
F5PR72N	72"	24"	42"	22.2	32.8	4	N/A	4.0	115	N/A	553	110	\$17,557
<b>30" DEEP SELF-CONTAINED DROP-IN REFRIGERATED DISPLAY CASES</b>													
F5MC48D	48"	30"	57.5"†	19.0	26.0	4	1/2	12.0	115	5-15P	590	110	\$17,392
F5SC48D	48"	30"	57.5"†	19.0	28.2	4	1/2	12.0	115	5-15P	640	110	\$17,497
F5PC48D	48"	30"	57.5"†	19.0	28.2	4	1/2	12.0	115	5-15P	609	110	\$17,497
F5MC72D	72"	30"	57.5"†	29.4	40.5	4	3/4	16.0	115	5-20P	790	110	\$20,047
F5SC72D	72"	30"	57.5"†	29.4	44.0	4	3/4	16.0	115	5-20P	818	110	\$21,030
F5PC72D	72"	30"	57.5"†	29.4	44.0	4	3/4	16.0	115	5-20P	815	110	\$21,030
†Includes compressor housing													
<b>30" DEEP REMOTE DROP-IN REFRIGERATED DISPLAY CASES</b>													
F5MR48D	48"	30"	42"	19.0	26.0	4	N/A	4.0	115	N/A	485	110	\$15,056
F5SR48D	48"	30"	42"	19.0	28.2	4	N/A	4.0	115	N/A	540	110	\$15,549
F5PR48D	48"	30"	42"	19.0	28.2	4	N/A	4.0	115	N/A	497	110	\$15,549
F5MR72D	72"	30"	42"	29.4	40.5	4	N/A	4.0	115	N/A	644	110	\$17,819
F5SR72D	72"	30"	42"	29.4	44.0	4	N/A	4.0	115	N/A	680	110	\$18,792
F5PR72D	72"	30"	42"	29.4	44.0	4	N/A	4.0	115	N/A	652	110	\$18,792

F5 Series accessories and modifications can be found on page 59.

Additional Warranties	
Net Pricing	
One year parts and labor contract ---	\$279
Two year parts and labor contract --	\$523
Five year compressor warranty	
1/2 H.P. -----	\$139
3/4 H.P. -----	\$145

# F15 SERIES - REFRIGERATED DISPLAY CASE WITH STORAGE



**F15MC48N**  
Shown with optional  
finished ends

## Product Information

### DISPLAY CASE

- Display exterior sides are made of 18-gauge stainless steel
- ABS plastic interior sides with molded shelf supports
- (4) adjustable epoxy coated wire shelves
- On/off switch for the display section light(s)
- Top mount coil with multiple fans circulating the air throughout the cabinet
- Display section run off a thermostat
- ABS plastic drip pan is placed below the coil with a clear drain hose for running the condensation to the lower base mechanical section
- Sliding and removable self-closing .50" thick argon filled, low-E, warm edge insert, thermopane glass doors with left and right vertical gasket

### BASE

- Standard heavy duty units have unfinished base ends, for finished end options, see page 56
- Base top is constructed of 16-gauge stainless steel
- High density polyurethane foam throughout unit
- Refrigerated base fronts are made of .095" thick ABS plastic backed by rigid polyurethane water blown injection molded frames (NOWOOD)
- Epoxy coated shelf for each door
- Exterior door fronts are stainless steel with ABS plastic liner
- Snap-in dart style vinyl magnetic gasket

- Door handles are recessed black plastic and held in with a positive lock system
- 14-gauge leg rails that run the entire length of the unit
- 6.12" adjustable full stainless steel legs and bullet feet
- Base interior cabinet is cooled with mullion style coated blower coil(s) mounted between each door/drawer section for even air and temperature control
- Blower coil encloses refrigeration lines, evaporator coil, expansion valve, thermostat and fans
- Interior refrigerated base cabinet and display section to maintain 36° to 41° meeting NSF requirements
- Optional 220V-50 cycle
- "M" units have a single service display section with mirrored back. "S" units have a single service display section with a see-through back. "P" units have Pass-through display section with glass doors on both sides
- Environmentally friendly HFC-404A refrigerant
- One year parts and 90 day labor standard warranty. Additional warranties available, see below

## Specifications and Prices

MODEL NUMBER	OVERALL L	OVERALL D	OVERALL H	UPPER CU. FT.	SHLV. SQ. FT.	BASE CU. FT.	H.P.	AMP	VOLTS	NEMA PLUG	SHIP WEIGHT	FREIGHT CLASS	LIST PRICE
<b>30" DEEP UPPER DISPLAY SECTION</b>													
<b>Self-contained</b>													
F15MC48D	48"	31.5"	78"	19.0	26.0	8.7	3/4	16.0	115	5-20P	759	110	\$25,118
F15SC48D	48"	33.38"	78"	19.0	28.2	8.7	3/4	16.0	115	5-20P	786	110	\$26,942
F15PC48D	48"	33.38"	78"	19.0	28.2	8.7	3/4	16.0	115	5-20P	807	110	\$27,213
F15MC72D	72"	31.5"	78"	29.4	40.5	15.4	3/4	16.0	115	5-20P	1110	110	\$28,282
F15SC72D	72"	33.38"	78"	29.4	44.0	15.4	3/4	16.0	115	5-20P	1140	110	\$31,891
F15PC72D	72"	33.38"	78"	29.4	44.0	15.4	3/4	16.0	115	5-20P	1159	110	\$32,160
<b>Remote</b>													
F15MR48D	48"	31.5"	78"	19.0	26.0	12.2	N/A	4.0	115	N/A	708	110	\$21,308
F15SR48D	48"	33.38"	78"	19.0	28.2	12.2	N/A	4.0	115	N/A	728	110	\$22,776
F15PR48D	48"	33.38"	78"	19.0	28.2	12.2	N/A	4.0	115	N/A	749	110	\$23,045
F15MR72D	72"	31.5"	78"	29.4	40.5	19.4	N/A	4.0	115	N/A	961	110	\$24,659
F15SR72D	72"	33.38"	78"	29.4	44.0	19.4	N/A	4.0	115	N/A	986	110	\$28,137
F15PR72D	72"	33.38"	78"	29.4	44.0	19.4	N/A	4.0	115	N/A	980	110	\$28,408
<b>24" DEEP UPPER DISPLAY SECTION</b>													
<b>Self-contained</b>													
F15MC48N	48"	31.5"	78"	14.3	18.8	8.7	3/4	16.0	115	5-20P	748	110	\$23,498
F15SC48N	48"	33.38"	78"	14.3	20.8	8.7	3/4	16.0	115	5-20P	745	110	\$25,327
F15PC48N	48"	33.38"	78"	14.3	20.8	8.7	3/4	16.0	115	5-20P	787	110	\$25,595
F15MC72N	72"	31.5"	78"	22.2	29.2	15.4	3/4	16.0	115	5-20P	1080	110	\$26,661
F15SC72N	72"	33.38"	78"	22.2	32.8	15.4	3/4	16.0	115	5-20P	1108	110	\$30,273
F15PC72N	72"	33.38"	78"	22.2	32.8	15.4	3/4	16.0	115	5-20P	1129	110	\$30,543
<b>Remote</b>													
F15MR48N	48"	31.5"	78"	14.3	18.8	12.2	N/A	4.0	115	N/A	668	110	\$20,031
F15SR48N	48"	33.38"	78"	14.3	20.8	12.2	N/A	4.0	115	N/A	706	110	\$21,507
F15PR48N	48"	33.38"	78"	14.3	20.8	12.2	N/A	4.0	115	N/A	727	110	\$22,510
F15MR72N	72"	31.5"	78"	22.2	29.2	19.4	N/A	4.0	115	N/A	931	110	\$23,396
F15SR72N	72"	33.38"	78"	22.2	32.8	19.4	N/A	4.0	115	N/A	954	110	\$26,859
F15PR72N	72"	33.38"	78"	22.2	32.8	19.4	N/A	4.0	115	N/A	980	110	\$27,128

F15 Series accessories and modifications can be found on page 59.

### Additional Warranties

Net Pricing

One year parts and labor contract --- \$279

Two year parts and labor contract -- \$523

Five year compressor warranty  
3/4 H.P. ----- \$145



## F5 SERIES

122K	230 volt, 50 cycle electrical system-----	\$1,032
307A	Extra 48" shelf (48" long units only; each) -----	\$276
307B	Extra 72" shelf (72" long units only; each) -----	\$361
303A	Mirrored interior on pass-through doors (48")-----	\$1,122
303B	Mirrored interior on pass-through doors (72")-----	\$1,349
301	Hinged doors in lieu of sliding doors-----	Contact Factory

## F15 SERIES

307A	Extra 48" shelf (48" long units only; each) -----	\$276
307B	Extra 72" shelf (72" long units only; each) -----	\$361
303A	Mirrored interior on pass-through doors (48")-----	\$1,122
303B	Mirrored interior on pass-through doors (72")-----	\$1,349
122K	230 volt, 50 cycle electrical system-----	\$1,032
109	Condensate evaporator (2 required) remote units -----	\$278
906E	Plastic laminate end-----	\$587
505A	Plastic laminate back-----	per linear inch \$24
505F	Plastic laminate front-----	per linear inch \$15
818A	14-gauge top-----	per linear inch \$17
505H	Stainless steel back-----	per linear inch \$20
906A	Stainless steel end-----	each \$482

## ASM SERIES

ASMNC-36	(not field-installable) Night Security Cover -----	\$2,661
ASMNC-48	(not field-installable) Night Security Cover -----	\$2,693
ASMNC-60	(not field-installable) Night Security Cover -----	\$3,505
ASMCE-36	(not field-installable) Condensate evaporator (Cord spec for ASM-36 w/ condensate evap: Nema 14-20P @ 115-208/230V-60C-1PH-10.8A)-----	\$748
ASMCE-48	(not field-installable) Condensate evaporator (Cord spec for ASM-48 w/ condensate evap: Nema 14-20P @ 115-208/230V-60C-1PH-12.8A)-----	\$748
ASMCE-60	(not field-installable) Condensate evaporator (Cord spec for ASM-60 w/ condensate evap: Nema 14-50P @ 115/208-230V-60C-1PH-26A)-----	\$1,009
ASM220V	220V/50Hz electrical system-----	\$932
ASML	Laminated sides & top-----	\$799
ASMR	Remote (specify refrigerant)-----	(CREDIT) \$1,730



**Concepts™** - Serving Systems

**FlexiShield®** - Foodshields

**Shelleybasic®** - Value Serving Systems

**Shelleysteel®** - Stainless Steel Mobile  
Serving Equipment

**Shelleyglas®** - Fiberglass Mobile  
Serving Equipment

**Shelleyspeed®** - Speed Line Mobile  
Serving Equipment





# DCBU: CONCEPTS UTILITY SERVING COUNTERS

## DC-H: CONCEPTS HEATED SERVING COUNTERS

### Product Information

#### DCBU UNITS ONLY

- Heavy duty stainless steel top
- Reinforced stainless steel front and rear removable panels
- Heavy duty base support structure
- Standard on 6" legs
- 36" work height
- Must be hard wired in field
- 11.87" x 19.87" single hot food wells are manifolded together to one main gate valve
- Wet and dry operation
- Individual infinite temperature controls
- One year parts and labor standard warranty

#### DC-H UNITS ONLY

- Flush mount die stamped stainless steel heated food well
- 1/2" stainless steel drains
- Heavy duty stainless steel top
- Reinforced stainless steel front and rear with removable panels
- Heavy duty base support structure
- Standard on 6" legs

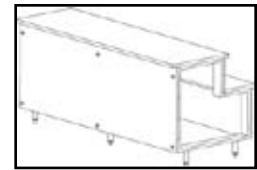

**DCBU-T60**



**DC-H4**

shown with an optional fill faucet

### Specifications and Prices

MODEL NUMBER	DESCRIPTION	OVERALL			SHIP WEIGHT	FREIGHT CLASS	LIST PRICE
		L	D	H			
<b>Utility counters - flat</b>							
DCBU-38	Utility base, 38" length	38"	36"	36"	171 lbs.	100	Contact Factory
DCBU-52	Utility base, 52" length	52"	36"	36"	234 lbs.	100	Contact Factory
DCBU-66	Utility base, 66" length	66"	36"	36"	297 lbs.	100	Contact Factory
DCBU-80	Utility base, 80" length	80"	36"	36"	360 lbs.	100	Contact Factory
DCBU-94	Utility base, 94" length	94"	36"	36"	423 lbs.	100	Contact Factory
DCBU-120	Utility base, 120" length	120"	36"	36"	540 lbs.	100	Contact Factory
<b>Utility counters - tiered</b>							
DCBU-T38	Utility base, 38" length tiered	38"	36"	36"	171 lbs.	100	Contact Factory
DCBU-T52	Utility base, 52" length tiered	52"	36"	36"	234 lbs.	100	Contact Factory
DCBU-T66	Utility base, 66" length tiered	66"	36"	36"	297 lbs.	100	Contact Factory
DCBU-T80	Utility base, 80" length tiered	80"	36"	36"	360 lbs.	100	Contact Factory
DCBU-T94	Utility base, 94" length tiered	94"	36"	36"	423 lbs.	100	Contact Factory
DCBU-T120	Utility base, 120" length tiered	120"	36"	36"	540 lbs.	100	Contact Factory

MODEL NUMBER	DESCRIPTION	OVERALL			12"x20" PAN CAP.	WATTS	AMP	VOLTS/HERTZ/ PHASE	SHIP WEIGHT	FREIGHT CLASS	LIST PRICE
		L	D	H							
<b>Heated counters</b>											
DC-H2	Heated unit, two wells	38"	36"	36"	2	2000	16.6	115/60/1	228 lbs.	85	Contact Factory
DC-H3	Heated unit, three wells	52"	36"	36"	3	3000/4000	15.0/16.0	208-230/60/1	312 lbs.	85	Contact Factory
DC-H4	Heated unit, four wells	66"	36"	36"	4	4000/5000	20.0/22.0	208-230/60/1	396 lbs.	85	Contact Factory
DC-H5	Heated unit, five wells	80"	36"	36"	5	5000/6000	24.0/27.0	208-230/60/1	480 lbs.	85	Contact Factory
DC-H6	Heated unit, six wells	94"	36"	36"	6	6000/7200	29.0/32.0	208-230/60/1	564 lbs.	85	Contact Factory

Concepts Series accessories and modifications can be found on page 72-73.

**Additional Warranties**  
Net Pricing  
Two year parts and labor contract --\$523

# DC-IC: CONCEPTS ICE COOLED SERVING COUNTERS

## DC-MC: CONCEPTS MECHANICALLY COOLED SERVING COUNTERS

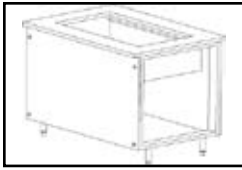

**DC-IC3**

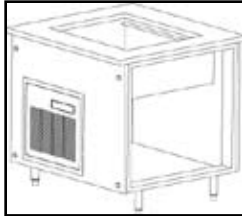

**DC-MC2**

### Product Information

#### DC-IC UNITS ONLY

- NSF-7 certified performance
- Integral V-stamp pan rest
- Heavy duty stainless steel top
- Reinforced stainless steel front and rear removable panels
- Heavy duty base support structure
- Standard on 6" legs
- 1" drain
- Removable perforated false bottom
- High density foamed in place environmentally friendly, Kyoto Protocol Compliant, Non ODP (Ozone Depletion Potential), Non GWP (Global Warming Potential) polyurethane Keeps energy costs low
- One year parts and labor standard warranty

#### DC-MC UNITS ONLY

- NSF-7 certified performance
- Heavy duty stainless steel top
- Reinforced stainless steel front and rear removable panels
- Heavy duty base support structure
- Standard on 6" legs
- Integral V-stamp pan rest
- 1" drain
- Must be fixed hard wired
- High density foamed in place environmentally friendly, Kyoto Protocol Compliant, Non ODP (Ozone Depletion Potential), Non GWP (Global Warming Potential) polyurethane keeps energy costs low
- Environmentally friendly HFC-134A refrigerant
- Thermostat for temperature control
- One year parts and labor standard warranty

### Specifications and Prices

MODEL NUMBER	DESCRIPTION	OVERALL			12"x20" PAN CAP.	SHIP WEIGHT	FREIGHT CLASS	LIST PRICE
		L	D	H				
<b>Ice Cooled serving counters</b>								
DC-IC2	Ice cooled unit, two wells	38"	36"	36"	2	209 lbs.	85	Contact Factory
DC-IC3	Ice cooled unit, three wells	52"	36"	36"	3	286 lbs.	85	Contact Factory
DC-IC4	Ice cooled unit, four wells	66"	36"	36"	4	363 lbs.	85	Contact Factory
DC-IC5	Ice cooled unit, five wells	80"	36"	36"	5	440 lbs.	85	Contact Factory
DC-IC6	Ice cooled unit, six wells	94"	36"	36"	6	517 lbs.	85	Contact Factory

MODEL NUMBER	DESCRIPTION	OVERALL			12"x20" PAN CAP.	H.P.	AMP	BTU LOAD	VOLTS/HERTZ/ PHASE	SHIP WEIGHT	FREIGHT CLASS	LIST PRICE
		L	D	H								
<b>Mechanically cooled counters</b>												
DC-MC2	Mechanically cooled unit, two wells	38"	36"	36"	2	1/5	4.0	379	115/60/1	323 lbs.	85	Contact Factory
DC-MC3	Mechanically cooled unit, three wells	52"	36"	36"	3	1/5	4.0	569	115/60/1	442 lbs.	85	Contact Factory
DC-MC4	Mechanically cooled unit, four wells	66"	36"	36"	4	1/4	7.0	758	115/60/1	561 lbs.	85	Contact Factory
DC-MC5	Mechanically cooled unit, five wells	80"	36"	36"	5	1/4	7.0	948	115/60/1	680 lbs.	85	Contact Factory
DC-MC6	Mechanically cooled unit, six wells	94"	36"	36"	6	1/4	7.0	1138	115/60/1	799 lbs.	85	Contact Factory

#### Additional Warranties

Net Pricing

Two year parts and labor contract --\$523

Five year compressor warranty

1/5 H.P. -----\$108

1/4 H.P. -----\$108

1/3 H.P. -----\$128

Concepts Series accessories and modifications can be found on page 72-73.



# DC-L: CONCEPTS LIQUITEC® SERVING COUNTERS DC-FT: CONCEPTS FROST TOP SERVING COUNTERS

## Product Information

### DC-L UNITS ONLY

- Heavy duty stainless steel top
- Reinforced stainless steel front and rear removable panels
- Heavy duty base support structure
- Standard on 6" legs
- Flush mounted pans
- Individual 0.5" stainless steel drains
- Thermostat for temperature control
- High density foamed in place environmentally friendly, Kyoto Protocol Compliant, Non ODP (Ozone Depletion Potential), Non GWP (Global Warming Potential) polyurethane keeps energy costs low
- Must be hard wired in field
- One year parts and labor standard warranty

### DC-FT UNITS ONLY

- Heavy duty stainless steel top
- Reinforced stainless steel front and rear removable panels
- Heavy duty base support structure
- Standard on 6" legs
- 18-gauge stainless steel one piece construction and perimeter trough
- 0.5" stainless steel drain
- Must be hard wired in field
- One year parts and labor standard warranty

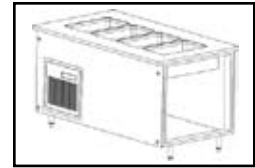

DC-L4



DC-FT6

## Specifications and Prices

MODEL NUMBER	DESCRIPTION	OVERALL			12"x20" PAN CAP.	H.P.	AMP	BTU LOAD	VOLTS/HERTZ/ PHASE	SHIP WEIGHT	FREIGHT CLASS	LIST PRICE
		L	D	H								
<b>LiquiTec® counters</b>												
DC-L2	LiquiTec unit, two wells	38"	36"	36"	2	1/4	7.0	379	115/60/1	342 lbs.	100	Contact Factory
DC-L3	LiquiTec unit, three wells	52"	36"	36"	3	1/4	7.0	569	115/60/1	468 lbs.	100	Contact Factory
DC-L4	LiquiTec unit, four wells	66"	36"	36"	4	1/4	7.0	758	115/60/1	594 lbs.	100	Contact Factory
DC-L5	LiquiTec unit, five wells	80"	36"	36"	5	1/4	7.0	948	115/60/1	720 lbs.	100	Contact Factory
DC-L6	LiquiTec unit, six wells	94"	36"	36"	6	1/4	7.0	1138	115/60/1	846 lbs.	100	Contact Factory

MODEL NUMBER	DESCRIPTION	OVERALL			H.P.	AMP	VOLTS/HERTZ/ PHASE	SHIP WEIGHT	FREIGHT CLASS	LIST PRICE
		L	D	H						
<b>Frost Top counters</b>										
DC-FT2	Frost top unit, 38" length	38"	36"	36"	1/4	7.0	115/60/1	399 lbs.	100	Contact Factory
DC-FT3	Frost top unit, 52" length	52"	36"	36"	1/4	7.0	115/60/1	546 lbs.	100	Contact Factory
DC-FT4	Frost top unit, 66" length	66"	36"	36"	1/4	7.0	115/60/1	693 lbs.	100	Contact Factory
DC-FT5	Frost top unit, 80" length	80"	36"	36"	1/3	8.0	115/60/1	840 lbs.	100	Contact Factory
DC-FT6	Frost top unit, 94" length	94"	36"	36"	1/3	8.0	115/60/1	987 lbs.	100	Contact Factory

Concepts Series accessories and modifications can be found on page 72-73.

**Additional Warranties**  
Net Pricing  
Two year parts and labor contract --\$523  
  
Five year compressor warranty  
1/5 H.P. -----\$108  
1/2 H.P. -----\$139

# DCRU: CONCEPTS RADIAL UTILITY SERVING COUNTERS

## DCRU-H: CONCEPTS RADIAL HEATED SERVING COUNTERS

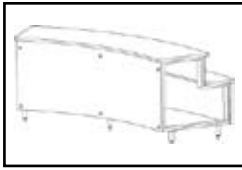

**DCRU-OT**



**DCRU-H3**

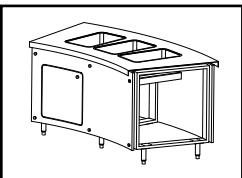

**DCRU-H332**

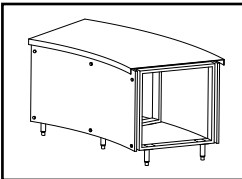

**DCRU-T32**

### Product Information

#### DCRU UTILITY UNITS ONLY

- Heavy duty stainless steel top
- Reinforced stainless steel front and rear removable panels
- Heavy duty base support structure
- Standard on 6" legs
- One year parts and labor standard warranty

- Standard on 6" legs
- Must be fixed hard wired
- 11.87" x 19.87" single hot food wells are manifolded together to one main gate valve
- Wet and dry operation
- Individual infinite temperature controls
- One year parts and labor standard warranty

#### DCRU-H UNITS ONLY

- Flush mount die stamped stainless steel heated food well
- 1/2" stainless steel drains
- Heavy duty stainless steel top
- Reinforced stainless steel front and rear removable panels
- Heavy duty base support structure

### Specifications and Prices

MODEL NUMBER	DESCRIPTION	OVERALL			SHIP WEIGHT	FREIGHT CLASS	LIST PRICE
		L	D	H			
<b>Radial utility serving counters</b>							
DCRU-O	Radial utility base, outside curve	103.3"	36"	36"	464	100	Contact Factory
DCRU-I	Radial utility base inside curve	103.3"	36"	36"	464	100	Contact Factory
DCRU-OT	Radial utility base, outside tiered curve	103.3"	36"	36"	464	100	Contact Factory
DCRU-IT	Radial utility base, inside tiered curve	103.3"	36"	36"	464	100	Contact Factory
DCRU-T25	Radial 25° base	58.4"	36"	36"	270	100	Contact Factory
DCRU-T32	Radial 32° base	75.6"	36"	36"	345	100	Contact Factory
DCRU-T40	Radial 40° base	92.4"	36"	36"	420	100	Contact Factory
DCRUO-TT25	Radial 25° base, tiered outside	58.4"	36"	36"	270	100	Contact Factory
DCRUO-TT32	Radial 32° base, tiered outside	75.6"	36"	36"	354	100	Contact Factory
DCRUO-TT40	Radial 40° base, tiered outside	92.4"	36"	36"	420	100	Contact Factory
DCRUI-TT25	Radial 25° base, tiered inside	58.4"	36"	36"	270	100	Contact Factory
DCRUI-TT32	Radial 32° base, tiered inside	75.6"	36"	36"	345	100	Contact Factory
DCRUI-TT40	Radial 40° base, tiered inside	92.4"	36"	36"	420	100	Contact Factory

MODEL NUMBER	DESCRIPTION	OVERALL			12"x20" PAN CAP.	WATTS	AMP	VOLTS/HERTZ/ PHASE	SHIP WEIGHT	FREIGHT CLASS	LIST PRICE
		L	D	H							
<b>Radial heated serving counters</b>											
DCRU-H2	Radial heated unit, two wells	103.3"	36"	36"	2	2000	16.6	115/60/1	563 lbs.	85	Contact Factory
DCRU-H3	Radial heated unit, three wells	103.3"	36"	36"	3	3000/4000	15.0/16.0	208-230/60/1	604 lbs.	85	Contact Factory
DCRU-H4	Radial heated unit, four wells	103.3"	36"	36"	4	4000/5000	20.0/22.0	208-230/60/1	645 lbs.	85	Contact Factory
DCRU-H5	Radial heated unit, five wells	103.3"	36"	36"	5	5000/6000	24.0/27.0	208-230/60/1	685 lbs.	85	Contact Factory
DCRU-H225	Radius 2 pan hot unit, 25° angle	58.4"	36"	36"	2	2000	16.6	115/60/1	369lbs.	85	Contact Factory
DCRU-H332	Radius 3 pan hot unit, 25° angle	75.6"	36"	36"	3	3000/4000	15.0/16.0	208-230/60/1	485lbs.	85	Contact Factory
DCRU-H440	Radius 4 pan hot unit, 25° angle	92.4"	36"	36"	4	4000/5000	20.0/22.0	208-230/60/1	601lbs.	85	Contact Factory

Concepts Series accessories and modifications can be found on page 72-73.

**Additional Warranties**  
Net Pricing  
Two year parts and labor contract --\$523



# DCRU-IC: CONCEPTS RADIAL ICE COOLED SERVING COUNTERS

## DCRU-MC: CONCEPTS RADIAL MECHANICALLY COOLED SERVING COUNTERS

### Product Information

#### DCRU-IC UNITS ONLY

- Stainless steel pan clip
- Removable perforated false bottom

#### DCRU-MC UNITS ONLY

- Must be fixed hard wired
- Environmentally friendly HFC-134A refrigerant
- Thermostat for temperature control

- High density foamed in place environmentally friendly, Kyoto Protocol Compliant, Non ODP (Ozone Depletion Potential), Non GWP (Global Warming Potential) polyurethane keeps energy costs low
- One year parts and labor standard warranty

#### All Units

- NSF-7 certified performance
- Heavy duty stainless steel top
- Reinforced stainless steel front and rear removable panels
- Heavy duty base support structure
- Standard on 6" legs
- Stainless steel pan clip
- 1" drain

### Specifications and Prices

MODEL NUMBER	DESCRIPTION	OVERALL			12" x 20" PAN CAP.	SHIP WEIGHT	FREIGHT CLASS	LIST PRICE
		L	D	H				
<b>Radial ice cooled serving counters</b>								
DCRU-IC2	Radial ice cooled unit, 36" cold pan	103.3"	36"	36"	2	540 lbs.	85	Contact Factory
DCRU-IC3	Radial ice cooled unit, 50" cold pan	103.3"	36"	36"	3	578 lbs.	85	Contact Factory
DCRU-IC4	Radial ice cooled unit, 60" cold pan	103.3"	36"	36"	4	616 lbs.	85	Contact Factory
DCRU-IC5	Radial ice cooled unit, 74" cold pan	103.3"	36"	36"	5	654 lbs.	85	Contact Factory
DCRU-IC225	Radial ice cooled unit, 25° angle	58.4"	36"	36"	2	540 lbs.	85	Contact Factory
DCRU-IC332	Radial ice cooled unit, 32° angle	75.6"	36"	36"	3	578 lbs.	85	Contact Factory
DCRU-IC440	Radial ice cooled unit, 40° angle	92.4"	36"	36"	4	616 lbs.	85	Contact Factory

MODEL NUMBER	DESCRIPTION	OVERALL			12"x20" PAN CAP.	H.P.	AMP	BTU LOAD	VOLTS/HERTZ/ PHASE	SHIP WEIGHT	FREIGHT CLASS	LIST PRICE
		L	D	H								
<b>Radial mechanically cooled serving counters</b>												
DCRU-MC2	Radial mechanically cooled unit, 36" cold pan	103.3"	36"	36"	2	1/4	7.5	379	115/60/1	604 lbs.	85	Contact Factory
DCRU-MC3	Radial mechanically cooled unit, 50" cold pan	103.3"	36"	36"	3	1/4	7.5	569	115/60/1	644 lbs.	85	Contact Factory
DCRU-MC4	Radial mechanically cooled unit, 60" cold pan	103.3"	36"	36"	4	1/4	7.5	758	115/60/1	684 lbs.	85	Contact Factory
DCRU-MC5	Radial mechanically cooled unit, 74" cold pan	103.3"	36"	36"	5	1/4	7.5	948	115/60/1	724 lbs.	85	Contact Factory
DCRU-MC225	Radial mechanically cooled unit, 25° angle	58.4"	36"	36"	2	1/5	4.0	379	115/60/1	410 lbs.	85	Contact Factory
DCRU-MC332	Radial mechanically cooled unit, 32° angle	75.6"	36"	36"	3	1/5	4.0	569	115/60/1	525 lbs.	85	Contact Factory
DCRU-MC440	Radial mechanically cooled unit, 40° angle	92.4"	36"	36"	4	1/4	7.5	758	115/60/1	640 lbs.	85	Contact Factory

Concepts Series accessories and modifications can be found on page 72-73.



DCRU-IC5



DCRU-MC3

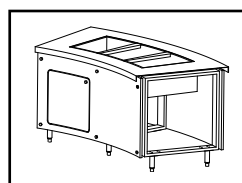

DCRU-IC332

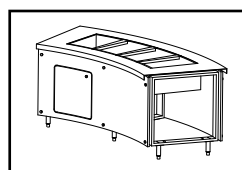

DCRU-MC440

**Additional Warranties**  
 Net Pricing  
 Two year parts and labor contract --\$523  
 Five year compressor warranty  
 1/5 H.P. -----\$108  
 1/4 H.P. -----\$108



# DCRU-L: CONCEPTS LIQUITEC® SERVING COUNTERS

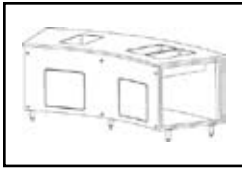

**DCRU-L3**

## Product Information

- Heavy duty stainless steel top
- Reinforced stainless steel front and rear removable panels
- Heavy duty base support structure
- Standard on 6" legs
- Flush mounted pans
- Individual 0.5" stainless steel drains
- Thermostat for temperature control
- High density foamed in place environmentally friendly, Kyoto Protocol Compliant, Non ODP (Ozone Depletion Potential), Non GWP (Global Warming Potential) polyurethane keeps energy costs low
- Must be hard wired in field
- One year parts and labor standard warranty

## Specifications and Prices

MODEL NUMBER	DESCRIPTION	OVERALL			12"x20" PAN CAP.	H.P.	AMP	BTU LOAD	VOLTS/HERTZ/ PHASE	SHIP WEIGHT	FREIGHT CLASS	LIST PRICE
		L	D	H								
<b>LiquiTec® counters</b>												
<b>DCRU-L1</b>	Radial unit with LiquiTec, one pan	103.3"	36"	36"	1	1/4	7.5	292	115/60/1	633 lbs.	100	Contact Factory
<b>DCRU-L2</b>	Radial unit with LiquiTec, two pans	103.3"	36"	36"	2	1/4	7.5	379	115/60/1	679 lbs.	100	Contact Factory
<b>DCRU-L3</b>	Radial unit with LiquiTec, single pan and double pan	103.3"	36"	36"	1&2	1/4	7.5/ 7.5	292/379	115/60/1	848 lbs.	100	Contact Factory
<b>DCRU-L4</b>	Radial unit with LiquiTec, two double pans	103.3"	36"	36"	2&2	1/4	7.5/ 7.5	379/379	115/60/1	897 lbs.	100	Contact Factory

Concepts Series accessories and modifications can be found on page 72-73.

### Additional Warranties

Net Pricing

Two year parts and labor contract --\$523

Five year compressor warranty

1/4 H.P. -----\$108



# DC-T: CONCEPTS TRANSITION SERVING COUNTERS DCRU-T: CONCEPTS RADIAL TRANSITION SERVING COUNTERS

## Product Information

- Heavy duty stainless steel top
- Reinforced stainless steel front and rear removable panels
- Heavy duty base support structure
- Standard on 6" legs
- One year parts and labor standard warranty

## Specifications and Prices

MODEL NUMBER	DESCRIPTION	OVERALL			SHIP WEIGHT	FREIGHT CLASS	LIST PRICE
		L	D	H			
<b>Transition counters</b>							
DC-T22	22 degree transition piece	25.81"	36"	36"	86 lbs.	100	Contact Factory
DC-T45	45 degree transition piece	38.64"	36"	36"	171 lbs.	100	Contact Factory
DC-T90	90 degree transition piece	59.40"	36"	36"	315 lbs.	100	Contact Factory
DC-TT45	45 degree transition piece, tiered	38.64"	36"	36"	171 lbs.	100	Contact Factory
DC-TT90	90 degree transition piece, tiered	59.40"	36"	36"	315 lbs.	100	Contact Factory
<b>Radial transition counters</b>							
DCRU-T22	Radial 22 degree transition piece	18.92"	36"	36"	86 lbs.	100	Contact Factory
DCRU-T45	Radial 45 degree transition piece	37.12"	36"	36"	171 lbs.	100	Contact Factory
DCRU-T90	Radial 90 degree transition piece	68.59"	36"	36"	315 lbs.	100	Contact Factory
DCRU-TT45	Radial 45 degree transition piece, tiered	37.12"	36"	36"	171 lbs.	100	Contact Factory
DCRU-TT90	Radial 90 degree transition piece, tiered	68.59"	36"	36"	315 lbs.	100	Contact Factory

Concepts Series accessories and modifications can be found on page 72-73.



DC-TT45



DCRU-T90

**Additional Warranties**  
Net Pricing  
Two year parts and labor contract --\$523



# DCCS-SD: CONCEPTS SINGLE DRAWER CASH COUNTERS

## DCCS-DD: CONCEPTS DUAL DRAWER CASH COUNTERS

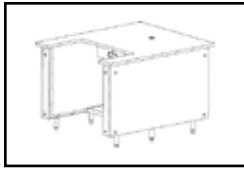

**DCCS-SDW**



**DCCS-DDWR**

### Product Information

- Heavy duty stainless steel top
- Reinforced stainless steel front and rear removable panels
- Heavy duty base support structure
- Standard on 6" legs
- 2" grommet hole in top to allow cord access for cash registers
- Stainless steel locking cash drawer(s) standard
- 120V-15A duplex (GFCI) receptacle, Nema 5-15R 15.0A breaker
- One year parts and labor standard warranty

### Specifications and Prices

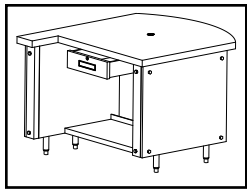

**DCCS-SDRW**

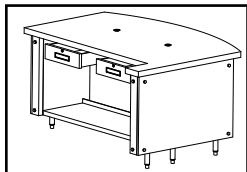

**DCCS-DDRW**

MODEL NUMBER	DESCRIPTION	OVERALL			SHIP WEIGHT	FREIGHT CLASS	LIST PRICE
		L	D	H			
<b>Single drawer cash counters</b>							
<b>DCCS-SD</b>	Single drawer cashier station	45"	36"	36"	270 lbs.	100	Contact Factory
<b>DCCS-SDW</b>	Single drawer cashier station with wing walls	45"	36"	36"	350 lbs.	100	Contact Factory
<b>DCCS-SDWL</b>	Single drawer cashier station with wing wall left	45"	36"	36"	310 lbs.	100	Contact Factory
<b>DCCS-SDWR</b>	Single drawer cashier station with wing wall right	45"	36"	36"	310 lbs.	100	Contact Factory
<b>DCCS-SDR</b>	Single drawer radial cashier station, 48"	48"	36"	36"	310 lbs.	100	Contact Factory
<b>DCCS-SDRW</b>	Single drawer radial cashier station with wing walls, 48"	48"	36"	36"	390 lbs.	100	Contact Factory
<b>DCCS-SDRWL</b>	Single drawer radial cashier station with wing wall left, 48"	48"	36"	36"	350 lbs.	100	Contact Factory
<b>DCCS-SDRWR</b>	Single drawer radial cashier station with wing wall right, 48"	48"	36"	36"	350 lbs.	100	Contact Factory
<b>Dual drawer cash counters</b>							
<b>DCCS-DD</b>	Dual drawer cashier station	72"	36"	36"	540 lbs.	100	Contact Factory
<b>DCCS-DDW</b>	Dual drawer cashier station with wing walls	72"	36"	36"	620 lbs.	100	Contact Factory
<b>DCCS-DDWL</b>	Dual drawer cashier station with wing wall left	72"	36"	36"	580 lbs.	100	Contact Factory
<b>DCCS-DDWR</b>	Dual drawer cashier station with wing wall right	72"	36"	36"	580 lbs.	100	Contact Factory
<b>DCCS-DDR</b>	Dual drawer radial cashier station, 72"	72"	36"	36"	580 lbs.	100	Contact Factory
<b>DCCS-DDRW</b>	Dual drawer radial cashier station with wing walls, 72"	72"	36"	36"	660 lbs.	100	Contact Factory
<b>DCCS-DDRWL</b>	Dual drawer radial cashier station with wing wall left, 72"	72"	36"	36"	620 lbs.	100	Contact Factory
<b>DCCS-DDRWR</b>	Dual drawer radial cashier station with wing wall right, 72"	72"	36"	36"	620 lbs.	100	Contact Factory

Concepts Series accessories and modifications can be found on page 72-73.

**Additional Warranties**  
 Net Pricing  
 Two year parts and labor contract --\$523





# DC-TM: CONCEPTS TOWER END SERVING COUNTERS DCDM: CONCEPTS DISPLAY MERCHANDISER COUNTERS DCHS: CONCEPTS HANDSINK SERVING COUNTERS

## Product Information

### DC-TM

- Heavy duty stainless steel top
- Reinforced stainless steel front and rear removable panels
- Heavy duty base support structure
- Standard on 6" flanged feet, unit must be bolted to the floor
- 36" work height
- Laminated upper
- Removable interior stainless steel panels
- Standard with 5-20 GFCI outlet

### DCDM

- Laminated ends, front, back
- Two removable laminated shelves
- Laminated shelves are adjustable and able to be slanted or flat
- Black poly shelf supports

### DCHS

- Heavy duty stainless steel top
- Reinforced stainless steel front and rear removable panels
- Heavy duty base support structure
- Standard on 6" legs
- 36" work height
- Three sided removable stainless steel riser
- Deck mount faucet
- Finished stainless steel panels
- Soap dispenser
- On board water pump
- On board 2 1/2 gallon water heater
- (2) 5 gallon fresh water containers
- (2) 7 1/2 gallon waste water containers
- Cord and 5-15P plug
- 9" x 14" x 5" sink

### All Units

- One year parts and labor standard warranty

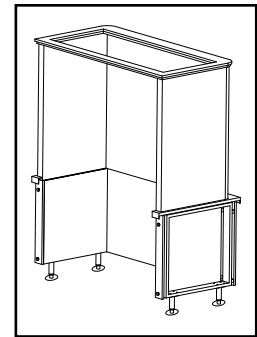

**DCT-66RI**

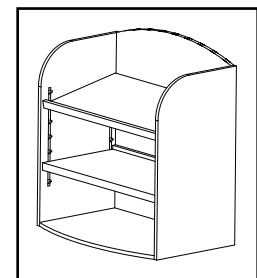

**DCDM-36**

Shown with radial top, and bottom shelf

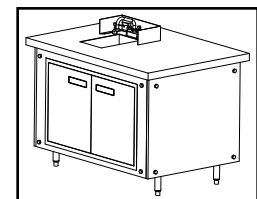

**DCHS-51**

## Specifications and Prices

Model Number	Description	L	D	H	Ship Weight	Freight Class	List price
<b>Tower/End Modules</b>							
DCTM-38RI	Roll in (operator side) tower module 38" length	38"	36"	83.62"	350		Contact Factory
DCTM-66RI	Roll in (operator side) tower module 66" length	66"	36"	83.62"	608		Contact Factory
DCTM-RI	Roll in (operator side) tower module	xx	36"	83.63"	10/inch		Contact Factory
<b>Display Merchandiser</b>							
DCDM-24	Display Merchandiser, Full Front (Customer Self Service)	24"	20"	36"	150		Contact Factory
DCDM-36	Display Merchandiser, Full Front (Customer Self Service)	36"	20"	36"	225		Contact Factory
<b>Handsink</b>							
DCHS-DI	Drop In handsink module	31.13"	28"	22"	220		Contact Factory
DCHS-51	Handsink module	51"	36"	36"	454		Contact Factory

Concepts Series accessories and modifications can be found on page 72-73.

**Additional Warranties**  
Net Pricing  
Two year parts and labor contract --\$523

# DCBU: CONCEPTS RADIAL UTILITY COUNTERS

## DCBC: CONCEPTS RADIAL BEVERAGE COUNTERS

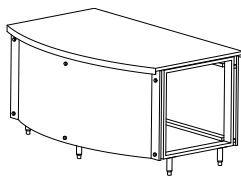

**DCBU-72R**

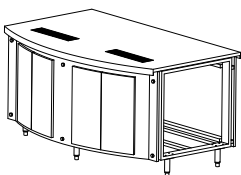

**DCBC-96R**

Shown with optional urn trough

### Product Information

- Heavy duty stainless steel top
- Reinforced stainless steel front and rear removable panels
- Heavy duty base support structure
- Standard on 6" legs
- 36" work height
- One year parts and labor standard warranty

### Specifications and Prices

<i>Model Number</i>	<i>Description</i>	<i>L</i>	<i>D</i>	<i>H</i>	<i>Ship Weight</i>	<i>Freight Class</i>	<i>List price</i>
<b>Radial Front Utility Module</b>							
<b>DCBU-48R</b>	Curved utility module, 48"L	48	44	36	297		<b>Contact Factory</b>
<b>DCBU-72R</b>	Curved utility module, 72"L	72	44	36	360		<b>Contact Factory</b>
<b>DCBU-96R</b>	Curved utility module, 96"L	96	44	36	423		<b>Contact Factory</b>
<b>DCBU-120R</b>	Curved utility module, 120"L	120	44	36	540		<b>Contact Factory</b>
<b>Beverage Counter</b>							
<b>DCBC-48R</b>	Beverage Bar, curved 48" L with hinged locking doors	48	44	36	397		<b>Contact Factory</b>
<b>DCBC-72R</b>	Beverage Bar, curved 72" L with hinged locking doors	72	44	36	460		<b>Contact Factory</b>
<b>DCBC-96R</b>	Beverage Bar, curved 96" L with hinged locking doors	96	44	36	523		<b>Contact Factory</b>
<b>DCBC-120R</b>	Beverage Bar, curved 120" L with hinged locking doors	120	44	36	640		<b>Contact Factory</b>
<b>DCBC-XX</b>	Linear Beverage Bar Module with hinged locking doors	xx	44	36	8/inch		<b>Contact Factory</b>

Concepts Series accessories and modifications can be found on page 72-73.

**Additional Warranties**  
 Net Pricing  
 Two year parts and labor contract --\$523



# N8000-R: DROP-IN CURVED ICE COOLED COLD PAN N8100-BR: DROP-IN CURVED MECHANICALLY COOLED COLD PAN N8700-R: DROP-IN CURVED HEATED ELECTRIC FOOD WELLS

## Product Information

### N8000-R UNITS ONLY

- NSF certified
- A stainless steel holding clip adjusts for pans
- Push-in perimeter gasket
- 1" drain standard
- High density foamed in place environmentally friendly, Kyoto Protocol Compliant, Non ODP (Ozone Depletion Potential), Non GWP (Global Warming Potential) polyurethane keeps energy costs low
- Removable perforated, false bottom
- One year parts and labor standard warranty

### N8100-BR UNITS ONLY

- NSF-7 certified performance
- A stainless steel holding clip adjusts for pans
- High density foamed in place environmentally friendly, Kyoto Protocol Compliant, Non ODP (Ozone Depletion Potential), Non GWP (Global Warming Potential) polyurethane keeps energy costs low
- Push-in perimeter gasket
- Stainless steel louver provided
- Environmentally friendly HFC-134A refrigerant

- 1" drain standard
- Thermostat for temperature control
- One year parts and labor standard warranty

### N8700-R UNITS ONLY

- Top is constructed of 18-gauge stainless steel
- Flush mounted die stamped drawn 12"x20" individual 20-gauge wells
- Wells depressed slightly into the top to hold condensation
- Standard 1/2" stainless steel drain(s)
- Non-marring press fit top gasket
- Must be hard wired in the field
- Wet and dry operation
- 11.87"x19.87" single hot food wells are manifolded together standard to one main gate valve
- Unit shall be insulated on all sides with 1" of fiberglass and bottom to have 2" of fiberfrax blanket insulation
- Individual infinite temperature controls standard wired to one main control panel with 4' of conduit and wire. Field install control panel at location
- Galvanized exterior body
- One year parts and labor standard warranty

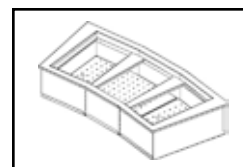

N8059-R

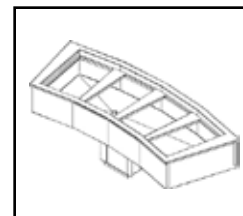

N8176-BR

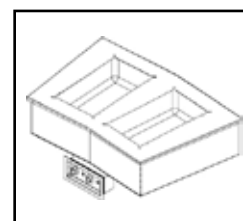

N8744-R

## Specifications and Prices

MODEL NUMBER	L	OVERALL D	H	12"x20" PAN CAP.	SHIP WEIGHT	FREIGHT CLASS	LIST PRICE
<b>Ice cooled curved drop-in</b>							
N8044-R	40.48"	26.05"	10.77"	2	100 lbs.	85	\$2,041
N8059-R	57.22"	26.05"	10.77"	3	118 lbs.	85	\$2,345
N8076-R	73.68"	26.05"	10.77"	4	145 lbs.	85	\$2,739
N8094-R	89.89"	26.05"	10.77"	5	164 lbs.	85	\$3,061

MODEL NUMBER	L	OVERALL D	H	12"x20" PAN CAP.	H.P.	AMP	BTU LOAD	VOLTS/HERTZ/ PHASE	NEMA PLUG	SHIP WEIGHT	FREIGHT CLASS	LIST PRICE
<b>Mechanically cooled curved drop-in</b>												
N8144-BR	40.48"	26.05"	10.77"	2	1/5	4.0	379	115/60/1	5-15P	161 lbs.	85	\$5,231
N8159-BR	57.22"	26.05"	10.77"	3	1/5	4.0	569	115/60/1	5-15P	184 lbs.	85	\$5,971
N8176-BR	73.68"	26.05"	10.77"	4	1/4	7.0	758	115/60/1	5-15P	233 lbs.	85	\$6,416
N8194-BR	89.89"	26.05"	10.77"	5	1/4	7.0	948	115/60/1	5-15P	243 lbs.	85	\$6,976

MODEL NUMBER	L	OVERALL D	H	12"x20" PAN CAP.	AMP	WATTS	VOLTS/HERTZ/ PHASE	SHIP WEIGHT	FREIGHT CLASS	LIST PRICE
<b>Heated curved drop ins</b>										
N8744-R	40.48"	26.05"	9.08"	2	16.6	2000	120/60/1	99 lbs.	85	\$3,252
N8759-R	57.22"	26.05"	9.08"	3	15.0/16.0	3000/4000	208-230/60/1	134 lbs.	85	\$4,606
N8776-R	73.68"	26.05"	9.08"	4	20.0/22.0	4000/4800	208-230/60/1	166 lbs.	85	\$5,989
N8794-R	89.80"	26.05"	9.08"	5	24.0/27.0	5000/6000	208-230/60/1	186 lbs.	85	\$7,368

### Additional Warranties

Net Pricing

Two year parts and labor contract --\$523

Five year compressor warranty

1/5 H.P. -----\$108

1/4 H.P. -----\$108

## Trayslides

<b>DCTS-SV</b> Stainless Steel "V" Tray Slide.....	Contact Factory
<b>DCTS-3B</b> 3-Bar S/S Tray Slide.....	Contact Factory
<b>DCTS-3BR</b> 3-Bar radial S/S Tray Slide.....	Contact Factory
<b>DCTS-SS</b> Solid Surface Tray Slide .....	Contact Factory
<b>DCTS-SSR</b> Solid Surface Tray Slide, with s/s runners .....	Contact Factory
<b>DCTS-SSE</b> Solid Surface Extension as Tray Slide with s/s runners .....	Contact Factory
<b>DCTS-GT</b> Granite Top Extension as Tray Slide .....	Contact Factory
<b>DCTS-GTR</b> Granite Top Extension as Tray Slide, with s/s runners .....	Contact Factory
<b>DCTSF-3B-22</b> 3 Bar 22 degree corner filler tray slide .....	Contact Factory
<b>DCTSF-3B-25</b> 3 Bar 25 degree corner filler tray slide .....	Contact Factory
<b>DCTSF-3B-32</b> 3 Bar 32 degree corner filler tray slide .....	Contact Factory
<b>DCTSF-3B-40</b> 3 Bar 40 degree corner filler tray slide .....	Contact Factory
<b>DCTSF-3B-45</b> 3 Bar 45 degree corner filler tray slide .....	Contact Factory
<b>DCTSF-3B-90</b> 3 Bar 90 degree corner filler tray slide .....	Contact Factory
<b>DCTSF-SS-22</b> Solid Surface 22 degree corner filler tray slide .....	Contact Factory
<b>DCTSF-SS-25</b> Solid Surface 25 degree corner filler tray slide .....	Contact Factory
<b>DCTSF-SS-32</b> Solid Surface 32 degree corner filler tray slide .....	Contact Factory
<b>DCTSF-SS-40</b> Solid Surface 40 degree corner filler tray slide .....	Contact Factory
<b>DCTSF-SS-45</b> Solid Surface 45 degree corner filler tray slide .....	Contact Factory
<b>DCTSF-SS-90</b> Solid Surface 90 degree corner filler tray slide .....	Contact Factory

## Workshelves

<b>DCWS-10</b> 10" stainless steel workshelf .....	Contact Factory
<b>DCWS-12</b> 12" stainless steel workshelf .....	Contact Factory

## Base Finishes

<b>DCSE</b> S/S Finished End Panel.....	Contact Factory
<b>DCLE</b> Laminate End Panel.....	Contact Factory
<b>DCLF</b> Laminate Front Panel, Standard laminates (Wilsonart, Nevamar, Formica and Pionite) .....	N/C
<b>DCLB</b> Laminate Back Panel, Standard laminates (Wilsonart, Nevamar, Formica and Pionite) .....	N/C
<b>DCLFC</b> Laminate Front Panel, Custom laminates (any metallics, Chemetal) .....	Contact Factory
<b>DCLBC</b> Laminate Back Panel, Custom laminates (any metallics, Chemetal) .....	Contact Factory
<b>DCKP</b> S/S or Laminated kick plate .....	Contact Factory
<b>DCKPR</b> S/S or Laminated kick plate return.....	Contact Factory

## Top Materials

<b>DCTG</b> Granite Top Material.....	Contact Factory
<b>DCTH</b> Hanstone Top Material .....	Contact Factory
<b>DCTC</b> Corian Top Material .....	Contact Factory
<b>DCTA</b> Avonite Top Material .....	Contact Factory
<b>DCTD</b> Diamond Top Material.....	Contact Factory
<b>DCTM</b> Solid Surface Top Material - TBD.....	Contact Factory

## Top/Base Accessories

<b>DCC</b> Casters in lieu of Legs.....	Contact Factory
<b>DCTC</b> Top Cutouts.....	Contact Factory
<b>DCBS</b> Stainless steel backsplash.....	Contact Factory
<b>DCBSR</b> Stainless steel backsplash return .....	Contact Factory
<b>DCSSBS</b> Solid surface backsplash.....	Contact Factory
<b>DCSSBSR</b> Solid surface backsplash return .....	Contact Factory
<b>DCDP</b> Décor Panels .....	Contact Factory
<b>DCPGDP</b> Colored Plexiglas stand off decor panel.....	Contact Factory
<b>DCPGDPG</b> Plexiglas stand off decor panel with graphic .....	Contact Factory
<b>DCPGLP</b> Plexiglas laminated stand off décor panel .....	Contact Factory
<b>DCBLP</b> LED ligh panel for Décor Panel .....	Contact Factory
<b>DCPSL26</b> Builtin plate shelf linear 26" (2-pan) .....	Contact Factory
<b>DCPSL42</b> Builtin plate shelf linear 42" (3-pan) .....	Contact Factory
<b>DCPSL56</b> Builtin plate shelf linear 56" (4-pan) .....	Contact Factory
<b>DCPSRO</b> Builtin plate shelf radial outside 42" .....	Contact Factory
<b>DCPSRI</b> Builtin plate shelf radial inside 32" .....	Contact Factory
<b>DCGS</b> Subtop in lieu of stainless stell top .....	Contact Factory
<b>DCLED</b> LED under nosing lighting .....	Contact Factory
<b>DCFF</b> Manual Fill Faucet .....	Contact Factory
<b>DCFH</b> 2" Ferruled Hole .....	Contact Factory
<b>DCGH</b> 3" Grommeted Hole .....	Contact Factory
<b>DCEO</b> 115V/15A Outlet with 10amp Breaker .....	Contact Factory
<b>DCDO</b> Deck Mount Outlets .....	Contact Factory
<b>DCC</b> Casters in lieu of Legs .....	Contact Factory
<b>DCCO</b> Top Cutouts .....	Contact Factory
<b>DCBPA</b> 100-200 amp panel box (cost of housing not included) .....	Contact Factory
<b>DCBPB</b> Circuit-non-ground fault (includes breaker, conduit, wire) .....	Contact Factory
<b>DCBPC</b> Circuit-ground fault .....	Contact Factory
<b>DCLRI</b> Linear Roll-In Section .....	Contact Factory

## Base Inserts/Doors

<b>DCOS-12</b> Openshelf Insert, 9" high .....	Contact Factory
<b>DCOS-18</b> Openshelf Insert, 9" high .....	Contact Factory
<b>DCOS-24</b> Openshelf Insert, 9" high .....	Contact Factory
<b>DCOS-36</b> Openshelf Insert, 9" high .....	Contact Factory
<b>DCOS-48</b> Openshelf Insert, 9" high .....	Contact Factory
<b>DCOS-H12</b> Openshelf Insert, 15" high .....	Contact Factory
<b>DCOS-H18</b> Openshelf Insert, 15" high .....	Contact Factory
<b>DCOS-H24</b> Openshelf Insert, 15" high .....	Contact Factory
<b>DCOS-H36</b> Openshelf Insert, 15" high .....	Contact Factory
<b>DCOS-H48</b> Openshelf Insert, 15" high .....	Contact Factory
<b>DCID</b> Inlay Access Door .....	Contact Factory
<b>DCSD-36</b> Sliding Door Insert.....	Contact Factory
<b>DCSD-48</b> Sliding Door Insert.....	Contact Factory
<b>DCDS-S18</b> Single Door Dry Storage Insert.....	Contact Factory
<b>DCDS-S24</b> Single Door Dry Storage Insert.....	Contact Factory
<b>DCDS-D36</b> Double Door Dry Storage Insert.....	Contact Factory
<b>DCDS-D48</b> Double Door Dry Storage Insert.....	Contact Factory
<b>DCMA-S</b> Single Mechanical Access Door .....	Contact Factory
<b>DCMA-D</b> Double Mechanical Access Doors.....	Contact Factory
<b>DCMA-L</b> Louvered Mechanical Access Door.....	Contact Factory
<b>DCRI</b> Refrigerated Base Insert .....	Contact Factory
<b>DCHI-S</b> Single Section Heated Base Insert .....	Contact Factory
<b>DCHI-D</b> Double Section Heated Base Insert .....	Contact Factory

**Heated Black Glass Shelf (HBGB)**

<b>DCBH-24</b> 24" Heated Black Glass Surface .....	Contact Factory
<b>DCBH-30</b> 30" Heated Black Glass Surface .....	Contact Factory
<b>DCBH-36</b> 36" Heated Black Glass Surface .....	Contact Factory
<b>DCBH-48</b> 48" Heated Black Glass Surface .....	Contact Factory
<b>DCBH-60</b> 60" Heated Black Glass Surface .....	Contact Factory
<b>DCBH-72</b> 72" Heated Black Glass Surface .....	Contact Factory

**Heated Stone surface (GRSSB)**

<b>DCHS-24</b> 24" Heated Stone surface .....	Contact Factory
<b>DCHS-30</b> 30" Heated Stone surface .....	Contact Factory
<b>DCHS-36</b> 36" Heated Stone surface .....	Contact Factory
<b>DCHS-48</b> 48" Heated Stone surface .....	Contact Factory
<b>DCHS-60</b> 60" Heated Stone surface .....	Contact Factory
<b>DCHS-72</b> 72" Heated Stone surface .....	Contact Factory

Colors Available: Gray Granite, Bermuda Sand, Night Sky, Sawgrass

**Tower Upper Structure options**

<b>DCDEB</b> Dry erase board.....	Contact Factory
<b>DCSBG</b> Sintra board with graphics.....	Contact Factory
<b>DCFPMB</b> Non-Illuminated Flexcover panel menu board.....	Contact Factory
<b>DCMB</b> Non-Illuminated menu board .....	Contact Factory
<b>DCLCDB32</b> LCD Menu board - 32".....	Contact Factory
<b>DCLCDB42</b> LCD Menu board - 42".....	Contact Factory
<b>DCTL2</b> Directional lighting (track lighting w/ black gooseneck lights ) - 2 lights .....	Contact Factory
<b>DCTL3</b> Directional lighting (track lighting w/ black gooseneck lights ) - 3 lights .....	Contact Factory
<b>DCUSGP</b> Graphic package.....	Contact Factory
<b>DCUPO</b> Interior outlet options for roll-in units .....	Contact Factory

**Display Case Module**

<b>DCDCGP</b> Graphic package .....	Contact Factory
<b>DCDCTGS</b> Tempered glass shelves in lieu of laminated shelves	Contact Factory
<b>DCDCRB</b> Radial front on bottom laminated shelf .....	Contact Factory
<b>DCDCRT</b> Radial top .....	Contact Factory
<b>DCDCWPS</b> White poly shelf supports .....	Contact Factory

**Hand Sink Module**

<b>DCPTH</b> Paper towel holder - Bobrick Model B26212.....	Contact Factory
---	-----------------

**Radial Front Utility Module & Beverage Counter**

<b>DCBCTM-12</b> Beverage Bar, Tower Module Accessory .....	Contact Factory
<b>DCBS</b> Backsplash .....	Contact Factory
<b>DCBSRL</b> Backsplash Return left .....	Contact Factory
<b>DCBSRR</b> Backsplash Return right.....	Contact Factory
<b>DCT</b> Tower module.....	Contact Factory
<b>DCTRHD</b> Hinged door internal access to waste receptacle .....	Contact Factory
<b>DCTRC</b> Round top cutout with 16" x 11" x 20" tall waste receptacle.....	Contact Factory
<b>DCTRCB</b> Round cutout in base .....	Contact Factory
<b>DCCD</b> Cup dispenser.....	Contact Factory
<b>DCLO</b> Lid organizer .....	Contact Factory
<b>DCSO</b> Straw organizer.....	Contact Factory
<b>DCND</b> Napkin dispensers for standard napkin: full fold, 4-1/2" x 5" - 6-1/2" .....	Contact Factory
<b>DCSD</b> Soufflé' cup dispensers - Dispense-Rite for ¾ to 2-1/2 oz. portions.....	Contact Factory
<b>DCCP</b> Condiment pump.....	Contact Factory
<b>DCOU</b> Open shelf understorage.....	Contact Factory
<b>DCOUI</b> Open shelf understorage with intermediate shelf.....	Contact Factory
<b>DCLHD</b> Locking full height hinged door dry base fronts.....	Contact Factory
<b>DCDW</b> Dry storage well - 12" x 20" x 6-1/2" deep .....	Contact Factory

**Cashier Counter Accessories**

<b>DCCPU45</b> CPU housing - 45"L Base .....	Contact Factory
<b>DCCPU72</b> CPU housing - 72"L Base .....	Contact Factory
<b>DCFRS</b> s/s dia. foot rest with shelf .....	Contact Factory
<b>DCFR</b> s/s dia. foot rest without shelf.....	Contact Factory
<b>DCPOS</b> Pull out shelf in base.....	Contact Factory

**Signage/Overstructures**

<b>DCOA-XX</b> Adjustable Height Overstructure with Vertical Signage Board with graphic .....	Contact Factory
<b>DCOF-XX</b> Fixed Height Overstructure with Vertical Signage Board with graphic .....	Contact Factory
<b>DCOW-XX</b> Wall Mount Overstructure with Vertical Signage Board with graphic .....	Contact Factory
<b>DCORF</b> Radial Fixed Height Overstructure with Vertical Radial Signage Board with graphic, Radial base.....	Contact Factory
<b>DCORA</b> Radial Adjustable Height Overstructure with Vertical Radial Signage Board with graphic, Radial base.....	Contact Factory
<b>DCORFT</b> Radial Fixed Height Overstructure with Vertical Radial Signage Board with graphic, 90° base.....	Contact Factory
<b>DCORAT</b> Radial Adjustable Height Overstructure with Vertical Radial Signage Board with graphic, 90° base.....	Contact Factory
<b>DCCOP</b> Custom Powdercoat for Overstructure .....	Contact Factory
<b>DCSDS</b> Dual Sided Signage.....	Contact Factory
<b>DCSAD</b> Signage Angled Down .....	Contact Factory
<b>DCSAU</b> Signage Angled Up.....	Contact Factory
<b>DCSPTF</b> Perforated Horizontal Top, Flat .....	Contact Factory
<b>DCSPTU</b> Perforated Horizontal Top, Arched Up .....	Contact Factory
<b>DCSPTD</b> Perforated Horizontal Top, Arched Down .....	Contact Factory
<b>DCSRT</b> Signage Removable with Thumbscrews .....	Contact Factory
<b>DCSP</b> Powdercoated Vertical Signage Board with graphic in lieu of standard .....	Contact Factory
<b>DCSPA</b> Perforated Powdercoated Aluminum Vertical Signage Backer (in lieu of Standard Signage Board and graphic) .....	N/C
<b>DCSSR</b> Shaped Signage with Backer, Round with Laminate or Graphic.....	Contact Factory
<b>DCSSO</b> Shaped Signage with Backer, Oval with Laminate or Graphic.....	Contact Factory
<b>DCSST</b> Shaped Signage with Backer, Triangle with Laminate or Graphic .....	Contact Factory
<b>DCSSS</b> Shaped Signage with Backer, Square with Laminate or Graphic.....	Contact Factory
<b>DCCA-XX</b> Adjustable Height Canopy with Graphics.....	Contact Factory
<b>DCCF-XX</b> Fixed Height Canopy with Graphics .....	Contact Factory
<b>DCCW-XX</b> Wall Mount Canopy with Graphics.....	Contact Factory
<b>DCDL</b> Décor Heat Lamp.....	Contact Factory
<b>DCGL</b> Gooseneck Light .....	Contact Factory

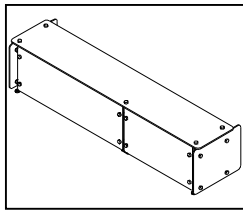

**DCFSG**

Single tier glass front protector

## Product Information

- Mostly glass display allows you to see product from every angle
- Standard construction is 1" diameter stainless steel tubular legs. 1/4" tempered glass fronts and end glass. 3/8" tempered glass top shelf
- Comes fully assembled
- Standard bright chrome finish and black powdercoat
- End glass is standard on all food shields
- A complete line of accessories including stainless steel shelves, heat lamps and lighting
- All models meet NSF 2011 requirements.

## Specifications and Prices

Model Number	Description	Per Linear Inch Pricing
DCFSG	Glass front food shield, single tier with glass shelf, single service	\$119
DCFSG2	Glass front food shield, double tier with two glass shelves, single service	\$179
DCFSSS	Glass front food shield, slicer shield style	\$63
DCFSH	Two tier display, sneeze guard, single service	\$170
DCFSHD	Two tier display with sneeze guard, dual service	\$244
DCFSFS	Flexible shield, converts to three positions	\$143
DCFSFS2	Flexible shield, converts to three positions, two tier	\$215
DCFSKS	Single tier display, fixed sneeze guard front, single service	\$108
DCFSKD	Single tier display, fixed sneeze guard front, dual service	\$147
DCFSGH	Double tier display, bottom tier full glass front, second tier sneeze guard	\$185
DCFSHG	Double tier display, bottom tier sneeze guard, second tier full glass front	\$185

Model Number	Description	L	W	H	List Price
<b>Flexishield Display</b>					
DCFSRCR	Corner Flexishield, 24" 90 degree with radius front edge, single tier	24.00	24.00	16.00	\$2,955
DCFSRCD	Corner Flexishield, 24" 90 degree with radius front edge, double tier	24.00	24.00	26.00	\$5,909
DCFSOS-XX	Overshelf with radial front edge, single tier	xx	18.00	16.00	\$59
DCFSOS2-XX	Overshelf with radial front edge, double tier	xx	18.00	26.00	\$119

### Accessory Options

	Per Linear Inch
DCFSFL	Fluorescent light with on/off switch .....\$26
DCFHL	Radiant heat lamp with switch .....\$30
DCFSSL	Slim line heat lamps with on/off switch .....\$30
DCFSHEL	Stainless steel shelf .....N/C
DCFSLED	LED light .....\$25

### Black Powdercoating

DCFSBP-G	G Style food shield .....\$18
DCFSBP-G2	G2 Style food shield .....\$27
DCFSBP-SS	SS Style food shield .....\$9
DCFSBP-H	H Style food shield .....\$25
DCFSBP-HD	HD Style food shield .....\$37
DCFSBP-FS	FS Style food shield .....\$21
DCFSBP-FS2	FS2 Style food shield .....\$33
DCFSBP-KD	KD Style food shield .....\$22
DCFSBP-KS	KS Style food shield .....\$17
DCFSBP-GH	GH Style food shield .....\$27
DCFSBP-HG	HG Style food shield .....\$27



# DCFSR: RADIAL FLEXISHIELD® FOOD SHIELD

## Product Information

- Mostly glass display allows you to see product from every angle
- 1" stainless steel legs
- Meets 2011 NSF requirements
- Flange mounted foot makes installation easy
- Comes fully assembled from factory
- Standard end glass
- One year parts and labor standard warranty

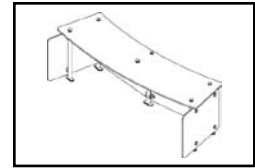

DCFSRIG-3

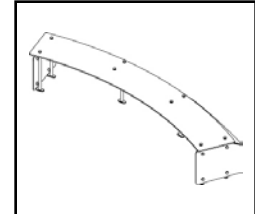

DCFSROKS-5

## Specifications and Prices

MODEL NUMBER	DESCRIPTION	OVERALL			SHIP WEIGHT	FREIGHT CLASS	LIST PRICE
		L	D	H			
<b>Radial FlexiShield foodshields</b>							
DCFSRIG-2	Radial food shield, full glass front, inside, single service, 2 pan	38.47"	18"	16"	Contact factory	Contact factory	\$8,404
DCFSRIG-3	Radial food shield, full glass front, inside, single service, 3 pan	53.43"	18"	16"	Contact factory	Contact factory	\$9,829
DCFSRIG-4	Radial food shield, full glass front, inside, single service, 4 pan	68.17"	18"	16"	Contact factory	Contact factory	\$11,254
DCFSRIG-5	Radial food shield, full glass front, inside single service 5 pan	82.61"	18"	16"	Contact factory	Contact factory	\$12,678
DCFSROG-2	Radial food shield, full glass front, outside, single service, 2 pan	43.09"	18"	16"	Contact factory	Contact factory	\$8,635
DCFSROG-3	Radial food shield, full glass front, outside, single service, 3 pan	59.85"	18"	16"	Contact factory	Contact factory	\$10,056
DCFSROG-4	Radial food shield, full glass front, outside, single service, 4 pan	76.35"	18"	16"	Contact factory	Contact factory	\$11,477
DCFSROG-5	Radial food shield, full glass front, outside single service 5 pan	92.53"	18"	16"	Contact factory	Contact factory	\$12,896
DCFSRIKS-2	Radial food shield, sneeze guard front, inside, single service, 2 pan	38.47"	18"	14.75"	Contact factory	Contact factory	\$8,161
DCFSRIKS-3	Radial food shield, sneeze guard front, inside, single service, 3 pan	53.43"	18"	14.75"	Contact factory	Contact factory	\$9,690
DCFSRIKS-4	Radial food shield, sneeze guard front, inside, single service, 4 pan	68.17"	18"	14.75"	Contact factory	Contact factory	\$11,220
DCFSRIKS-5	Radial food shield, sneeze guard front, inside single service 5 pan	82.61"	18"	14.75"	Contact factory	Contact factory	\$12,750
DCFSROKS-2	Radial food shield, sneeze guard front, outside, single service, 2 pan	43.09"	18"	14.75"	Contact factory	Contact factory	\$8,297
DCFSROKS-3	Radial food shield, sneeze guard front, outside, single service, 3 pan	59.85"	18"	14.75"	Contact factory	Contact factory	\$9,824
DCFSROKS-4	Radial food shield, sneeze guard front, outside, single service, 4 pan	76.35"	18"	14.75"	Contact factory	Contact factory	\$11,351
DCFSROKS-5	Radial food shield, sneeze guard front, outside single service 5 pan	92.53"	18"	14.75"	Contact factory	Contact factory	\$12,876
DCFSRKD-2	Radial food shield, sneeze guard front, dual service, 2 pan	43.09"	35.50"	15"	Contact factory	Contact factory	\$13,298
DCFSRKD-3	Radial food shield, sneeze guard front, dual service, 3 pan	59.85"	35.50"	15"	Contact factory	Contact factory	\$16,084
DCFSRKD-4	Radial food shield, sneeze guard front, dual service, 4 pan	76.35"	35.50"	15"	Contact factory	Contact factory	\$18,870
DCFSRKD-5	Radial food shield, sneeze guard front, dual service 5 pan	92.53"	35.50"	15"	Contact factory	Contact factory	\$21,655

## Flexishield® Powdercoat

### Black Powdercoat

DCFSBP-RIG-2 RIG-2 style radial food shield .....	\$725	DCFSBP-RIKS-4 RIKS-4 style radial food shield .....	\$1,189
DCFSBP-RIG-3 RIG-3 style radial food shield .....	\$1,076	DCFSBP-RIKS-5 RIKS-5 style radial food shield .....	\$1,450
DCFSBP-RIG-4 RIG-4 style radial food shield .....	\$1,262	DCFSBP-ROKS-2 ROKS-2 style radial food shield .....	\$681
DCFSBP-RIG-5 RIG-5 style radial food shield .....	\$1,540	DCFSBP-ROKS-3 ROKS-3 style radial food shield .....	\$1,013
DCFSBP-ROG-2 ROG-2 style radial food shield .....	\$725	DCFSBP-ROKS-4 ROKS-4 style radial food shield .....	\$1,189
DCFSBP-ROG-3 ROG-3 style radial food shield .....	\$1,076	DCFSBP-ROKS-5 ROKS-5 style radial food shield .....	\$1,450
DCFSBP-ROG-4 ROG-4 style radial food shield .....	\$1,262	DCFSBP-RKD-2 RKD-2 style radial food shield .....	\$895
DCFSBP-ROG-5 ROG-5 style radial food shield .....	\$1,540	DCFSBP-RKD-3 RKD-3 style radial food shield .....	\$1,330
DCFSBP-RIKS-2 RIKS-2 style radial food shield .....	\$681	DCFSBP-RKD-4 RKD-4 style radial food shield .....	\$1,559
DCFSBP-RIKS-3 RIKS-3 style radial food shield .....	\$1,013	DCFSBP-RKD-5 RKD-5 style radial food shield .....	\$1,904

DELFIELD FLEXISHIELD® FOOD SHIELDS

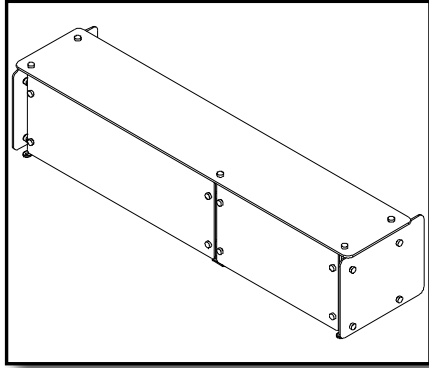

**DCFSG Series**  
Single tier glass front protector

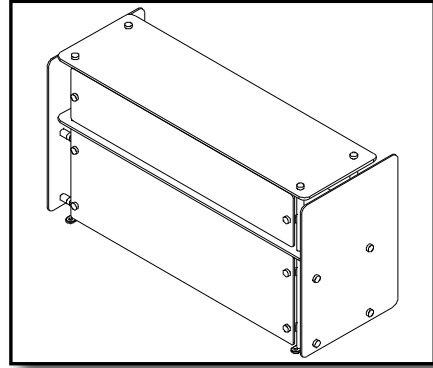

**DCFSG2 Series**  
Double tier glass front protector

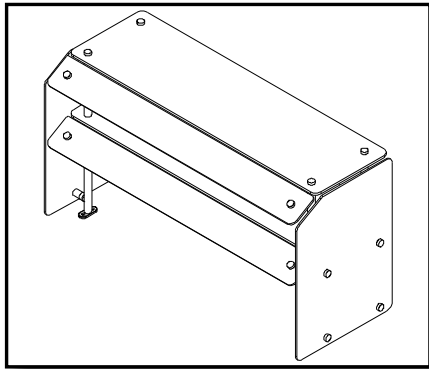

**DCFSH Series**  
Double tier, with sneeze guard fronts

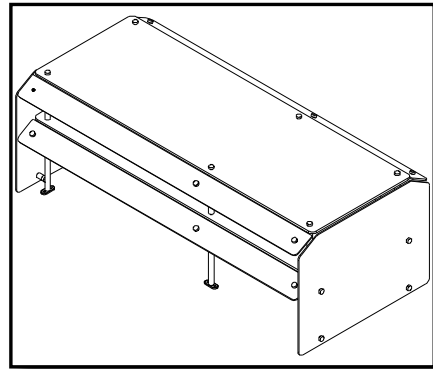

**DCFSHD Series**  
Double service, double tier display with sneeze guard fronts

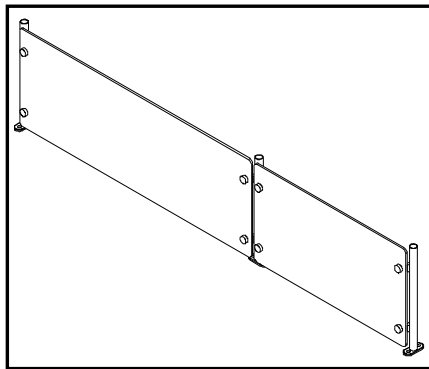

**DCFSSS Series**  
Slicer Shield

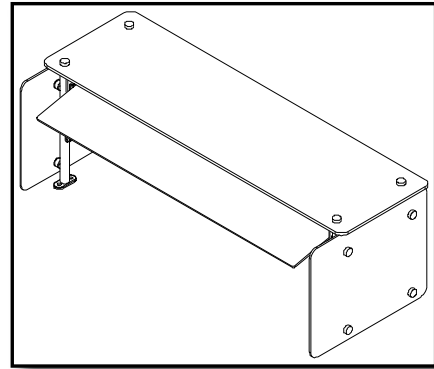

**DCFSFS Series**  
Single tier, flexible food shield (pivots in three positions)



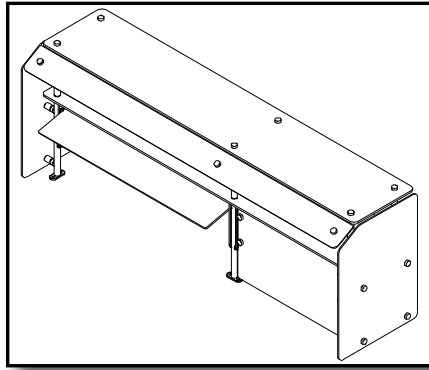

**DCFSFS2 Series**  
Double tier flexible foodshield (pivots in three positions)

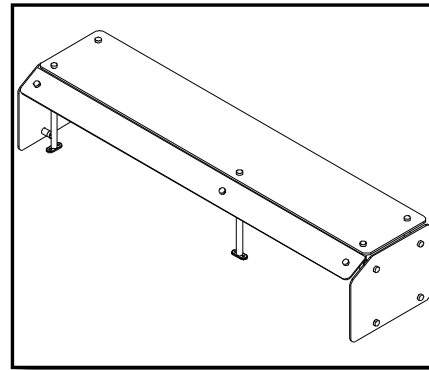

**DCFSKS Series**  
Single tier, fixed food shield front, single service

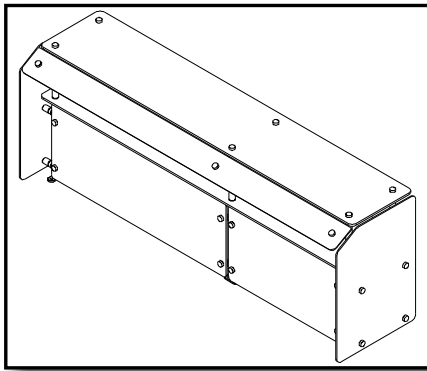

**DCFSGH Series**  
Double tier display, bottom tier full glass front, second tier sneezeguard style

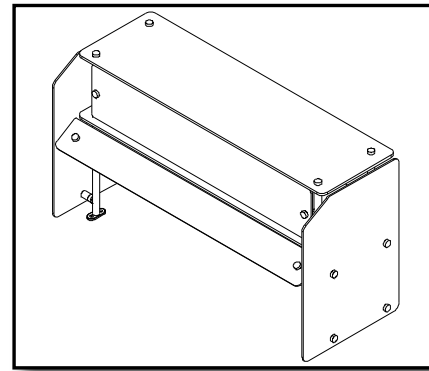

**DCFSHG Series**  
Double tier display bottom tier sneezeguard style, second tier full glass front

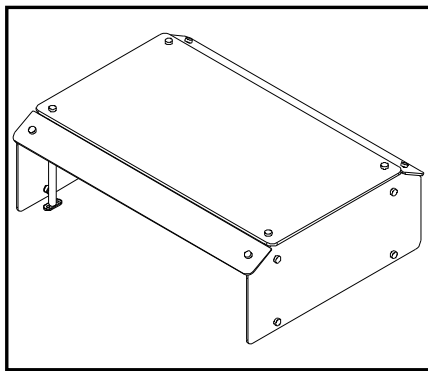

**DCFSKD Series**  
Single tier, fixed food shield front, dual service

# SE-H/SES-H SERIES - HEATED SERVING COUNTERS

## SE-C/SES-C SERIES - COLD PAN SERVING COUNTERS



**SE-H3**

Shown with optional ABS panels

### Product Information

- SE-H and SES-H Series counters are standard with 12" x 20" x 6" deep stainless steel heated food wells, cord and plug, and 5" diameter swivel, locking casters. (Note: when lights are used over the hot wells, incandescent lights will be used due to heat.)
- 16 gauge stainless steel tops.
- SE-H and SES-H models are standard with Delfield's exclusive Delrite™ ABS or reversible laminated modesty panels in front and ends of unit.
- Black laminate backs each modesty panel.
- Units are standard with drain and gate valve.
- All electrical connections are 60 hertz, single phase. Electrical accessories may change listed amperage and plug
- SES-H models are 30" high overall
- SE-H models are 36" high overall
- One year parts and 90 day labor standard warranty. Additional warranties available, see below

Choose from Laminate or Delfield's exclusive Delrite™ ABS panels. ABS panels are available in black & light blue. Contact Delfield for a color chart or visit [www.delfield.com](http://www.delfield.com).

### Specifications and Prices

MODEL NUMBER	DESCRIPTION	OVERALL			AMP	VOLTS	WATTS	NEMA PLUG	SHIP WEIGHT	FREIGHT CLASS	LIST PRICE
		L	D	H							
<b>SHELLEYBASIC HEATED COUNTERS</b>											
SE-H2	2 food wells	39"	29"	36"	10.0/11.0	120/208-230	2000/2400	14-20P	215	100	\$4,868
SE-H3	3 food wells	50"	29"	36"	15.0/16.0	120/208-230	3000/3600	14-20P	265	100	\$5,600
SE-H4	4 food wells	64"	29"	36"	20.0/22.0	120/208-230	4000/4800	14-30P	320	100	\$6,256
SE-H5	5 food wells	78"	29"	36"	24.0/27.0	120/208-230	5000/6000	14-50P	410	100	\$7,151
SE-H6	6 food wells	92"	29"	36"	29.0/32.0	120/208-230	6000/7000	14-50P	500	100	\$8,066

Add S for 30" high models. (Example SES-H)



**SE-C3**

Shown with ABS side panels, melamine front and optional trayslide

### Product Information

- SE-C and SES-C Series counters are standard with 9" deep stainless steel Bloomington style cold pan (recessed 2", accomodates 6" deep pans), condensing unit, drain with valve, cord and plug and 5" swivel, locking casters
- 16 gauge stainless steel tops.
- SE-C and SES-C are open on the operator's side, furnished with a full bottom stainless steel shelf.
- SE-C and SES-C models are standard with Delfield's exclusive Delrite™ ABS or reversible laminated modesty panels in front and ends of unit.
- Black laminate backs each modesty panel.
- Electrical accessories may change listed amperage and plug
- SES-C models are 30" high overall
- SE-C models are 36" high overall
- One year parts and 90 day labor standard warranty. Additional warranties available, see below.

### Specifications and Prices

MODEL NUMBER	12 X 20 X 4 PANS HELD	OVERALL			H.P.	AMP	VOLTS	NEMA PLUG	SHIP WEIGHT	FREIGHT CLASS	LIST PRICE
		L	D	H							
<b>SHELLEYBASIC REFRIGERATED COLD PAN SERVING COUNTERS</b>											
SE-C2	2	39"	29"	36"	1/5	4.0	115	5-15P	340	100	\$7,489
SE-C3	3	50"	29"	36"	1/5	4.0	115	5-15P	415	100	\$7,804
SE-C4	4	64"	29"	36"	1/4	7.0	115	5-15P	490	100	\$8,066
SE-C5	5	78"	29"	36"	1/4	7.0	115	5-15P	565	100	\$8,846
SE-C6	6	92"	29"	36"	1/3	7.0	115	5-15P	640	100	\$10,177

Add S for 30" high models. (Example SES-C)

Shelleybasic accessories and modifications can be found on pages 83-86.

### Additional Warranties

Net Pricing  
 One year parts and labor contract --- \$279  
 Two year parts and labor contract --- \$523  
 Five year compressor warranty  
 1/5 H.P. ----- \$108  
 1/4 H.P. ----- \$108  
 1/3 H.P. ----- \$128



# SE-HC/SES-HC SERIES - HOT/COLD COMBINATION SERVING COUNTERS

## SE-I/SES-I SERIES - ICE COOLED SERVING COUNTERS

**Shelleybasic**<sup>®</sup>  
by Delfield



**SE-HC3**

Shown with option SE-KS single service buffet shield

### Product Information

- SE-HC and SES-HC Series counters are standard with single 8" deep stainless steel food tank (which can be switched from heated to chilled operation with the flip of a switch), condensing unit, drain with valve, cord and plug, and 5" swivel, locking casters
- 16 gauge stainless steel tops.
- SE-HC and SES-HC units are open on the operator's side, furnished with a full bottom stainless steel shelf
- SE-HC and SES-HC models are standard with Delfield's exclusive Delrite™ ABS or laminated
- modesty panels in front and ends of unit
- Black laminate backs each modesty panel.
- Electrical accessories may change listed amperage and plug
- SES-H models are 30" high overall
- SE-H models are 36" high overall
- One year parts and 90 day labor standard warranty. Additional warranties available, see below
- Adapter bars are provided as standard

### Specifications and Prices

MODEL NUMBER	12 X 20 PANS HELD	OVERALL L	D	H	H.P.	AMP	VOLTS	NEMA PLUG	SHIP WEIGHT	FREIGHT CLASS	LIST PRICE
<b>SHELLEYBASIC HOT/COLD SELF-CONTAINED COMBINATION COUNTERS</b>											
SE-HC2	2	39"	29"	36"	1/4	24.0	120	5-30P	350	100	<b>\$9,443</b>
SE-HC3	3	50"	29"	36"	1/4	21.0	120/208-230	14-30P	425	100	<b>\$10,242</b>
SE-HC4	4	64"	29"	36"	1/4	21.0	120/208-230	14-30P	500	100	<b>\$11,054</b>
SE-HC5	5	78"	29"	36"	1/4	42.0	120/208-230	14-60P	575	100	<b>\$12,100</b>
SE-HC6	6	92"	29"	36"	1/3	42.0	120/208-230	14-60P	650	100	<b>\$13,714</b>

Add S for 30" high models. (Example SES-HC)

Choose from Laminate or Delfield's exclusive Delrite™ ABS panels. ABS panels are available in black & light blue. Contact Delfield for a color chart or visit [www.delfield.com](http://www.delfield.com).

### Product Information

- SE-I and SES-I Series counters are standard with stainless steel ice pan, perforated false bottom, drain with valve and 5" swivel, locking casters
- 16 gauge stainless steel tops.
- SE-I and SES-I are open on the operator's side, furnished with a full bottom stainless steel shelf
- SE-I and SES-I models are standard with Delfield's exclusive Delrite™ ABS or laminated melamine panels in front and ends of unit
- Black laminate backs each modesty panel.
- SES-I models are 30" high overall
- SE-I models are 36" high overall
- One year parts and 90 day labor standard warranty. Additional warranties available, see below

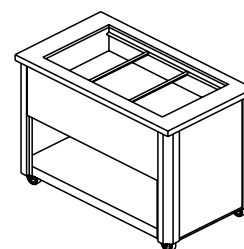

**SE-I3**

### Specifications and Prices

MODEL NUMBER	12 X 20 PANS HELD	OVERALL L	D	H	SHIP WEIGHT	FREIGHT CLASS	LIST PRICE
<b>SHELLEYBASIC ICE COOLED SERVING COUNTERS</b>							
SE-I2	2	39"	29"	36"	200	100	<b>\$4,067</b>
SE-I3	3	50"	29"	36"	245	100	<b>\$4,491</b>
SE-I4	4	64"	29"	36"	280	100	<b>\$5,217</b>
SE-I5	5	78"	29"	36"	330	100	<b>\$5,937</b>
SE-I6	6	92"	29"	36"	380	100	<b>\$6,963</b>

Add S for 30" high models. (Example SES-I)

Shelleybasic accessories and modifications can be found on pages 83-86.

#### Additional Warranties

Net Pricing

One year parts and labor contract --- \$279

Two year parts and labor contract -- \$523

Five year compressor warranty

1/4 H.P. ----- \$108

1/3 H.P. ----- \$128

# SE-F/SES-F SERIES - FROST TOP SERVING COUNTERS

## SE-U/SES-U SERIES - UTILITY COUNTERS



**SE-F2**

Shown with optional fold-down tray slide (SE-A)

### Product Information

- SE-F and SES-F Series counters are standard with stainless steel frost top, condensing units, cord and plug and 5" diameter swivel, locking casters
- 16 gauge stainless steel tops.
- All electrical connections are 60 hertz, single phase
- SE-F and SES-F units open on the operator's side, furnished with a full bottom stainless steel shelf
- SE-F and SES-F models are standard with Delfield's exclusive Delrite™ ABS or laminated modesty panels in front and ends of unit
- Black laminate backs each modesty panel.
- SES-F models are 30" high overall
- SE-F models are 36" high overall
- One year parts and 90 day labor standard warranty. Additional warranties available, see below.

### Specifications and Prices

MODEL NUMBER	Description	OVERALL			AMP	H.P.	VOLTS	NEMA PLUG	SHIP WEIGHT	FREIGHT CLASS	LIST PRICE
		L	D	H							
<b>SHELLEYBASIC FROST TOP SERVING COUNTERS</b>											
SE-F2	frost top	39"	29"	36"	7.5	1/4	115	5-15P	370	100	\$7,357
SE-F3	frost top	50"	29"	36"	7.5	1/4	115	5-15P	445	100	\$8,246
SE-F4	frost top	64"	29"	36"	7.5	1/4	115	5-15P	530	100	\$9,202
SE-F5	frost top	78"	29"	36"	8	1/4	115	5-15P	600	100	\$9,854
SE-F6	frost top	92"	29"	36"	8	1/3	115	5-15P	670	100	\$11,265

Add S for 30" high models. (Example SES-F)

Choose from Laminate or Delfield's exclusive Delrite™ ABS panels. ABS panels are available in black & light blue. Contact Delfield for a color chart or visit [www.delfield.com](http://www.delfield.com).



**SE-U3**

### Product Information

- SE-U and SES-U Series counters are standard with stainless steel flat top and 5" swivel, locking casters
- 16 gauge stainless steel tops.
- SE-U and SES-U are open on the operator's side, furnished with a full bottom stainless steel shelf
- SE-U and SES-U models are standard with Delfield's exclusive Delrite™ ABS or laminated modesty panels in front and ends of unit
- Black laminate backs each modesty panel.
- SES-U models are 30" high overall
- SE-U models are 36" high overall
- Optional urn troughs may be added to unit to provide a beverage counter
- One year parts and 90 day labor standard warranty. Additional warranties available, see below.

### Specifications and Prices

MODEL NUMBER	DESCRIPTION	OVERALL			SHIP WEIGHT	FREIGHT CLASS	LIST PRICE
		L	D	H			
<b>SHELLEYBASIC UTILITY COUNTERS</b>							
SE-U2	utility, flat counter	39"	29"	36"	150	100	\$2,653
SE-U3	utility, flat counter	50"	29"	36"	170	100	\$3,203
SE-U4	utility, flat counter	64"	29"	36"	200	100	\$3,626
SE-U5	utility, flat counter	78"	29"	36"	230	100	\$4,141
SE-U6	utility, flat counter	92"	29"	36"	280	100	\$5,020

Add S for 30" high models. (Example SES-U)

Shelleybasic accessories and modifications can be found on pages 83-86.

#### Additional Warranties

Net Pricing  
 One year parts and labor contract --- \$279  
 Two year parts and labor contract -- \$523  
 Five year compressor warranty  
 1/4 H.P. ----- \$108  
 1/3 H.P. ----- \$128



# SE-CS SERIES - CASHIER STANDS

## SE-TS SERIES - TRAY STANDS



### Product Information

#### SE-CS Series

- Locking stainless steel cash drawer, stainless steel shelf and 5" diameter swivel, locking casters
- 3" grommet hole supplied in top rear for electrical cords
- 16 gauge stainless steel top, welded, ground and polished into one integral unit
- SE-CS models are standard with Delfield's exclusive Delrite™ ABS or laminated modesty panels in front and ends of unit
- Black laminate backs each modesty panel.
- SES-CS models are 30" high overall
- SE-CS models are 36" high overall

#### SE-TS Series

- Locking casters, stainless steel top and tray platform. Silverware cutouts and cylinders are optional
- 16 gauge stainless steel top, welded, ground and polished into one integral unit
- SES-TS models are 30" high overall
- SE-TS models are 36" high overall
- One year parts and 90 day labor standard warranty. Additional warranties available, see below



**SE-CS**

### Specifications and Prices

MODEL NUMBER	DESCRIPTION	OVERALL			SHIP WEIGHT	FREIGHT CLASS	LIST PRICE
		L	D	H			
<b>SHELLEYBASIC CASHIER STAND</b>							
SE-CS	cashier stand	29"	29"	36"	170	100	<b>\$3,107</b>

#### SHELLEYBASIC TRAY STAND

SE-TS	tray stand	29"	29"	36"	140	100	<b>\$2,353</b>
-------	------------	-----	-----	-----	-----	-----	----------------

Add S for 30" high models. (Example SES-CS)

Shelleybasic accessories and modifications can be found on pages 83-86.

Choose from laminate or Delfield's exclusive Delrite™ ABS panels. ABS panels are available in black & light blue. Contact Delfield for a color chart or visit [www.delfield.com](http://www.delfield.com).



**SE-TS**

**Additional Warranties**  
 Net Pricing  
 One year parts and labor contract --- \$279  
 Two year parts and labor contract -- \$523

**SHELLEYBASIC® SERVING LINES**



# SE-ICE SERIES - ICE CREAM COUNTERS

## SE SERIES - CORNER UNITS

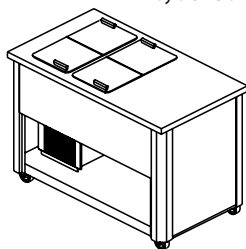

**SE-ICE**

### Product Information

- SE-ICE Series counters are standard with condensing unit, cord and plug, 5" diameter swivel, locking casters and drain
- 16 gauge stainless steel top, welded, ground and polished into one integral unit
- Electrical connections are 60 hertz, single phase.
- SES-ICE models are 30" high overall
- SE-ICE models are 36" high overall
- SE-ICE models are standard with Delfield exclusive Delrite™ ABS or laminated modesty panels in front and ends of unit
- Black laminate backs each modesty panel.
- One year parts and 90 day labor standard warranty. Additional warranties available, see below

### Specifications and Prices

MODEL NUMBER	DESCRIPTION	OVERALL			AMPS	HP	VOLTS	NEMA PLUG	SHIP WEIGHT	FREIGHT CLASS	LIST PRICE
		L	D	H							
<b>SHELLEYBASIC ICE CREAM COUNTERS - 0°F STORAGE ONLY</b>											
SE-ICE1	84 CUPS	39"	29"	36"	5.3	1/4	115	5-15P	460	100	<b>\$8,138</b>
SE-ICE2	224 CUPS	50"	29"	36"	5.3	1/4	115	5-15P	505	100	<b>\$10,172</b>

Add S for 30" high models. (Example SES-ICE1)  
Capacity on 30" high models: SES-ICE1 = 84 and SES-ICE2 = 224

Shelleybasic accessories and modifications can be found on pages 83-86.

Choose from Laminate or Delfield's exclusive Delrite™ ABS panels. ABS panels are available in black & light blue. Contact Delfield for a color chart or visit [www.delfield.com](http://www.delfield.com).



**SE-39**

### Product Information

- SE Series corner units are standard with stainless steel flat top and 5" diameter swivel, locking casters
- 16 gauge stainless steel top
- SE-S models are standard with Delfield exclusive Delrite™ ABS or laminated modesty panels in front and ends of unit
- Black laminate backs each modesty panel.
- SE-S models are 30" high overall
- SE models are 36" overall
- One year parts and 90 day labor standard warranty. Additional warranties available, see below

### Specifications and Prices

MODEL NUMBER	DESCRIPTION	OVERALL			SHIP WEIGHT	FREIGHT CLASS	LIST PRICE
		L	D	H			
<b>CORNER UNITS</b>							
SE-29	corner units	29"	29"	36"	110	100	<b>\$2,569</b>
SE-39	corner units	39"	29"	36"	160	100	<b>\$2,653</b>

Add S for 30" models. (Example SES-29)

Shelleybasic accessories and modifications can be found on pages 83-86.

**Additional Warranties**  
Net Pricing  
One year parts and labor contract --- \$279  
  
Two year parts and labor contract -- \$523  
  
Five year compressor warranty  
1/4 H.P. ----- \$108



# SHELLEYBASIC EQUIPMENT ACCESSORIES

SEE PAGES 83-86 FOR ACCESSORIES AND MODIFICATIONS PRICING.



SE-A. 10" stainless steel fold-down tray slide



SE-D. 8" polyethylene fold-down cutting board



SE-E. 8" stainless steel fold-down work shelf



SE-U. 14" x 29" stainless steel end drop shelf



Lidlock



SE-SL. Sliding doors.

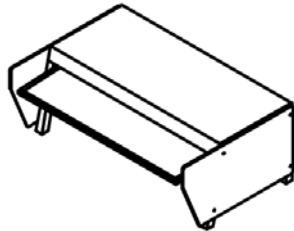

G. Glass front counter protector

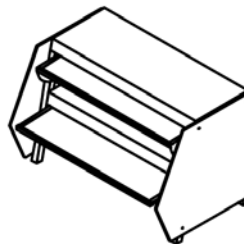

H. Two-tier display w/glass shelves and sneeze guards

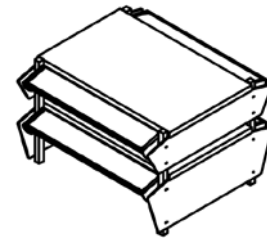

HD. Double service two-tier display with glass shelves and sneeze guards

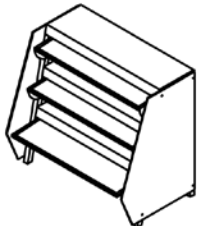

I. Three-tier display w/glass shelves and sneeze guards

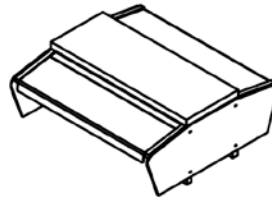

KD. Double service flip-up sneeze guard shown with optional powder coating

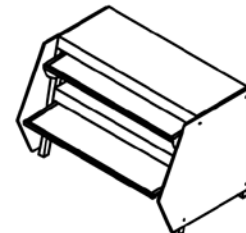

KS. Single service flip-up sneeze guard shown with optional powder coating

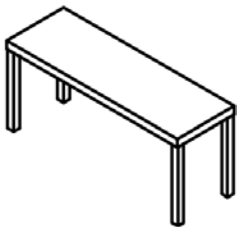

J. 12" stainless steel overshelf, 18-gauge

SHELLEYBASIC® SERVING LINES

# SHELLEYBASIC ACCESSORIES AND MODIFICATIONS

SE-H/SES-H Accessories		-2	-3	-4	-5	-6
SE-A	10" Stainless steel fold-down tray slide	\$677	\$851	\$1,021	\$1,263	\$1,263
SE-D	8" Polyethylene fold-down cutting board	\$683	\$759	\$943	\$1,109	\$1,491
SE-E	8" Stainless steel fold-down work shelf	\$571	\$801	\$962	\$1,193	\$1,523
SE-F	Alignment pin (2 per unit)	\$253	\$253	\$253	\$253	\$253
SE-J	12" Stainless steel overshelf	\$423	\$612	\$664	\$923	\$1,164
SE-J2	Two tier 12" stainless steel overshelf	\$839	\$1,220	\$1,326	\$1,853	\$2,326
SE-LI	Light fixture (per tier)	\$466	\$531	\$666	\$797	\$927
SE-M	Radiant heat lamp with on/off switch	\$943	\$999	\$1,147	\$1,332	\$1,802
SE-Q	115/115A outlet	\$566	\$566	\$566	\$566	\$566
SE-U	14" x 29" Stainless steel end drop shelf	\$2,653	\$3,203	\$3,626	\$4,141	\$5,020
SE-V	Adjustable stainless steel leg	\$264	\$264	\$264	\$264	\$264
SE-SL	Sliding doors	\$733	\$964	\$1,232	\$1,502	\$1,773

SE-C/SES-C Accessories		-2	-3	-4	-5	-6
SE-A	10" Stainless steel fold-down tray slide	\$677	\$851	\$1,021	\$1,263	\$1,263
SE-D	8" Polyethylene fold-down cutting board	\$683	\$759	\$943	\$1,109	\$1,491
SE-E	8" Stainless steel fold-down work shelf	\$571	\$801	\$962	\$1,193	\$1,523
SE-F	Alignment pin (2 per unit)	\$253	\$253	\$253	\$253	\$253
SE-J	12" Stainless steel overshelf	\$423	\$612	\$664	\$923	\$1,164
SE-J2	Two tier 12" stainless steel overshelf	\$839	\$1,220	\$1,326	\$1,853	\$2,326
SE-LI	Light fixture (per tier)	\$466	\$531	\$666	\$797	\$927
SE-M	Radiant heat lamp with on/off switch	\$943	\$999	\$1,147	\$1,332	\$1,802
SE-Q	115/115A outlet	\$566	\$566	\$566	\$566	\$566
SE-U	14" x 29" Stainless steel end drop shelf	\$2,653	\$3,203	\$3,626	\$4,141	\$5,020
SE-V	Adjustable stainless steel leg	\$264	\$264	\$264	\$264	\$264

SE-HC/SES-HC Accessories		-2	-3	-4	-5	-6
SE-A	10" Stainless steel fold-down tray slide	\$677	\$851	\$1,021	\$1,263	\$1,263
SE-D	8" Polyethylene fold-down cutting board	\$683	\$759	\$943	\$1,109	\$1,491
SE-E	8" Stainless steel fold-down work shelf	\$571	\$801	\$962	\$1,193	\$1,523
SE-F	Alignment pin (2 per unit)	\$253	\$253	\$253	\$253	\$253
SE-J	12" Stainless steel overshelf	\$423	\$612	\$664	\$923	\$1,164
SE-J2	Two tier 12" stainless steel overshelf	\$839	\$1,220	\$1,326	\$1,853	\$2,326
SE-LI	Light fixture (per tier)	\$466	\$531	\$666	\$797	\$927
SE-M	Radiant heat lamp with on/off switch	\$943	\$999	\$1,147	\$1,332	\$1,802
SE-Q	115/115A outlet	\$566	\$566	\$566	\$566	\$566
SE-U	14" x 29" Stainless steel end drop shelf	\$2,653	\$3,203	\$3,626	\$4,141	\$5,020
SE-V	Adjustable stainless steel leg	\$264	\$264	\$264	\$264	\$264



# SHELLEYBASIC ACCESSORIES AND MODIFICATIONS

SE-I/SES-I Accessories		-2	-3	-4	-5	-6
SE-A	10" Stainless steel fold-down tray slide	\$677	\$851	\$1,021	\$1,263	\$1,263
SE-D	8" Polyethylene fold-down cutting board	\$683	\$759	\$943	\$1,109	\$1,491
SE-E	8" Stainless steel fold-down work shelf	\$571	\$801	\$962	\$1,193	\$1,523
SE-F	Alignment pin (2 per unit)	\$253	\$253	\$253	\$253	\$253
SE-J	12" Stainless steel overshelf	\$423	\$612	\$664	\$923	\$1,164
SE-J2	Two tier 12" stainless steel overshelf	\$839	\$1,220	\$1,326	\$1,853	\$2,326
SE-LI	Light fixture (per tier)	\$466	\$531	\$666	\$797	\$927
SE-M	Radiant heat lamp with on/off switch	\$943	\$999	\$1,147	\$1,332	\$1,802
SE-Q	115/115A outlet	\$566	\$566	\$566	\$566	\$566
SE-U	14" x 29" Stainless steel end drop shelf	\$2,653	\$3,203	\$3,626	\$4,141	\$5,020
SE-V	Adjustable stainless steel leg	\$264	\$264	\$264	\$264	\$264
SE-SL	Sliding doors	\$733	\$964	\$1,232	\$1,502	\$1,773

SE-F/SES-F Accessories		-2	-3	-4	-5	-6
SE-A	10" Stainless steel fold-down tray slide	\$677	\$851	\$1,021	\$1,263	\$1,263
SE-D	8" Polyethylene fold-down cutting board	\$683	\$759	\$943	\$1,109	\$1,491
SE-E	8" Stainless steel fold-down work shelf	\$571	\$801	\$962	\$1,193	\$1,523
SE-F	Alignment pin (2 per unit)	\$253	\$253	\$253	\$253	\$253
SE-J	12" Stainless steel overshelf	\$423	\$612	\$664	\$923	\$1,164
SE-J2	Two tier 12" stainless steel overshelf	\$839	\$1,220	\$1,326	\$1,853	\$2,326
SE-LI	Light fixture (per tier)	\$466	\$531	\$666	\$797	\$927
SE-M	Radiant heat lamp with on/off switch	\$943	\$999	\$1,147	\$1,332	\$1,802
SE-Q	115/115A outlet	\$566	\$566	\$566	\$566	\$566
SE-U	14" x 29" Stainless steel end drop shelf	\$2,653	\$3,203	\$3,626	\$4,141	\$5,020
SE-V	Adjustable stainless steel leg	\$264	\$264	\$264	\$264	\$264

SE-U/SES-U Accessories		-2	-3	-4	-5	-6
SE-A	10" Stainless steel fold-down tray slide	\$677	\$851	\$1,021	\$1,263	\$1,263
SE-D	8" Polyethylene fold-down cutting board	\$683	\$759	\$943	\$1,109	\$1,491
SE-E	8" Stainless steel fold-down work shelf	\$571	\$801	\$962	\$1,193	\$1,523
SE-F	Alignment pin (2 per unit)	\$253	\$253	\$253	\$253	\$253
SE-FE	Ferruled hole – 1" diameter	\$84	\$84	\$84	\$84	\$84
SE-J	12" Stainless steel overshelf	\$423	\$612	\$664	\$923	\$1,164
SE-J2	Two tier 12" stainless steel overshelf	\$839	\$1,220	\$1,326	\$1,853	\$2,326
SE-LI	Light fixture (per tier)	\$466	\$531	\$666	\$797	\$927
SE-M	Radiant heat lamp with on/off switch	\$943	\$999	\$1,147	\$1,332	\$1,802
SE-Q	115/115A outlet	\$566	\$566	\$566	\$566	\$566
SE-U	14" x 29" Stainless steel end drop shelf	\$2,653	\$3,203	\$3,626	\$4,141	\$5,020
SE-URN	Urn Trough	\$467	\$822	\$827	\$847	\$860
SE-V	Adjustable stainless steel leg	\$264	\$264	\$264	\$264	\$264
SE-SL	Sliding doors	\$733	\$964	\$1,232	\$1,502	\$1,773

# SHELLEYBASIC ACCESSORIES AND MODIFICATIONS

SE-CS/SE-TS ACCESSORIES		-2	-3	-4	-5	-6
SE-A	10" Stainless steel fold-down tray slide	\$677	\$851	\$1,021	\$1,263	\$1,263
SE-D	8" Polyethylene fold-down cutting board	\$683	\$759	\$943	\$1,109	\$1,491
SE-E	8" Stainless steel fold-down work shelf	\$571	\$801	\$962	\$1,193	\$1,523
SE-F	Alignment pin (2 per unit)	\$253	\$253	\$253	\$253	\$253
SE-Q	115/115A outlet	\$566	\$566	\$566	\$566	\$566
SE-U	14" x 29" Stainless steel end drop shelf	\$410	\$410	\$410	\$410	\$410
SE-V	Adjustable stainless steel leg	\$264	\$264	\$264	\$264	\$264
SE-SL	Sliding doors	\$733	\$964	\$1,232	\$1,502	\$1,773
SE-FE	Ferruled hole – 1" diameter	\$84	\$84	\$84	\$84	\$84
SE-SW8	8 Silverware holders	\$827	\$827	\$827	\$827	\$827
SE-ICE Accessories		-2	-3	-4	-5	-6
SE-A	10" Stainless steel fold-down tray slide	\$677	\$851	\$1,021	\$1,263	\$1,263
SE-D	8" Polyethylene fold-down cutting board	\$683	\$759	\$943	\$1,109	\$1,491
SE-E	8" Stainless steel fold-down work shelf	\$571	\$801	\$962	\$1,193	\$1,523
SE-F	Alignment pin (2 per unit)	\$253	\$253	\$253	\$253	\$253
SE-Q	115/115A outlet	\$566	\$566	\$566	\$566	\$566
SE-U	14" x 29" Stainless steel end drop shelf	\$410	\$410	\$410	\$410	\$410
SE-V	Adjustable stainless steel leg	\$264	\$264	\$264	\$264	\$264
SE Accessories		-2	-3	-4	-5	-6
SE-A	10" Stainless steel fold-down tray slide	\$677	\$851	\$1,021	\$1,263	\$1,263
SE-D	8" Polyethylene fold-down cutting board	\$683	\$759	\$943	\$1,109	\$1,491
SE-E	8" Stainless steel fold-down work shelf	\$571	\$801	\$962	\$1,193	\$1,523
SE-F	Alignment pin (2 per unit)	\$253	\$253	\$253	\$253	\$253
SE-FE	Ferruled hole – 1" diameter	\$84	\$84	\$84	\$84	\$84
SE-Q	115/115A outlet	\$566	\$566	\$566	\$566	\$566
SE-U	14" x 29" Stainless steel end drop shelf	\$410	\$410	\$410	\$410	\$410
SE-V	Adjustable stainless steel leg	\$264	\$264	\$264	\$264	\$264
SE-SL	Sliding doors	\$733	\$964	\$1,232	\$1,502	\$1,773
SE-PSS20	20-gauge stainless steel panels	\$593	\$739	\$907	\$1,145	\$1,264
Shelleybasic Counter Protectors		-39	-50	-64	-78	-92
G	Glass front counter protector	\$1,717	\$1,823	\$2,322	\$2,764	\$2,878
H	Two-tier display w/glass shelves & sneeze guard	\$2,629	\$3,262	\$4,142	\$5,150	\$5,080
HD	Double service two-tier display with sneeze guard	\$3,406	\$3,950	\$5,093	\$6,179	\$6,552
I	Three-tier display w/glass shelves & sneeze guard	\$5,019	\$5,593	\$6,343	\$7,434	\$8,379
J	12" stainless steel overshef, 18-gauge	\$686	\$916	\$1,070	\$1,463	\$1,672
KD	Double service flip-up sneeze guard	\$1,878	\$1,980	\$2,540	\$3,106	\$3,158
KS	Single service flip-up sneeze guard	\$1,314	\$1,479	\$1,848	\$2,268	\$2,193

# SH SERIES - MOBILE HEATED SERVING COUNTERS



## Product Information

- 14-gauge stainless steel top
- 18-gauge stainless steel exterior body
- 14-gauge galvanized bottom
- SH units have heated under storage compartment, provided with removable pan slides. SH-NU units have enclosed bases with no under storage
- A maximum 10' long cord and plug are supplied standard
- Electrical connections are 60 hertz, single phase. Three-phase design is available for an additional charge. Electrical accessories may change listed amperage and plug
- Top has two to six electrically heated, recessed die stamped stainless steel hot food warmers. Each warmer accommodates one 12" x 20" x 6" pan
- All exterior panels reinforced with overlapping corners, welded in place
- All body cutouts reinforced with 14-gauge channel supports
- Choose from an almost unlimited selection of laminate colors and textures to add color to any room
- All units are standard on 5" diameter polyurethane swivel casters for easy cleaning
- Easy to use stainless steel interlock system is standard on base and tray slides
- Easily modified with a complete array of standard accessories
- Counter heights available from 28" to 36" in 2" increments
- Add eye catching decal packages or bright canopies to create a distinctive look!
- Features new easy access panel for quick replacement of heating element.
- One year parts and 90 day labor standard warranty. Additional warranties available, see below



### SH-3-NU

Shown with the following options:  
 G—glass front counter protector  
 A—12" stainless steel V fold-down tray slide



### SH-4-NU

Shown with the following options:  
 KS—glass front counter protector  
 A—12" stainless steel V fold-down tray slide

## Specifications and Prices

MODEL NUMBER	DESCRIPTION	OVERALL			AMP	VOLTS	WATTS	NEMA PLUG	SHIP WEIGHT	FREIGHT CLASS	LIST PRICE
		L	D	H							
<b>SHELLEYSTEEL HEATED SERVING COUNTERS</b>											
<b>With heated understorage</b>											
SH-2	2 food wells	36"	30"	36"	15.0	120/208-230	2900/3300	14-20P	380	100	<b>\$9,842</b>
SH-3	3 food wells	50"	30"	36"	20.0	120/208-230	3900/4500	14-30P	460	100	<b>\$11,254</b>
SH-4	4 food wells	60"	30"	36"	26.0	120/208-230	4900/5700	14-50P	550	100	<b>\$12,180</b>
SH-5	5 food wells	74"	30"	36"	31.0	120/208-230	5900/6900	14-50P	660	100	<b>\$13,415</b>
SH-6	6 food wells	96"	30"	36"	37.0	120/208-230	6900/7900	14-50P	720	100	<b>\$14,799</b>
<b>Without understorage</b>											
SH-2-NU	2 food wells	36"	30"	36"	11.0	120/208-230	2000/2400	14-20P	225	100	<b>\$6,378</b>
SH-3-NU	3 food wells	50"	30"	36"	16.0	120/208-230	3000/3600	14-20P	275	100	<b>\$7,341</b>
SH-4-NU	4 food wells	60"	30"	36"	22.0	120/208-230	4000/4800	14-30P	330	100	<b>\$8,234</b>
SH-5-NU	5 food wells	74"	30"	36"	28.0	120/208-230	5000/6000	14-50P	420	100	<b>\$9,445</b>
SH-6-NU	6 food wells	96"	30"	36"	33.0	120/208-230	6000/7000	14-50P	510	100	<b>\$10,795</b>

Shelleysteel accessories and modifications can be found on pages 105-114.

**Additional Warranties**  
 Net Pricing  
 One year parts and labor contract --- \$279  
 Two year parts and labor contract --- \$523

# SCSC-B SERIES - MOBILE REFRIGERATED COLD PAN SERVING COUNTERS

## SCSC-EF SERIES - LIQUITEC REFRIGERATED COLD PAN



**SCSC-74-B**  
pans by others



**SCSC-60-EF**

Shown with optional laminate, canopy, custom counter protector and extended base



Patented LiquiTec® Technology brings food and pans completely flush!

### Product Information

- 14-gauge stainless steel top
- 18-gauge stainless steel exterior body
- 14-gauge galvanized bottom
- On/off switch mounted to exterior of unit
- A maximum 10' long cord and plug are supplied standard
- All exterior panels reinforced with overlapping corners, welded in place
- All body cutouts reinforced with 14-gauge channel supports
- Choose from an almost unlimited selection of laminate colors and textures to add color to any room
- Electrical connections are 60 hertz, single phase. Electrical accessories may change listed amperage and plug
- All units are standard on 5" polyurethane swivel casters for easy cleaning
- Easy to use stainless steel interlock system is standard on base and tray slides
- Easily modified with a complete array of standard accessories
- Add eye catching decal packages or bright canopies to create a distinctive look!
- Counter heights available from 28" to 36" in 2" increments
- Environmentally friendly HFC-404A refrigerant
- One year parts and 90 day labor standard warranty. Additional warranties available, see below

### SCSC-B

- SCSC-B Series counters are standard with 7" deep refrigerated cold pan. Cold pans are fully insulated with foamed in place polyurethane insulation
- Pans recessed 2" from top edge of counter
- SCSC-B models are standard with enclosed base
- Cold pans are standard with drain with valve
- Adapter bars will be furnished at no additional charge if requested on original order only. Pans are supplied by others
- Optional open shelf and dry door inserts can be added to all models and lengths. Refrigerated insert can be added to 60", 74", or 96" long units

### SCSC-EF

- The LiquiTec cold pan has two – six die stamped openings with depressed edges, each well, holding one 12" x 20" pan (pans supplied by others)
- Eutectic fluid completely surrounds each cold pan providing the maximum-- five sided cooling
- All SCSC-EF models meet NSF 7 with pans completely flush with counter
- Cold pan is fully insulated with foamed in place polyurethane insulation

### Specifications and Prices

MODEL NUMBER	COLD PAN SIZE	DIMENSIONS			AMP	H.P.	VOLTS	NEMA PLUG	SHIP WEIGHT	FREIGHT CLASS	LIST PRICE
		L	D	H							
<b>SHELLEYSSTEEL REFRIGERATED COLD PAN SERVING COUNTERS</b>											
<b>SCSC-36-B</b>	26" X 21.62"	36"	30"	36"	7.0	1/4	115	5-15P	350	100	<b>\$10,778</b>
<b>SCSC-50-B</b>	39" X 21.62"	50"	30"	36"	7.0	1/4	115	5-15P	425	100	<b>\$11,238</b>
<b>SCSC-60-B</b>	52" X 21.62"	60"	30"	36"	7.0	1/4	115	5-15P	500	100	<b>\$11,616</b>
<b>SCSC-74-B</b>	65" X 21.62"	74"	30"	36"	7.0	1/4	115	5-15P	575	110	<b>\$13,774</b>
<b>SCSC-96-B</b>	78" X 21.62"	96"	30"	36"	7.0	1/4	115	5-15P	650	110	<b>\$14,654</b>

### SHELLEYSSTEEL LIQUITEC COLD PAN SERVING COUNTER WITH PATENTED LiquiTec® TECHNOLOGY

<b>SCSC-36-EF</b>	2 pan cap	36"	30"	36"	7.0	1/4	115	5-15P	380	100	<b>\$12,321</b>
<b>SCSC-50-EF</b>	3 pan cap	50"	30"	36"	7.0	1/4	115	5-15P	455	100	<b>\$12,844</b>
<b>SCSC-60-EF</b>	4 pan cap	60"	30"	36"	7.0	1/4	115	5-15P	530	100	<b>\$13,275</b>
<b>SCSC-74-EF</b>	5 pan cap	74"	30"	36"	7.0	1/4	115	5-15P	615	100	<b>\$14,561</b>
<b>SCSC-96-EF</b>	6 pan cap	96"	30"	36"	7.0	1/4	115	5-15P	680	100	<b>\$16,748</b>

Shelleysteel accessories and modifications can be found on pages 105-114.

#### Additional Warranties Net Pricing

One year parts and labor contract --- \$279

Two year parts and labor contract -- \$523

Five year compressor warranty  
1/4 H.P. ----- \$108



# SHCR-B SERIES - HOT/COLD COMBINATION COUNTERS

## SHC SERIES- ICE COOLED HOT/COLD COMBINATION COUNTERS



### Product Information

- Save space by having both hot and cold in one convenient location
- 14-gauge stainless steel top
- 18-gauge stainless steel exterior body
- 14-gauge galvanized bottom
- All SHCR-B models are standard with enclosed bases
- Top has one to four electrically heated, recessed die-stamped stainless steel hot food warmers. Each warmer accommodates a 12" x 20" x 6" pan (pans supplied by others)
- Note: When lights with heat lamps are used over hot wells, incandescent light fixtures will be used due to heat.
- A maximum 10' long cord and plug are supplied standard
- Electrical connections are 60 hertz, single phase. Three-phase design is available for an additional charge. Electrical accessories may change listed amperage and plug
- All exterior panels reinforced with overlapping corners, welded in place
- All body cutouts reinforced with 14-gauge channel supports
- Choose from an almost unlimited selection of laminate colors and textures to add color to any room
- All units are standard on 5" diameter polyurethane swivel casters for easy cleaning
- Easy to use stainless steel interlock system is standard on base and tray slides
- Easily modified with a complete array of standard accessories
- Counter heights available from 28" to 36" in 2" increments
- Add eye catching decal packages or bright canopies to create a distinctive look!
- One year parts and 90 day labor standard warranty. Additional warranties available, see below



### SH2CR-60-B

- Shown with the following options:
- A. 12" stainless steel V fold down
  - E. 10" wide stainless steel folddown work shelf
  - KS. single service flip up sneeze guard
  - U. End shelf

### SHCR-B ONLY

- The refrigerated cold pan is 7" deep constructed of stainless steel. Cold pan is equipped with a 1" drain with valve
- Meets NSF requirements with 3" recessed pans
- Environmentally friendly HFC-404A refrigerant

### SHC ONLY

- Insulated ice pan is 7" deep and constructed of 22-gauge stainless steel. Perforated false bottom, and drain with valve is standard

### Specifications and Prices

MODEL NUMBER	HOT WELLS	COLD PAN SIZE	DIMENSIONS			AMP	H.P.	VOLTS	WATTS	NEMA PLUG	SHIP WEIGHT	FREIGHT CLASS	LIST PRICE
<b>SHELLEYSTEEL SELF-CONTAINED HOT AND COLD COMBINATION COUNTERS</b>													
SHCR-50-B	1	26" X 21.62"	50"	30"	36"	16.0	1/4	120	1000	5-20P	475	100	\$11,973
SHCR-60-B	1	39" X 21.62"	60"	30"	36"	16.0	1/4	120	1000	5-20P	575	100	\$12,661
SH2CR-62-B	2	26" X 21.62"	62"	30"	36"	18.0	1/4	120/208-230	2000/2400	14-30P	575	100	\$13,505
SHCR-74-B	1	52" X 21.62"	74"	30"	36"	16.0	1/4	120	1000	5-20P	688	100	\$14,339
SH2CR-74-B	2	39" X 21.62"	74"	30"	36"	18.0	1/4	120/208-230	2000/2400	14-30P	690	100	\$15,206
SHCR-96-B	1	65" X 21.62"	96"	30"	36"	16.0	1/4	120	1000	5-20P	730	100	\$17,284
SH2CR-96-B	2	52" X 21.62"	96"	30"	36"	18.0	1/4	120/208-230	2000/2400	14-30P	740	100	\$18,357
SH3CR-96-B	3	39" X 21.62"	96"	30"	36"	23.0	1/4	120/208-230	3000/3600	14-30P	750	100	\$19,257
SH4CR-96-B	4	26" X 21.62"	96"	30"	36"	29.0	1/4	120/208-230	4000/4800	14-50P	760	100	\$20,521

Shelleysteel accessories and modifications can be found on pages 105-114.  
For LiquiTec® option, see accessory pages.

### Specifications and Prices

MODEL NUMBER	HOT WELLS	COLD PAN SIZE	OVERALL			AMP	H.P.	VOLTS	MAX WATTS	NEMA PLUG	SHIP WEIGHT	FREIGHT CLASS	LIST PRICE
<b>SHELLEYSTEEL ICE-COOLED HOT AND COLD COMBINATION COUNTERS</b>													
SHC-50-NU	1	26" X 21.62"	50"	30"	36"	9.0	—	120	1000	5-15P	300	100	\$8,611
SHC-60-NU	1	26" X 21.62"	60"	30"	36"	9.0	—	120	1000	5-15P	350	100	\$9,474
SH2C-62-NU	2	26" X 21.62"	62"	30"	36"	11.0	—	120/208-230	2000/2400	14-20P	350	100	\$9,206
SHC-74-NU	1	52" X 21.62"	74"	30"	36"	9.0	—	120	1000	5-15P	400	100	\$11,047
SH2C-74-NU	2	26" X 21.62"	74"	30"	36"	11.0	—	120/208-230	2000/2400	14-20P	410	100	\$12,102
SH3C-74-NU	3	26" X 21.62"	74"	30"	36"	16.0	—	120/208-230	3000/3600	14-20P	420	100	\$13,422
SHC-96-NU	1	65" X 21.62"	96"	30"	36"	9.0	—	120	1000	5-15P	425	100	\$14,063
SH2C-96-NU	2	52" X 21.62"	96"	30"	36"	11.0	—	120/208-230	2000/2400	14-20P	430	100	\$15,163
SH3C-96-NU	3	39" X 21.62"	96"	30"	36"	16.0	—	120/208-230	3000/3600	14-20P	450	100	\$16,208
SH4C-96-NU	4	26" X 21.62"	96"	30"	36"	22.0	—	120/208-230	4000/4800	14-30P	460	100	\$17,534

Shelleysteel accessories and modifications can be found on pages 105-114.

**Additional Warranties**  
Net Pricing

One year parts and labor contract --- \$279

Two year parts and labor contract -- \$523

Five year compressor warranty  
1/4 H.P. ----- \$108



# SCFT-NU SERIES - FROST TOP SERVING COUNTERS



**SCFT-74-NU**



Add eye catching decal packages or bright canopies to create a distinctive look!

## Product Information

- 14-gauge stainless steel top
- 18-gauge stainless steel exterior body
- 14-gauge galvanized bottom
- Frost top is 18-gauge stainless steel, one piece construction; perimeter drain with valve located at bottom of unit standard
- 18" x 26" sheet pan can rest on frost top
- On/off switch located on exterior of unit
- SCFT units are standard with enclosed base
- Meets NSF requirements
- Environmentally friendly R404A refrigerant
- A maximum 10' long cord and plug are supplied standard
- Electrical connections are 60 hertz, single phase. Electrical accessories may change listed amperage and plug
- All exterior panels reinforced with overlapping corners, welded in place
- All body cutouts reinforced with 14-gauge channel supports
- All units are standard on 5" diameter polyurethane swivel casters for easy cleaning
- Easy to use stainless steel interlock system is standard on base and tray slides
- Easily modified with a complete array of standard accessories
- Counter heights available from 28" to 36" in 2" increments
- Choose from an almost unlimited selection of laminate colors and textures to add color to any room
- Add eye catching decal packages or bright canopies to create a distinctive look!
- Environmentally friendly HFC-404A refrigerant
- One year parts and 90 day labor standard warranty. Additional warranties available, see below

## Specifications and Prices

MODEL NUMBER	DESCRIPTION	OVERALL			AMP	H.P.	VOLTS	NEMA PLUG	SHIP WEIGHT	FREIGHT CLASS	LIST PRICE
		L	D	H							
<b>SHELLEYSSTEEL FROST TOP SERVING COUNTERS</b>											
<b>Without understorage</b>											
<b>SCFT-36-NU</b>	frost top	36"	30"	36"	7.0	1/4	115	5-15P	380	100	<b>\$10,596</b>
<b>SCFT-50-NU</b>	frost top	50"	30"	36"	7.0	1/4	115	5-15P	455	100	<b>\$11,872</b>
<b>SCFT-60-NU</b>	frost top	60"	30"	36"	7.0	1/4	115	5-15P	540	100	<b>\$13,250</b>
<b>SCFT-74-NU</b>	frost top	74"	30"	36"	8.0	1/3	115	5-15P	610	110	<b>\$14,190</b>
<b>SCFT-96-NU</b>	frost top	96"	30"	36"	8.0	1/3	115	5-15P	680	110	<b>\$16,219</b>

Shelleysteel accessories and modifications can be found on pages 105-114.

### Additional Warranties Net Pricing

One year parts and labor contract --- \$279

Two year parts and labor contract -- \$523

Five year compressor warranty  
1/4 H.P. ----- \$108  
1/3 H.P. ----- \$128





# SCI SERIES - ICE PAN SERVING COUNTERS



## Product Information

- 14-gauge stainless steel top
- 18-gauge stainless steel exterior body
- 14-gauge galvanized bottom
- Best for use where electricity is not available
- Insulated ice pan is 7" deep and is standard with the following: perforated false bottom, drain with valve and casters
- SCI units are standard with dry hinged door storage compartment, while SCI-NU units have enclosed bases with no under storage
- Meets NSF requirements
- All exterior panels reinforced with overlapping corners, welded in place
- All body cutouts reinforced with 14-gauge channel supports
- All units are standard on 5" diameter polyurethane swivel casters for easy cleaning
- Easy to use stainless steel interlock system is standard on base and tray slides
- Easily modified with a complete array of standard accessories
- Choose from an almost unlimited selection of laminate colors and textures to add color to any room
- Add eye catching decal packages or bright canopies to create a distinctive look!
- One year parts and 90 day labor standard warranty. Additional warranties available, see below



### SCI-60-NU

Shown with the following options:  
 C. 10" wide three-bar fold down tray slide  
 H. Two tier display with glass shelves and sneeze guards

## Specifications and Prices

MODEL NUMBER	ICE PAN SIZE	L	OVERALL D	H	SHIP WEIGHT	FREIGHT CLASS	LIST PRICE
<b>SHELLEYSSTEEL ICE PAN SERVING COUNTERS</b>							
<b>With dry understorage</b>							
SCI-36	26" x 21.62"	36"	30"	36"	240	110	<b>\$8,521</b>
SCI-50	39" x 21.62"	50"	30"	36"	285	110	<b>\$9,052</b>
SCI-60	52" x 21.62"	60"	30"	36"	320	110	<b>\$10,099</b>
SCI-74	65" x 21.62"	74"	30"	36"	360	110	<b>\$11,131</b>
SCI-96	78" x 21.62"	96"	30"	36"	400	110	<b>\$12,926</b>
<b>Without understorage</b>							
SCI-36-NU	26" x 21.62"	36"	30"	36"	200	110	<b>\$5,854</b>
SCI-50-NU	39" x 21.62"	50"	30"	36"	245	110	<b>\$6,469</b>
SCI-60-NU	52" x 21.62"	60"	30"	36"	280	110	<b>\$7,514</b>
SCI-74-NU	65" x 21.62"	74"	30"	36"	330	110	<b>\$8,549</b>
SCI-96-NU	78" x 21.62"	96"	30"	36"	380	110	<b>\$10,026</b>

Shelleysteel accessories and modifications can be found on pages 105-114.

### Additional Warranties Net Pricing

One year parts and labor contract --- \$279

Two year parts and labor contract --- \$523



# SCU SERIES - BEVERAGE COUNTERS



**SCU-50-NU**  
Shown with optional legs

## Product Information

- 14-gauge stainless steel top
- 18-gauge stainless steel exterior body
- 14-gauge galvanized bottom
- Reinforced top includes a stainless steel drain trough with removable stainless steel anti-splash drip gate. (Trough is standard on customer side, available on operator side if specified.)
- Drain trough has a 1" drain plumbed to a drain valve located at the bottom of the unit
- SCU models are standard with dry hinged door storage compartment
- Meets NSF requirements
- All exterior panels reinforced with overlapping corners, welded in place
- All body cutouts reinforced with 14-gauge channel supports
- All units are standard on 5" diameter polyurethane swivel casters for easy cleaning
- Easy to use stainless steel interlock system is standard on base and tray slides
- Easily modified with a complete array of standard accessories
- Choose from an almost unlimited selection of laminate colors and textures to add color to any room
- Add eye catching decal packages or bright canopies to create a distinctive look!
- One year parts and 90 day labor standard warranty. Additional warranties available, see below

## Specifications and Prices

MODEL NUMBER	DESCRIPTION	L	OVERALL D	H	SHIP WEIGHT	FREIGHT CLASS	LIST PRICE
<b>SHELLEYSSTEEL BEVERAGE COUNTERS</b>							
<b>With dry understorage</b>							
<b>SCU-36</b>	24" urn trough	36"	30"	36"	200	125	<b>\$7,058</b>
<b>SCU-50</b>	36" urn trough	50"	30"	36"	230	125	<b>\$7,807</b>
<b>SCU-60</b>	48" urn trough	60"	30"	36"	270	125	<b>\$9,001</b>
<b>SCU-74</b>	60" urn trough	74"	30"	36"	300	125	<b>\$9,970</b>
<b>SCU-96</b>	82" urn trough	96"	30"	36"	340	125	<b>\$11,671</b>
<b>Without understorage</b>							
<b>SCU-36-NU</b>	24" urn trough	36"	30"	36"	170	125	<b>\$4,842</b>
<b>SCU-50-NU</b>	36" urn trough	50"	30"	36"	190	125	<b>\$5,317</b>
<b>SCU-60-NU</b>	48" urn trough	60"	30"	36"	230	125	<b>\$6,258</b>
<b>SCU-74-NU</b>	60" urn trough	74"	30"	36"	260	125	<b>\$7,193</b>
<b>SCU-96-NU</b>	82" urn trough	96"	30"	36"	300	125	<b>\$8,852</b>

Shelleysteel accessories and modifications can be found on pages 105-114.

### Additional Warranties

Net Pricing

One year parts and labor contract --- \$279

Two year parts and labor contract --- \$523





# SC SERIES - ALL PURPOSE COUNTERS



## Product Information

- 14-gauge stainless steel top
- 18-gauge stainless steel exterior body
- 14-gauge galvanized bottom
- Flat 14-gauge stainless steel top
- SC models are standard with dry hinged door storage compartment
- Meets NSF requirements
- All exterior panels reinforced with overlapping corners, welded in place
- All body cutouts reinforced with 14-gauge channel supports
- All units are standard on 5" diameter polyurethane swivel casters for easy cleaning
- Easy to use stainless steel interlock system is standard on base and tray slides
- Easily modified with a complete array of standard accessories
- Choose from an almost unlimited selection of laminate colors and textures to add color to any room
- Add eye catching decal packages or bright canopies to create a distinctive look!
- One year parts and 90 day labor standard warranty. Additional warranties available, see below



### SC-50-NU

Shown with the following options:  
 A. 12" stainless steel V fold down tray slide  
 G. Glass front counter protector  
 P. Open understorage with shelf

## Specifications and Prices

MODEL NUMBER	DESCRIPTION	L	D	H	SHIP WEIGHT	FREIGHT CLASS	LIST PRICE
<b>SHELLEYSSTEEL ALL PURPOSE COUNTERS</b>							
<b>With dry understorage</b>							
SC-28	dry storage	28"	30"	36"	165	125	<b>\$5,421</b>
SC-36	dry storage	36"	30"	36"	185	125	<b>\$6,267</b>
SC-50	dry storage	50"	30"	36"	205	125	<b>\$6,963</b>
SC-60	dry storage	60"	30"	36"	240	125	<b>\$7,852</b>
SC-74	dry storage	74"	30"	36"	270	125	<b>\$8,600</b>
SC-96	dry storage	96"	30"	36"	310	125	<b>\$10,099</b>
<b>Without understorage</b>							
SC-28-NU	enclosed base	28"	30"	36"	120	125	<b>\$3,524</b>
SC-36-NU	enclosed base	36"	30"	36"	160	125	<b>\$3,818</b>
SC-50-NU	enclosed base	50"	30"	36"	180	125	<b>\$4,611</b>
SC-60-NU	enclosed base	60"	30"	36"	210	125	<b>\$5,222</b>
SC-74-NU	enclosed base	74"	30"	36"	240	125	<b>\$5,963</b>
SC-96-NU	enclosed base	96"	30"	36"	280	125	<b>\$7,225</b>

Shelleysteel accessories and modifications can be found on pages 105-114.



### SC-60-NU



### Additional Warranties

Net Pricing

One year parts and labor contract --- \$279

Two year parts and labor contract --- \$523

# SCM SERIES - SHELLEYSSTEEL MILK COUNTERS

## SCF SERIES- SHELLEYSSTEEL ICE CREAM COUNTERS

### SCFM SERIES - SHELLEYSSTEEL MILK AND ICE CREAM COUNTERS



**SCM-50**

#### Product Information

- 18-gauge stainless steel exterior body
- 14-gauge galvanized bottom
- 14-gauge stainless steel top
- Top has one; two, three or four die stamped openings and is provided with hinged stainless steel removable lids
- Watertight inner liner has radius corners for easy cleaning
- Equipped with a drain plumbed to a drain valve
- Refrigerated compartment is equipped with automatic self-leveling, field adjustable elevators. Divider trays are supplied
- 60 hertz, single phase electrical standard
- 10' cord and plug standard
- Meets NSF requirements
- All exterior panels reinforced with overlapping corners, welded in place
- All body cutouts reinforced with 14-gauge channel supports
- All units are standard on 5" diameter polyurethane swivel casters for easy cleaning
- Easy to use stainless steel interlock system is standard on base and tray slides
- Easily modified with a complete array of standard accessories
- Choose from an almost unlimited selection of laminate colors and textures to add color to any room
- One year parts and 90 day labor standard warranty. Additional warranties available, see below

#### SCM SERIES ONLY

- Milk capacities are based on half pint, 2.75" x 2.75" gable top cartons

- HFC-134A refrigerant is standard

#### SCF SERIES ONLY

- Ice cream capacities are based on 3" diameter, three ounce cups

- HFC-404A refrigerant is standard

#### SCFM SERIES ONLY

- Milk capacities are based on half pint, 2.75" x 2.75" gable top cartons

- HFC-134A refrigerant is standard

#### Specifications and Prices

MODEL NUMBER	LID(S)	CAPACITY	L	D	H	AMP	H.P.	VOLTS	NEMA PLUG	SHIP WEIGHT	FREIGHT CLASS	LIST PRICE
<b>SHELLEYSSTEEL MILK COUNTERS—40°F STORAGE ONLY</b>												
SCM-36	1	126 cartons	36"	30"	36"	5.0	1/4	115	5-15P	400	92.5	<b>\$9,633</b>
SCM-50	2	252 cartons	50"	30"	36"	5.0	1/4	115	5-15P	450	92.5	<b>\$13,404</b>
SCM-60	3	378 cartons	60"	30"	36"	5.0	1/4	115	5-15P	500	92.5	<b>\$15,671</b>
SCM-74	4	504 cartons	74"	30"	36"	5.0	1/4	115	5-15P	550	92.5	<b>\$18,285</b>
<b>SHELLEYSSTEEL ICE CREAM COUNTERS—0°F STORAGE ONLY</b>												
SCF-36	1	210 cups	36"	30"	36"	7.1	1/4	115	5-15P	475	92.5	<b>\$13,269</b>
SCF-50	2	420 cups	50"	30"	36"	7.1	1/4	115	5-15P	525	92.5	<b>\$15,954</b>
SCF-60	3	630 cups	60"	30"	36"	8.0	1/3	115	5-15P	575	92.5	<b>\$18,270</b>
SCF-74	4	840 cups	74"	30"	36"	8.0	1/3	115	5-15P	625	92.5	<b>\$20,745</b>
<b>SHELLEYSSTEEL MILK AND ICE CREAM COUNTERS—40°F AND 0°F STORAGE ONLY</b>												
SCFM-50	2	126 cartons or 210 cups	50"	30"	36"	7.1	1/4	115	5-15P	500	92.5	<b>\$16,728</b>
SCFM-74	4	252 cartons or 420 cups	74"	30"	36"	8.0	1/3	115	5-15P	590	92.5	<b>\$21,754</b>

Shelleysteel accessories and modifications can be found on pages 105-114.

#### Additional Warranties

Net Pricing

One year parts and labor contract --- \$279

Two year parts and labor contract -- \$523

Five year compressor warranty

1/4 H.P. ----- \$108

1/3 H.P. ----- \$128



# SCS SERIES - CASHIER'S COUNTER SCTRI SERIES - TRIANGLE CORNER COUNTER SRB SERIES - CARVING COUNTER SCTS SERIES - TRAY STANDS SWT SERIES - WORK TABLES



## Product Information

- 18-gauge stainless steel exterior body
- 14-gauge galvanized bottom
- 14-gauge stainless steel top
- Meets NSF requirements
- All exterior panels reinforced with overlapping corners, welded in place
- All body cutouts reinforced with 14-gauge channel supports
- All units are standard on 5" diameter polyurethane swivel casters for easy cleaning
- Easy to use stainless steel interlock system is standard on base and tray slides
- Easily modified with a complete array of standard accessories
- Choose from an almost unlimited selection of laminate colors and textures to add color to any room
- One year parts and 90 day labor standard warranty. Additional warranties available, see below

### SCS SERIES ONLY

- A 3" grommet hole is located at the rear of the top to allow cord access for cash registers
- Stainless steel locking cash drawer standard
- Stainless steel under shelf can serve as foot rest or storage

### SRB SERIES ONLY

- SRB counters are standard with stainless steel removable carving tray, heated au jus well, non-adjustable infrared heat lamp, dry under storage compartment with hinged doors
- 10' cord and plug are standard
- 50 Hertz, single phase electrical standard
- SRB models are standard with dry hinged door storage compartment with shelf
- Electrical accessories may change listed amperage and plug

### SCTS SERIES ONLY

- Silverware cutouts and cylinders are optional



### SCS-30

Shown with the following options:  
A. 12" stainless steel V fold down tray slide  
Q. outlet with breaker



### SCTS-28

Shown with the following option:  
SW. silverware cutouts with stainless steel silverware holder

## Specifications and Prices

MODEL NUMBER	DESCRIPTION	L	D	H	AMP	VOLTS	NEMA PLUG	SHIP WEIGHT	FREIGHT CLASS	LIST PRICE
<b>SHELLEYSTEEL CASHIER'S COUNTERS</b>										
SCS-30	cashier's counter	30"	30"	36"	N/A	N/A	N/A	180	100	\$4,473
SCS-36	cashier's counter	30"	36"	36"	N/A	N/A	N/A	210	100	\$4,800
SCS-50	cashier's counter	30"	50"	36"	N/A	N/A	N/A	270	100	\$5,160
<b>SHELLEYSTEEL TRIANGLE CORNER UNIT</b>										
SC-TRI	corner unit, enclosed base	40"	30"	36"	N/A	N/A	N/A	160	100	\$4,778
SC-TRIOS	corner unit, open shelf	40"	30"	36"	N/A	N/A	N/A	160	100	\$5,227
<b>SHELLEYSTEEL CARVING COUNTERS</b>										
SRB	carving counter	28"	30"	36"	5.0	120	5-15P	180	100	\$10,305
<b>SHELLEYSTEEL TRAY STANDS</b>										
SCTS-28	tray stand	30"	28"	36"	N/A	N/A	N/A	150	125	\$3,386
SCTS-36	tray stand	30"	36"	36"	N/A	N/A	N/A	192	125	\$3,545
<b>SHELLEYSTEEL WORK TABLES</b>										
SWT-36	work table	36"	30"	36"	N/A	N/A	N/A	100	125	\$3,452
SWT-48	work table	48"	30"	36"	N/A	N/A	N/A	158	125	\$3,590
SWT-60	work table	60"	30"	36"	N/A	N/A	N/A	200	125	\$3,767
SWT-74	work table	74"	30"	36"	N/A	N/A	N/A	230	125	\$3,931

Shelleysteel accessories and modifications can be found on pages 105-114.

**Additional Warranties**  
Net Pricing  
One year parts and labor contract --- \$279  
  
Two year parts and labor contract --- \$523

# KH SERIES - MOBILE HEATED SERVING COUNTERS



### KH-4-NU

Shown with the following option:  
G. glass front counter protector  
P. open shelf understorage



### KH-5-NU

Shown with the following options:  
KS. single service sneeze guard  
A. 12" stainless steel V fold-down tray slide  
V. 6" Adjustable bullet feet



Add eye catching decal packages or bright canopies to create a distinctive look!

## Product Information

- One piece, molded fiberglass pylon (base), fully rounded corners, permanent color
- All corners and center sides reinforced with galvanized bracing, laminated into the fiberglass
- Full NSF and UL Certification
- Fire Code rating on fiberglass, laminate, canopy materials
- 14-gauge tops
- All units are standard on 5" diameter polyurethane swivel casters for easy cleaning
- Caster mounting plates laminated into base
- Easy to use stainless steel interlock system is standard on base and tray slides
- Enclosed bases for vermin control
- A maximum 10' long cord and plug are supplied standard
- KH units have heated under storage compartment, provided with removable pan slides. KH-NU units have enclosed bases with no under storage
- Electrical connections are 60 hertz, single phase. Three-phase design is available for an additional charge. Electrical accessories may change listed amperage and plug
- Top has two to six electrically heated, recessed die stamped stainless steel hot food warmers. Each warmer accommodates one 12" x 20" x 6" pan
- All body cutouts reinforced with 14-gauge channel supports
- Easily modified with a complete array of standard accessories
- Counter heights available from 28" to 36" in 2" increments
- Choose from 25 standard fiberglass colors, custom colors are also available
- Add eye catching decal packages or bright canopies to create a distinctive look!
- Features new easy access panel for quick replacement of heating element.
- Contact Delfield for a Shelleyglas color chart or visit [www.delfield.com](http://www.delfield.com)
- One year parts and 90 day labor standard warranty. Additional warranties available, see below

## Specifications and Prices

MODEL NUMBER	DESCRIPTION	OVERALL			AMP	VOLTS	MAX WATTS	NEMA PLUG	SHIP WEIGHT	FREIGHT CLASS	LIST PRICE
		L	D	H							
<b>SHELLEYGLAS HEATED SERVING COUNTERS</b>											
<b>With heated understorage</b>											
<b>KH-2</b>	2 food wells	36"	30"	36"	15.0	120/208-230	2900/3300	14-20P	380	100	<b>\$9,688</b>
<b>KH-3</b>	3 food wells	50"	30"	36"	20.0	120/208-230	3900/4500	14-30P	460	100	<b>\$10,906</b>
<b>KH-4</b>	4 food wells	60"	30"	36"	26.0	120/208-230	4900/5700	14-50P	550	100	<b>\$11,883</b>
<b>KH-5</b>	5 food wells	74"	30"	36"	31.0	120/208-230	5900/6900	14-50P	660	100	<b>\$13,048</b>
<b>KH-6</b>	6 food wells	96"	30"	36"	37.0	120/208-230	6900/7900	14-50P	720	100	<b>\$14,886</b>
<b>Without understorage</b>											
<b>KH-2-NU</b>	2 food wells	36"	30"	36"	11.0	120/208-230	2000/2400	14-20P	225	100	<b>\$6,680</b>
<b>KH-3-NU</b>	3 food wells	50"	30"	36"	16.0	120/208-230	3000/3600	14-20P	275	100	<b>\$7,510</b>
<b>KH-4-NU</b>	4 food wells	60"	30"	36"	22.0	120/208-230	4000/4800	14-30P	330	100	<b>\$8,463</b>
<b>KH-5-NU</b>	5 food wells	74"	30"	36"	28.0	120/208-230	5000/6000	14-50P	420	100	<b>\$9,598</b>
<b>KH-6-NU</b>	6 food wells	96"	30"	36"	33.0	120/208-230	6000/7000	14-50P	510	100	<b>\$11,410</b>

Shelleyglas accessories and modifications can be found on pages 105-114.

**Additional Warranties**  
Net Pricing  
One year parts and labor contract --- \$279  
  
Two year parts and labor contract --- \$523



# KCSC-B SERIES - MOBILE REFRIGERATED COLD PAN SERVING COUNTERS

## KCSC-EF SERIES - LIQUITEC REFRIGERATED COLD PAN



### Product Information

- One piece, molded fiberglass pylon (base), fully rounded corners, permanent color
- All corners and center sides reinforced with galvanized bracing, laminated into the fiberglass
- Full NSF and UL Certification
- Fire Code rating on fiberglass, laminate, canopy materials
- 14-gauge tops
- All units are standard on 5" diameter polyurethane swivel casters for easy cleaning
- Caster mounting plates laminated into base
- Easy to use stainless steel interlock system is standard on base and tray slides
- Enclosed bases for vermin control
- A maximum 10' long cord and plug are supplied standard
- Uses environmentally friendly R404A refrigerant
- Easy to use stainless steel interlock system is standard on base and tray slides
- Easily modified with a complete array of standard accessories
- Electrical connections are 60 hertz, single phase. Electrical accessories may change listed amperage and plug
- Counter heights available from 28" to 36" in 2" increments
- Unit has on/off switch mounted on the exterior
- Add eye catching decal packages or bright canopies to create a distinctive look!
- Contact Delfield for a Shelleyglas color chart or visit [www.delfield.com](http://www.delfield.com)

- One year parts and 90 day labor standard warranty. Additional warranties available, see below
- All body cutouts reinforced with 14-gauge channel supports

#### KCSC-B SERIES ONLY

- KCSC-B Series counters are standard with 7" deep refrigerated cold pan. Cold pans are fully insulated with foamed in place polyurethane insulation
- Pans recessed 2" from top edge of counter
- Cold pans are standard with drain with valve
- Adapter bars will be furnished at no additional charge if requested on original order only. Pans are supplied by others
- Optional open shelf and dry door inserts can be added to all models and lengths. Refrigerated insert can be added to 60", 74", or 96" long units

#### KCSC-EF SERIES ONLY

- The LiquiTec cold pan has two – six die stamped openings with depressed edges in each well, holding one 12" x 20" pan (pans supplied by others)
- Eutectic fluid completely surrounds each cold pan providing the maximum-- five sided cooling
- All KCSC-EF models meet NSF 7 with pans completely flush with counter
- Cold pan is fully insulated with foamed in place polyurethane insulation



#### KCSC-50-B

- Shown with the following options:
- HD. double-service two-tier display
  - A. 12" stainless steel V fold down tray slide
  - V. 6" adjustable bullet feet

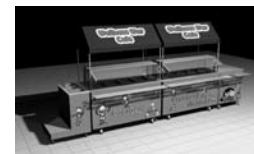

Add eye catching decal packages or bright canopies to create a distinctive look!



Patented LiquiTec® Technology brings food and pans completely flush!



### Specifications and Prices

MODEL NUMBER	COLD PAN SIZE	DIMENSIONS			AMP	H.P.	VOLTS	NEMA PLUG	SHIP WEIGHT	FREIGHT CLASS	LIST PRICE
		L	D	H							
<b>SHELLEYGLAS REFRIGERATED COLD PAN SERVING COUNTERS</b>											
<b>KCSC-36-B</b>	26" x 21.62"	36"	30"	36"	7.0	1/4	115	5-15P	350	100	<b>\$9,799</b>
<b>KCSC-50-B</b>	39" x 21.62"	50"	30"	36"	7.0	1/4	115	5-15P	425	100	<b>\$10,180</b>
<b>KCSC-60-B</b>	52" x 21.62"	60"	30"	36"	7.0	1/4	115	5-15P	500	100	<b>\$10,696</b>
<b>KCSC-74-B</b>	65" x 21.62"	74"	30"	36"	7.0	1/4	115	5-15P	575	110	<b>\$13,319</b>
<b>KCSC-96-B</b>	78" x 21.62"	96"	30"	36"	7.0	1/4	115	5-15P	650	110	<b>\$15,076</b>

#### SHELLEYGLAS WITH PATENTED LiquiTec® TECHNOLOGY

<b>KCSC-36-EF</b>	2 pan cap	36"	30"	36"	7.0	1/4	115	5-15P	380	100	<b>\$11,198</b>
<b>KCSC-50-EF</b>	3 pan cap	50"	30"	36"	7.0	1/4	115	5-15P	455	100	<b>\$11,633</b>
<b>KCSC-60-EF</b>	4 pan cap	60"	30"	36"	7.0	1/4	115	5-15P	530	100	<b>\$12,226</b>
<b>KCSC-74-EF</b>	5 pan cap	74"	30"	36"	7.0	1/4	115	5-15P	615	100	<b>\$15,980</b>
<b>KCSC-96-EF</b>	6 pan cap	96"	30"	36"	7.0	1/4	115	5-15P	680	100	<b>\$16,449</b>

Shelleyglas accessories and modifications can be found on pages 105-114.

Additional Warranties Net Pricing
One year parts and labor contract --- \$279
Two year parts and labor contract -- \$523
Five year compressor warranty 1/4 H.P. ----- \$108





# KHCR-B SERIES - HOT/COLD COMBINATION COUNTERS

## KHC-NU SERIES - ICE COOLED HOT/COLD COMBINATION COUNTERS



**KHCR-50B**

Shown with the following options:  
 A. 12" stainless steel V fold down tray slide  
 V. 6" adjustable bullet feet



**KHCR2-96-B**

Shown with the following option:  
 KD. double service flip up sneeze guard



**KHC-60-NU**

Shown with the following option:  
 A. 12" stainless steel V fold down tray slide  
 HD. double service two tier display  
 V. 6" adjustable bullet feet

### Product Information

- Save space by having both hot and cold in one convenient location
- One piece, molded fiberglass pylon (base), fully rounded corners, permanent color
- All corners and center sides reinforced with galvanized bracing, laminated into the fiberglass
- Full NSF and UL Certification
- Fire Code rating on fiberglass, laminate, canopy materials
- 14-gauge tops
- All units are standard on 5" polyurethane swivel casters for easy cleaning
- Caster mounting plates laminated into base
- Easy to use stainless steel interlock system is standard on base and tray slides
- A maximum 10' long cord and plug are supplied standard
- All KHCR-B and KHC models are standard with enclosed bases
- Top has one to four electrically heated, recessed die-stamped stainless steel hot food warmers. Each warmer accommodates a 12" x 20" x 6" pan (pans supplied by others)
- Note: When lights with heat lamps are used over hot wells, incandescent light fixtures will be used due to heat
- Electrical connections are 60 hertz, single phase. Three-phase design is available for an additional charge. Electrical accessories may change listed amperage and plug
- All body cutouts reinforced with 14-gauge channel supports
- Easily modified with a complete array of standard accessories
- Counter heights available from 28" to 36" in 2" increments
- Add eye catching decal packages or bright canopies to create a distinctive look!
- Contact Delfield for a Shelleyglas color chart or visit [www.delfield.com](http://www.delfield.com)
- One year parts and 90 day labor standard warranty. Additional warranties available, see below

#### KHCR-B ONLY

- The refrigerated cold pan is 7" deep constructed of stainless steel. Cold pan is equipped with a 1" drain with valve
- Meets NSF requirements with pans recessed 3"
- Environmentally friendly HFC-404A refrigerant

#### KHC-NU ONLY

- Insulated ice pan is 7" deep and constructed of 22-gauge stainless steel. Perforated false bottom, and drain with valve is standard

### Specifications and Prices

MODEL NUMBER	HOT WELLS	COLD PAN SIZE	DIMENSIONS			AMP	H.P.	VOLTS	NEMA PLUG	SHIP WEIGHT	FREIGHT CLASS	LIST PRICE
			L	D	H							
<b>SHELLEYGLAS SELF-CONTAINED HOT AND COLD COMBINATION COUNTERS</b>												
<b>KHCR-50-B</b>	1	26" X 21.62"	50"	30"	36"	16.0	1/4	120	5-20P	475	100	<b>\$10,931</b>
<b>KHCR-60-B</b>	1	26" X 21.62"	60"	30"	36"	16.0	1/4	120	5-20P	575	100	<b>\$11,533</b>
<b>KHCR-74-B</b>	1	39" X 21.62"	74"	30"	36"	16.0	1/4	120	5-20P	688	100	<b>\$12,890</b>
<b>KH2CR-74-B</b>	2	26" X 21.62"	74"	30"	36"	18.0	1/4	120/208-230	14-30P	690	100	<b>\$13,840</b>
<b>KHCR-96-B</b>	1	65" X 21.62"	96"	30"	36"	16.0	1/4	120	5-20P	730	100	<b>\$15,745</b>
<b>KH2CR-96-B</b>	2	52" X 21.62"	96"	30"	36"	18.0	1/4	120/208-230	14-30P	740	100	<b>\$16,723</b>
<b>KH3CR-96-B</b>	3	39" X 21.62"	96"	30"	36"	23.0	1/4	120/208-230	14-30P	750	100	<b>\$17,538</b>
<b>KH4CR-96-B</b>	4	26" X 21.62"	96"	30"	36"	29.0	1/4	120/208-230	14-50P	760	100	<b>\$18,701</b>

Shelleyglas accessories and modifications can be found on pages 105-114.

### Specifications and Prices

MODEL NUMBER	HOT WELLS	COLD PAN SIZE	OVERALL			H.P.	AMP	VOLTS	NEMA PLUG	SHIP WEIGHT	FREIGHT CLASS	LIST PRICE
			L	D	H							
<b>SHELLEYGLAS ICE-COOLED HOT AND COLD COMBINATION COUNTERS</b>												
<b>KHC-50-NU</b>	1	26" X 21.62"	50"	30"	36"	—	9.0	120	5-15P	300	100	<b>\$7,848</b>
<b>KHC-60-NU</b>	1	39" X 21.62"	60"	30"	36"	—	9.0	120	5-15P	350	100	<b>\$8,624</b>
<b>KHC-74-NU</b>	1	52" X 21.62"	74"	30"	36"	—	9.0	120	5-15P	400	100	<b>\$10,071</b>
<b>KH2C-74-NU</b>	2	26" X 21.62"	74"	30"	36"	—	11.0	120/208-230	14-20P	410	100	<b>\$11,032</b>
<b>KHC-96-NU</b>	1	65" X 21.62"	96"	30"	36"	—	9.0	120	5-15P	425	100	<b>\$12,816</b>
<b>KH2C-96-NU</b>	2	52" X 21.62"	96"	30"	36"	—	11.0	120/208-230	14-20P	430	100	<b>\$13,815</b>
<b>KH3C-96-NU</b>	3	39" X 21.62"	96"	30"	36"	—	16.0	120/208-230	14-20P	450	100	<b>\$14,765</b>
<b>KH4C-96-NU</b>	4	26" X 21.62"	96"	30"	36"	—	22.0	120/208-230	14-30P	460	100	<b>\$15,973</b>

Shelleyglas accessories and modifications can be found on pages 105-114.

SHELLEYGLAS® SERVING LINES

#### Additional Warranties

Net Pricing

One year parts and labor contract --- \$279

Two year parts and labor contract -- \$523

Five year compressor warranty  
 1/4 H.P. ----- \$108



# KCFT-NU SERIES - FROST TOP SERVING COUNTERS



**KCFT-60-NU**

## Product Information

- One piece, molded fiberglass pylon (base), fully rounded corners, permanent color
- All corners and center sides reinforced with galvanized bracing, laminated into the fiberglass
- Full NSF and UL Certification
- Fire Code rating on fiberglass, laminate, canopy materials
- 14-gauge tops
- All units are standard on 5" diameter polyurethane swivel casters for easy cleaning
- Caster mounting plates laminated into base
- Easy to use stainless steel interlock system is standard on base and tray slides
- Enclosed bases for vermin control
- A maximum 10' long cord and plug are supplied standard
- Frost top is 18-gauge stainless steel, one piece construction; perimeter drain with valve located at bottom of unit standard
- 18"x 26" sheet pan can rest on frost top
- On/off switch located on exterior of unit
- Electrical connections are 60 hertz, single phase. Electrical accessories may change listed amperage and plug
- All body cutouts reinforced with 14-gauge channel supports
- Easily modified with a complete array of standard accessories
- Counter heights available from 28" to 36"
- Add eye catching decal packages or bright canopies to create a distinctive look!
- Environmentally friendly R404A refrigerant
- Contact Delfield for a Shelleyglas color chart or visit [www.delfield.com](http://www.delfield.com)
- One year parts and 90 day labor standard warranty. Additional warranties available, see below

## Specifications and Prices

MODEL NUMBER	DESCRIPTION	OVERALL			AMP	H.P.	VOLTS	NEMA PLUG	SHIP WEIGHT	FREIGHT CLASS	LIST PRICE
		L	D	H							
<b>SHELLEYGLAS FROST TOP SERVING COUNTERS</b>											
<b>Without understorage</b>											
<b>KCFT-36-NU</b>	frost top	36"	30"	36"	7.0	1/4	115	5-15P	380	100	<b>\$9,841</b>
<b>KCFT-50-NU</b>	frost top	50"	30"	36"	7.0	1/4	115	5-15P	455	100	<b>\$11,032</b>
<b>KCFT-60-NU</b>	frost top	60"	30"	36"	7.0	1/4	115	5-15P	540	100	<b>\$12,311</b>
<b>KCFT-74-NU</b>	frost top	74"	30"	36"	8.0	1/4	115	5-15P	610	110	<b>\$13,180</b>
<b>KCFT-96-NU</b>	frost top	96"	30"	36"	8.0	1/4	115	5-15P	680	110	<b>\$15,069</b>

Shelleyglas accessories and modifications can be found on pages 105-114.

<b>Additional Warranties</b>
Net Pricing
One year parts and labor contract --- \$279
Two year parts and labor contract -- \$523
Five year compressor warranty 1/4 H.P. ----- \$108



# KCI SERIES - ICE PAN SERVING COUNTERS



### KCI-50-NU

Shown with the following options:

- E. fold down workshelf
- H. two tier display

P. open understorage with shelf

## Product Information

- Best for use where electricity is not available
- One piece, molded fiberglass pylon (base), fully rounded corners, permanent color
- All corners and center sides reinforced with galvanized bracing, laminated into the fiberglass
- Full NSF and UL Certification
- Fire Code rating on fiberglass, laminate, canopy materials
- 14-gauge tops
- All units are standard on 5" diameter polyurethane swivel casters for easy cleaning
- Caster mounting plates laminated into base
- Easy to use stainless steel interlock system is standard on base and tray slides
- Insulated ice pan is 7" deep and is standard with the following: perforated false bottom, drain with valve and casters
- KCI units are standard with dry hinged door storage compartment, while KCI-NU units have enclosed bases with no understorage
- All body cutouts reinforced with 14-gauge channel supports
- Easily modified with a complete array of standard accessories
- Add eye catching decal packages or bright canopies to create a distinctive look!
- Contact Delfield for a Shelleyglas color chart or visit [www.delfield.com](http://www.delfield.com)
- One year parts and 90 day labor standard warranty. Additional warranties available, see below

## Specifications and Prices

MODEL NUMBER	ICE PAN SIZE	L	DIMENSIONS D H		SHIP WEIGHT	FREIGHT CLASS	LIST PRICE
<b>SHELLEYGLAS ICE PAN SERVING COUNTERS</b>							
<b>With dry understorage</b>							
KCI-36	26" x 21.62"	36"	30"	36"	240	110	<b>\$7,919</b>
KCI-50	39" x 21.62"	50"	30"	36"	285	110	<b>\$8,414</b>
KCI-60	52" x 21.62"	60"	30"	36"	320	110	<b>\$9,373</b>
KCI-74	65" x 21.62"	74"	30"	36"	360	110	<b>\$10,344</b>
KCI-96	78" x 21.62"	96"	30"	36"	400	110	<b>\$12,003</b>
<b>Without understorage</b>							
KCI-36-NU	26" x 21.62"	36"	30"	36"	200	110	<b>\$5,437</b>
KCI-50-NU	39" x 21.62"	50"	30"	36"	245	110	<b>\$6,003</b>
KCI-60-NU	52" x 21.62"	60"	30"	36"	280	110	<b>\$7,185</b>
KCI-74-NU	65" x 21.62"	74"	30"	36"	330	110	<b>\$7,945</b>
KCI-96-NU	78" x 21.62"	96"	30"	36"	380	110	<b>\$8,220</b>

Shelleyglas accessories and modifications can be found on pages 105-114.

### Additional Warranties Net Pricing

One year parts and labor contract --- \$279

Two year parts and labor contract -- \$523





# KCU SERIES - BEVERAGE COUNTERS



## Product Information

- One piece, molded fiberglass pylon (base), fully rounded corners, permanent color
- All corners and center sides reinforced with galvanized bracing, laminated into the fiberglass
- Full NSF and UL Certification
- Fire Code rating on fiberglass, laminate, canopy materials
- 14-gauge tops
- All units are standard on 5" diameter polyurethane swivel casters for easy cleaning
- Caster mounting plates laminated into base
- A maximum 10' long cord and plug are supplied standard
- Reinforced top includes a stainless steel drain trough with removable stainless steel anti-splash drip gate. (Trough is standard on customer side, available on operator side if specified.)
- KCU models are standard with dry hinged door storage compartment
- All body cutouts reinforced with 14-gauge channel supports
- Easy to use stainless steel interlock system is standard on base and tray slides
- Easily modified with a complete array of standard accessories
- Add eye catching decal packages or bright canopies to create a distinctive look!
- Contact Delfield for a Shelleyglas color chart or visit [www.delfield.com](http://www.delfield.com)
- One year parts and 90 day labor standard warranty. Additional warranties available, see below



### KCU-36-NU

Shown with the following option:  
A. 12" stainless steel V fold down tray slide

## Specifications and Prices

MODEL NUMBER	DESCRIPTION	L	D	H	SHIP WEIGHT	FREIGHT CLASS	LIST PRICE
<b>SHELLEYGLAS BEVERAGE COUNTERS</b>							
<b>With dry understorage</b>							
KCU-36	24" urn trough	36"	30"	36"	200	125	<b>\$6,364</b>
KCU-50	36" urn trough	50"	30"	36"	230	125	<b>\$7,261</b>
KCU-60	48" urn trough	60"	30"	36"	270	125	<b>\$7,880</b>
KCU-74	60" urn trough	74"	30"	36"	300	125	<b>\$8,824</b>
KCU-96	82" urn trough	96"	30"	36"	340	125	<b>\$10,324</b>
<b>Without understorage</b>							
KCU-36-NU	24" urn trough	36"	30"	36"	170	125	<b>\$4,503</b>
KCU-50-NU	36" urn trough	50"	30"	36"	190	125	<b>\$4,941</b>
KCU-60-NU	48" urn trough	60"	30"	36"	230	125	<b>\$5,536</b>
KCU-74-NU	60" urn trough	74"	30"	36"	260	125	<b>\$6,366</b>
KCU-96-NU	82" urn trough	96"	30"	36"	300	125	<b>\$7,827</b>

Shelleyglas accessories and modifications can be found on pages 105-114.

<p><b>Additional Warranties</b> Net Pricing One year parts and labor contract --- \$279  Two year parts and labor contract -- \$523</p>
---



# KC SERIES - ALL PURPOSE COUNTERS



**KC-28-NU**

Shown with the following options:  
 C. tubular fold down trayslide  
 P. open understorage with shelf

## Product Information

- One piece, molded fiberglass pylon (base), fully rounded corners, permanent color
- All corners and center sides reinforced with galvanized bracing, laminated into the fiberglass
- Full NSF and UL Certification
- Fire Code rating on fiberglass, laminate, canopy materials
- All units are standard on 5" diameter polyurethane swivel casters for easy cleaning
- Caster mounting plates laminated into base
- Enclosed bases for vermin control
- Flat 14-gauge stainless steel top
- KC models are standard with dry hinged door storage compartment
- Easy to use stainless steel interlock system is standard on base and tray slides
- Easily modified with a complete array of standard accessories
- Add eye catching decal packages or bright canopies to create a distinctive look!
- Contact Delfield for a Shelleyglas color chart or visit [www.delfield.com](http://www.delfield.com)
- One year parts and 90 day labor standard warranty. Additional warranties available, see below



**KC-50-NU**

Shown with the following options:  
 A. 12" stainless steel V fold down tray slide  
 G. glass front counter protector

## Specifications and Prices

MODEL NUMBER	DESCRIPTION	L	D	H	SHIP WEIGHT	FREIGHT CLASS	LIST PRICE
<b>SHELLEYGLAS ALL PURPOSE COUNTERS</b>							
<b>With dry understorage</b>							
<b>KC-28</b>	dry storage	28"	30"	36"	165	125	<b>\$5,036</b>
<b>KC-36</b>	dry storage	36"	30"	36"	185	125	<b>\$5,822</b>
<b>KC-50</b>	dry storage	50"	30"	36"	205	125	<b>\$6,470</b>
<b>KC-60</b>	dry storage	60"	30"	36"	240	125	<b>\$7,296</b>
<b>KC-74</b>	dry storage	74"	30"	36"	270	125	<b>\$7,973</b>
<b>KC-96</b>	dry storage	96"	30"	36"	310	125	<b>\$9,373</b>
<b>Without understorage</b>							
<b>KC-28-NU</b>	enclosed base	28"	30"	36"	120	125	<b>\$3,407</b>
<b>KC-36-NU</b>	enclosed base	36"	30"	36"	160	125	<b>\$3,617</b>
<b>KC-50-NU</b>	enclosed base	50"	30"	36"	180	125	<b>\$4,274</b>
<b>KC-60-NU</b>	enclosed base	60"	30"	36"	210	125	<b>\$4,853</b>
<b>KC-74-NU</b>	enclosed base	74"	30"	36"	240	125	<b>\$5,539</b>
<b>KC-96-NU</b>	enclosed base	96"	30"	36"	280	125	<b>\$6,716</b>

Shelleyglas accessories and modifications can be found on pages 105-114.



**KC-74-NU**

Shown with optional canopy, sandwich slide and trayslide

### Additional Warranties

Net Pricing

One year parts and labor contract --- \$279

Two year parts and labor contract -- \$523



# KCM SERIES - MILK COUNTERS KCF SERIES - ICE CREAM COUNTERS KCFM SERIES - MILK AND ICE CREAM COUNTERS



## Product Information

- One piece, molded fiberglass pylon (base), fully rounded corners, permanent color
- All corners and center sides reinforced with galvanized bracing, laminated into the fiberglass
- Full NSF and UL Certification
- Fire Code rating on fiberglass, laminate, canopy materials
- 14-gauge tops
- All units are standard on 5" diameter polyurethane swivel casters for easy cleaning
- Caster mounting plates laminated into base
- Easy to use stainless steel interlock system is standard on base and tray slides
- Enclosed bases for vermin control
- A maximum 10' long cord and plug are supplied standard
- Top has one; two, three or four die stamped openings and is provided with hinged stainless steel removable lids
- Watertight inner liner has radius corners for easy cleaning
- Equipped with a drain plumbed to a drain valve
- Refrigerated compartment is equipped with automatic self-leveling, field adjustable elevators. Divider trays are supplied

- Milk capacities are based on half pint, 2.75" x 2.75" gable top cartons
- 60 hertz, single phase electrical standard
- All body cutouts reinforced with 14-gauge channel supports
- Easy to use interlock system is standard on base and tray slides
- Easily modified with a complete array of standard accessories
- Add eye catching decal packages to create a distinctive look!
- Contact Delfield for a Shelleyglas color chart or visit [www.delfield.com](http://www.delfield.com)
- One year parts and 90 day labor standard warranty. Additional warranties available, see below

### KCM SERIES ONLY

- HFC-134A refrigerant is standard

### KCF SERIES ONLY

- Environmentally friendly R404A refrigerant

### KCFM SERIES ONLY

- HFC-134A refrigerant is standard



**KCM-50**  
Shown with the following option:  
C. tubular fold down tray slide



**KCFM-50**

## Specifications and Prices

MODEL NUMBER	LID(S)	DESCRIPTION	L	D	H	AMP	H.P.	VOLTS	NEMA PLUG	SHIP WEIGHT	FREIGHT CLASS	LIST PRICE
<b>SHELLEYGLAS MILK COUNTERS—40°F STORAGE ONLY</b>												
<b>KCM-36</b>	1	126 cartons	36"	30"	36"	5.0	1/4	115	5-15P	400	92.5	<b>\$11,950</b>
<b>KCM-50</b>	2	252 cartons	50"	30"	36"	5.0	1/4	115	5-15P	450	92.5	<b>\$13,846</b>
<b>KCM-60</b>	3	378 cartons	60"	30"	36"	5.0	1/4	115	5-15P	500	92.5	<b>\$15,264</b>
<b>KCM-74</b>	4	504 cartons	74"	30"	36"	5.0	1/4	115	5-15P	550	92.5	<b>\$17,796</b>
<b>SHELLEYGLAS ICE CREAM COUNTERS—0°F STORAGE ONLY</b>												
<b>KCF-36</b>	1	210 cups	36"	30"	36"	7.1	1/4	115	5-15P	475	92.5	<b>\$12,892</b>
<b>KCF-50</b>	2	420 cups	50"	30"	36"	7.1	1/4	115	5-15P	525	92.5	<b>\$15,171</b>
<b>KCF-60</b>	3	630 cups	60"	30"	36"	8.0	1/3	115	5-15P	575	92.5	<b>\$17,134</b>
<b>KCF-74</b>	4	840 cups	74"	30"	36"	8.0	1/3	115	5-15P	625	92.5	<b>\$19,712</b>
<b>SHELLEYGLAS MILK AND ICE CREAM COUNTERS—40°F AND 0°F STORAGE ONLY</b>												
<b>KCFM-50</b>	2	126 cartons or 210 cup	50"	30"	36"	7.1	1/4	115	5-15P	500	92.5	<b>\$15,860</b>
<b>KCFM-74</b>	4	252 cartons or 420 cups	74"	30"	36"	8.0	1/3	115	5-15P	590	92.5	<b>\$20,630</b>

Shelleyglas accessories and modifications can be found on pages 105-114.

Additional Warranties	
Net Pricing	
One year parts and labor contract ---	\$279
Two year parts and labor contract --	\$523
Five year compressor warranty	
1/4 H.P. -----	\$108
1/3 H.P. -----	\$128



**KCS SERIES - CASHIER'S COUNTERS**  
**KRB SERIES - CARVING COUNTERS**  
**KCTS SERIES - TRAY STANDS**  
**PWT SERIES - WORK TABLES**



**Product Information**



**KCS-36**

Shown with the following option:  
 (2) E. 10" stainless steel fold-down work shelves (being used as tray slides)



**KRB**

Shown with the following options:  
 F. line-up interlock device  
 A. 12" stainless steel V fold-down tray slide



**PWT-60**

- One piece, molded fiberglass pylon (base), fully rounded corners, permanent color
- All corners and center sides reinforced with galvanized bracing, laminated into the fiberglass
- 14-gauge tops
- Full NSF and UL Certification
- Fire Code rating on fiberglass, laminate, canopy materials
- All units are standard on 5" diameter polyurethane swivel casters for easy cleaning
- Caster mounting plates laminated into base
- Easy to use stainless steel interlock system is standard on base and tray slides
- Easily modified with a complete array of standard accessories
- All body cutouts reinforced with 14-gauge channel supports
- Contact Delfield for a Shelleyglas color chart or visit [www.delfield.com](http://www.delfield.com)
- One year parts and 90 day labor standard warranty. Additional warranties available, see below

- All body cutouts reinforced with 14-gauge channel supports
- Add eye catching decal packages or bright canopies to create a distinctive look!

**KRB SERIES ONLY**

- Enclosed bases for vermin control
- A maximum 10' long cord and plug are supplied standard
- KRB counters are standard with stainless steel removable carving tray, heated au jus well, non-adjustable infrared heat lamp, dry under storage compartment with hinged doors
- 10' cord and plug are standard
- KRB models are standard with dry hinged door storage compartment with shelf
- Electrical accessories may change listed amperage and plug

**KCTS SERIES ONLY**

- All units are standard on 5" diameter swivel casters for easy cleaning and mobility
- Caster mounting plates laminated into base
- Easy to use interlock system is standard on base and tray slides
- 14-gauge stainless steel top and tray step down
- Silverware cutouts and cylinders are optional

**KCS SERIES ONLY**

- A 3" grommet hole is located at the rear of the top to allow cord access for cash registers
- Stainless steel locking cash drawer standard
- Stainless steel under shelf can serve as foot rest or storage

**Specifications and Prices**

MODEL NUMBER	DESCRIPTION	L	D	H	AMP	VOLTS	NEMA PLUG	SHIP WEIGHT	FREIGHT CLASS	LIST PRICE
<b>SHELLEYGLAS CASHIER'S COUNTERS</b>										
KCS-30	cashier's counter	30"	30"	36"	N/A	N/A	N/A	180	100	\$4,146
KCS-36	cashier's counter	30"	36"	36"	N/A	N/A	N/A	210	100	\$4,457
KCS-50	cashier's counter	30"	50"	36"	N/A	N/A	N/A	270	100	\$5,118
<b>SHELLEYGLAS CARVING COUNTERS</b>										
KRB	carving counter	28"	30"	36"	5.0	120	5-15P	180	100	\$8,944
<b>SHELLEYGLAS TRAY STANDS</b>										
KCTS-28	tray stand	30"	28"	36"	N/A	N/A	N/A	150	125	\$3,149
KCTS-36	tray stand	30"	36"	36"	N/A	N/A	N/A	192	125	\$3,283
<b>SHELLEYGLAS WORK TABLES</b>										
PWT-36	work table	36"	30"	36"	N/A	N/A	N/A	100	125	\$3,247
PWT-48	work table	48"	30"	36"	N/A	N/A	N/A	158	125	\$3,576
PWT-60	work table	60"	30"	36"	N/A	N/A	N/A	200	125	\$3,772
PWT-74	work table	74"	30"	36"	N/A	N/A	N/A	230	125	\$3,960

Shelleyglas accessories and modifications can be found on pages 105-114.

**Additional Warranties**

Net Pricing

One year parts and labor contract --- \$279

Two year parts and labor contract -- \$523



# SHELLESTEEL/SHELLEYGLAS EQUIPMENT ACCESSORIES



A. 12" stainless steel V fold-down tray slide

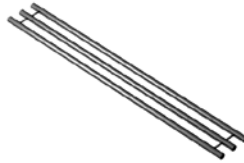

C. 10" three-bar tubular fold-down tray slide



D. 10" composite fold-down cutting board



E. 10" stainless steel fold-down work shelf

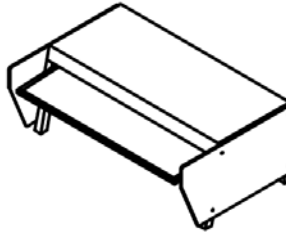

G. Glass front counter protector

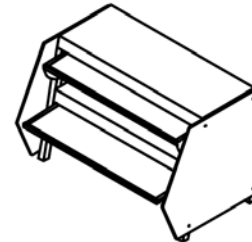

H. Two-tier display w/glass shelves and sneeze guards

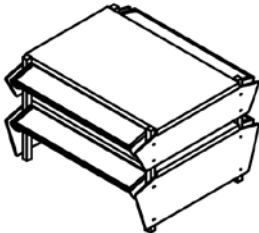

HD. Double service two-tier display with glass shelves and sneeze guards



I. Three-tier display w/glass shelves and sneeze guards

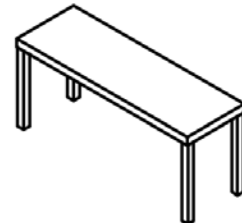

J. 12" stainless steel overshef, 18-gauge

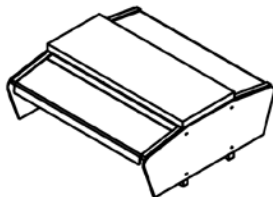

KD. Double service flip-up sneeze guard shown with optional powder coating

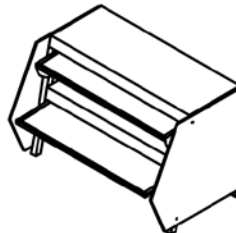

KS. Single service flip-up sneeze guard shown with optional powder coating



P. Open shelf understorage

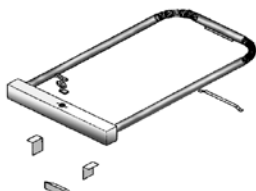

S. Lid locking device

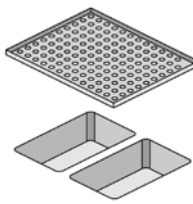

SG16. Pizza pan insert

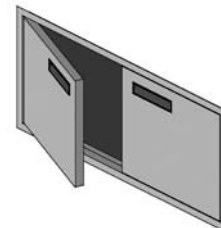

SG9A. Single mechanical access door to interior  
SG9B. Double mechanical access doors to interior - shown

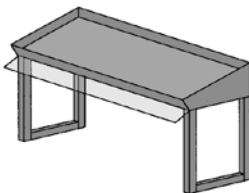

SG22A. Slanted overshef

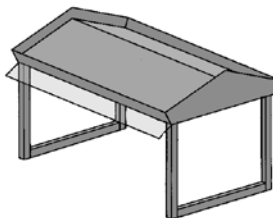

SG22B. Double slanted overshef

**Accessory and modifications pricing on pages 106-114.**

SHELLESTEEL/SHELLEYGLAS SERVING LINE ACCESSORIES

# SHELLEYSTEEL/SHELLEYGLAS EQUIPMENT ACCESSORIES

## KH/SH - HEATED SERVING COUNTERS

	-2	-3	-4	-5	-6
A. 12" stainless steel V fold-down tray slide (old style)	\$1,014	\$1,217	\$1,462	\$1,801	\$2,060
B. 12" stainless steel V style, 14-gauge fold-down tray slide	\$1,014	\$1,217	\$1,462	\$1,801	\$2,060
C. 10" three-bar tubular fold-down tray slide	\$698	\$973	\$1,150	\$1,384	\$1,845
D. 10" composite fold-down cutting board	\$1,026	\$1,141	\$1,435	\$1,660	\$2,240
E. 10" stainless steel fold-down work shelf	\$854	\$1,146	\$1,374	\$1,704	\$2,177
F. Line-up interlock device	N/C	N/C	N/C	N/C	N/C
FD. Fiberglass door panel insert (KH only)	\$427	\$427	\$427	\$427	\$427
G. Glass front counter protector	\$1,586	\$1,823	\$2,177	\$2,622	\$3,003
J. 12" stainless steel overshef, 18-gauge	\$638	\$924	\$1,003	\$1,401	\$1,761
J2. 12" stainless steel overshef — two tier	\$1,276	\$1,849	\$2,010	\$2,801	\$3,528
KD. Double service flip-up sneeze guard	\$1,751	\$1,998	\$2,403	\$2,975	\$3,326
KS. Single service flip-up sneeze guard	\$1,224	\$1,479	\$1,731	\$2,151	\$2,311
L. Incandescent light fixture*	\$695	\$794	\$996	\$1,198	\$1,392
M. Radiant heat lamp w/ on-off switch (fits G, J, KS, KD)*	\$1,344	\$1,498	\$1,719	\$1,999	\$2,706
MB. Bullet-style heat lamp*	\$1,279	\$1,712	\$2,135	\$2,585	\$3,372
P. Open understorage with shelf (KH-NU & SH-NU only)	\$1,493	\$1,782	\$2,009	\$2,240	\$2,696
Q. 115/15A outlet with 10A breaker*	\$848	\$848	\$848	\$848	\$848
QQ. Drains from food wells, plumbed to common valve	\$870	\$1,198	\$1,482	\$1,831	\$2,512
ST. Stainless steel trim strip	\$250	\$250	\$250	\$250	\$250
U. 14" x 30" stainless steel end drop shelf	\$749	\$749	\$749	\$749	\$749
UU. Molded fiberglass trim strip (KH only) each	\$466	\$466	\$466	\$466	\$466
V. Adjustable stainless steel bullet feet	N/C	N/C	N/C	N/C	N/C
Laminate exterior base finish (SH units only)	N/C	N/C	N/C	N/C	N/C
Three phase electrical system	\$958	\$958	\$958	\$958	\$958
Omit <u>one</u> hot food well (credit)	(\$286)				

\* Inclusion of these options will alter the electrical specifications of unit.

## KCSC/SCSC - REFRIGERATED COLD PAN SERVING COUNTERS

	-36	-50	-60	-74	-96
A. 12" stainless steel V fold-down tray slide (old style)	\$1,014	\$1,240	\$1,462	\$1,835	\$2,060
B. 12" stainless steel V style, 14-gauge fold-down tray slide	\$1,014	\$1,217	\$1,462	\$1,801	\$2,060
C. 10" three-bar tubular fold-down tray slide	\$698	\$973	\$1,150	\$1,384	\$1,845
D. 10" composite fold-down cutting board	\$1,026	\$1,141	\$1,435	\$1,660	\$2,240
E. 10" stainless steel fold-down work shelf	\$854	\$1,146	\$1,374	\$1,704	\$2,177
F. Line-up interlock device	N/C	N/C	N/C	N/C	N/C
FD. Fiberglass door panel insert (KCSC only)	\$427	\$427	\$427	\$427	\$427
G. Glass front counter protector	\$1,586	\$1,823	\$2,177	\$2,622	\$3,003
H. Two-tier display w/glass shelves & sneeze guard	\$2,427	\$3,262	\$3,884	\$4,886	\$5,300
HD. Double service two-tier display with sneeze guard	\$3,144	\$3,950	\$4,774	\$5,864	\$6,838
I. Three-tier display w/glass shelves & sneeze guard	\$4,634	\$5,593	\$5,947	\$7,053	\$8,743
J. 12" stainless steel overshef, 18-gauge	\$633	\$916	\$994	\$1,388	\$1,745
J2. 12" stainless steel overshef — two tier	\$1,263	\$1,831	\$1,989	\$2,775	\$3,493
KD. Double service flip-up sneeze guard	\$1,734	\$1,980	\$2,381	\$2,946	\$3,296
KS. Single service flip-up sneeze guard	\$1,213	\$1,479	\$1,731	\$2,151	\$2,289
L. Incandescent light fixture*	\$695	\$794	\$996	\$1,198	\$1,392
PR. Open understorage with shelf	\$1,298	\$1,422	\$1,648	\$1,867	\$2,064
Q. 115/15A outlet with 10A breaker*	\$848	\$848	\$848	\$848	\$848
ST. Stainless steel trim strip	\$250	\$250	\$250	\$250	\$250
U. 14" x 30" stainless steel end drop shelf	\$749	\$749	\$749	\$749	\$749
UU. Molded fiberglass trim strip (KCSC only) each	\$466	\$466	\$466	\$466	\$466
V. Adjustable stainless steel bullet feet	N/C	N/C	N/C	N/C	N/C
Laminate exterior base finish (SCSC units only)	N/C	N/C	N/C	N/C	N/C
Decrease depth of cold pan 1.38" - 5"	N/C	N/C	N/C	N/C	N/C
Increase depth of cold pan 7" - 12"	\$963	\$963	\$963	\$963	\$963

\* Inclusion of these options will alter the electrical specifications of unit.





**KHC, KHCR/SHC & SHCR - HOT & COLD COMBINATION COUNTERS**

	-50	-60	-74	-96
A. 12" stainless steel V fold-down tray slide (old style)-----	\$1,240	\$1,462	\$1,835	\$2,060
B. 12" stainless steel V style, 14-gauge fold-down tray slide-----	\$1,217	\$1,462	\$1,801	\$2,060
C. 10" three-bar tubular fold-down tray slide-----	\$973	\$1,150	\$1,384	\$1,845
D. 10" composite fold-down cutting board-----	\$1,141	\$1,435	\$1,660	\$2,240
E. 10" stainless steel fold-down work shelf-----	\$1,146	\$1,374	\$1,704	\$2,177
F. Line-up interlock device-----	N/C	N/C	N/C	N/C
G. Glass front counter protector-----	\$1,823	\$2,177	\$2,622	\$3,003
H. Two-tier display w/glass shelves & sneeze guard-----	\$3,262	\$3,884	\$4,886	\$5,300
HD. Double service two-tier display with sneeze guard-----	\$3,950	\$4,774	\$5,864	\$6,838
I. Three-tier display w/glass shelves & sneeze guard-----	\$5,593	\$5,947	\$7,053	\$8,743
J. 12" stainless steel overshef, 18-gauge-----	\$916	\$994	\$1,388	\$1,745
J2. 12" stainless steel overshef — two tier-----	\$1,831	\$1,989	\$2,775	\$3,493
KD. Double service flip-up sneeze guard-----	\$1,980	\$2,381	\$2,946	\$3,296
KS. Single service flip-up sneeze guard-----	\$1,479	\$1,731	\$2,151	\$2,289
L. Incandescent light fixture*-----	\$794	\$996	\$1,198	\$1,392
M. Radiant heat lamp w/ on-off switch (fits G, J, KS, KD)*-----	\$1,498	\$1,719	\$1,999	\$2,706
MB. Bullet-style heat lamp*-----	\$1,712	\$2,135	\$2,585	\$3,372
PR. Open understorage with shelf-----	\$1,422	\$1,648	\$1,867	\$2,064
Q. 115/15A outlet with 10A breaker*-----	\$848	\$848	\$848	\$848
QQ. Drains from food wells, plumbed to common valve-----	\$1,198	\$1,482	\$1,831	\$2,512
ST. Stainless steel trim strip-----	\$250	\$250	\$250	\$250
U. 14" x 30" stainless steel end drop shelf-----	\$749	\$749	\$749	\$749
UU. Molded fiberglass trim strip (KCSR only) each-----	\$466	\$466	\$466	\$466
V. Adjustable stainless steel bullet feet-----	N/C	N/C	N/C	N/C
Laminate exterior base finish (SHCR units only)-----	N/C	N/C	N/C	N/C

\* Inclusion of these options will alter the electrical specifications of unit.

**KCFT/SCFT - FROST TOP SERVING COUNTERS**

	-36	-50	-60	-74	-96
A. 12" stainless steel V fold-down tray slide (old style)-----	\$1,014	\$1,240	\$1,462	\$1,835	\$2,060
B. 12" stainless steel V style, 14-gauge fold-down tray slide-----	\$1,014	\$1,217	\$1,462	\$1,801	\$2,060
C. 10" three-bar tubular fold-down tray slide-----	\$698	\$973	\$1,150	\$1,384	\$1,845
D. 10" composite fold-down cutting board-----	\$1,026	\$1,141	\$1,435	\$1,660	\$2,240
E. 10" stainless steel fold-down work shelf-----	\$854	\$1,146	\$1,374	\$1,704	\$2,177
F. Line-up interlock device-----	N/C	N/C	N/C	N/C	N/C
FD. Fiberglass door panel insert (KCFT only)-----	\$427	\$427	\$427	\$427	\$427
G. Glass front counter protector-----	\$1,586	\$1,823	\$2,177	\$2,622	\$3,003
H. Two-tier display w/glass shelves & sneeze guard-----	\$2,427	\$3,262	\$3,884	\$4,886	\$5,300
HD. Double service two-tier display with sneeze guard-----	\$3,144	\$3,950	\$4,774	\$5,864	\$6,838
I. Three-tier display w/glass shelves & sneeze guard-----	\$4,634	\$5,593	\$5,947	\$7,053	\$8,743
J. 12" stainless steel overshef, 18-gauge-----	\$633	\$916	\$994	\$1,388	\$1,745
J2. 12" stainless steel overshef — two tier-----	\$1,263	\$1,831	\$1,989	\$2,775	\$3,493
KD. Double service flip-up sneeze guard-----	\$1,734	\$1,980	\$2,381	\$2,946	\$3,296
KS. Single service flip-up sneeze guard-----	\$1,213	\$1,479	\$1,731	\$2,151	\$2,289
L. Incandescent light fixture*-----	\$695	\$794	\$996	\$1,198	\$1,392
PR. Open understorage with shelf-----	\$1,298	\$1,422	\$1,648	\$1,867	\$2,064
PS. Pan slides (in refrigerated understorage only)-----	\$594	\$594	\$594	\$594	\$594
Q. 115/15A outlet with 10A breaker*-----	\$848	\$848	\$848	\$848	\$848
ST. Stainless steel trim strip-----	\$250	\$250	\$250	\$250	\$250
U. 14" x 30" stainless steel end drop shelf-----	\$749	\$749	\$749	\$749	\$749
UU. Molded fiberglass trim strip (KCFT only) each-----	\$466	\$466	\$466	\$466	\$466
V. Adjustable stainless steel bullet feet-----	N/C	N/C	N/C	N/C	N/C
Laminate exterior base finish (SCFT units only)-----	N/C	N/C	N/C	N/C	N/C

\* Inclusion of these options will alter the electrical specifications of unit.

# SHELLEYSTEEL/SHELLEYGLAS EQUIPMENT ACCESSORIES

## KCI/SCI - ICE PAN SERVING COUNTERS

	-36	-50	-60	-74	-96
A. 12" stainless steel V fold-down tray slide (old style)-----	\$1,014	\$1,240	\$1,462	\$1,835	\$2,060
B. 12" stainless steel V style, 14-gauge fold-down tray slide-----	\$1,014	\$1,217	\$1,462	\$1,801	\$2,060
C. 10" three-bar tubular fold-down tray slide-----	\$698	\$973	\$1,150	\$1,384	\$1,845
D. 10" composite fold-down cutting board-----	\$1,026	\$1,141	\$1,435	\$1,660	\$2,240
E. 10" stainless steel fold-down work shelf-----	\$854	\$1,146	\$1,374	\$1,704	\$2,177
F. Line-up interlock device-----	N/C	N/C	N/C	N/C	N/C
FD. Fiberglass door panel insert (KCI only)-----	\$427	\$427	\$427	\$427	\$427
G. Glass front counter protector-----	\$1,586	\$1,823	\$2,177	\$2,622	\$3,003
H. Two-tier display w/glass shelves & sneeze guard-----	\$2,427	\$3,262	\$3,884	\$4,886	\$5,300
HD. Double service two-tier display with sneeze guard-----	\$3,144	\$3,950	\$4,774	\$5,864	\$6,838
I. Three-tier display w/glass shelves & sneeze guard-----	\$4,634	\$5,593	\$5,947	\$7,053	\$8,743
J. 12" stainless steel overshef, 18-gauge-----	\$633	\$916	\$994	\$1,388	\$1,745
J2. 12" stainless steel overshef — two tier-----	\$1,263	\$1,831	\$1,989	\$2,775	\$3,493
KD. Double service flip-up sneeze guard-----	\$1,734	\$1,980	\$2,381	\$2,946	\$3,296
KS. Single service flip-up sneeze guard-----	\$1,213	\$1,479	\$1,731	\$2,151	\$2,289
L. Incandescent light fixture*-----	\$695	\$794	\$996	\$1,198	\$1,392
P. Open understorage with shelf-----	\$1,493	\$1,782	\$2,009	\$2,240	\$2,696
ST. Stainless steel trim strip-----	\$250	\$250	\$250	\$250	\$250
U. 14" x 30" stainless steel end drop shelf-----	\$749	\$749	\$749	\$749	\$749
UU. Molded fiberglass trim strip-----	\$466	\$466	\$466	\$466	\$466
V. Adjustable stainless steel bullet feet-----	N/C	N/C	N/C	N/C	N/C
Modify depth of cold pan (1.38" to 5")-----	N/C	N/C	N/C	N/C	N/C
Increase depth of cold pan 7" - 12" any length up to 96"-----	\$924	\$924	\$924	\$924	\$924
Laminate exterior base finish (SCI-NU units only)-----	N/C	N/C	N/C	N/C	N/C

\* Inclusion of these options will alter the electrical specifications of unit.

## KCU/SCU - BEVERAGE COUNTERS

	-36	-50	-60	-74	-96
A. 12" stainless steel V fold-down tray slide (old style)-----	\$1,014	\$1,240	\$1,462	\$1,835	\$2,060
B. 12" stainless steel V style, 14-gauge fold-down tray slide-----	\$1,014	\$1,217	\$1,462	\$1,801	\$2,060
C. 10" three-bar tubular fold-down tray slide-----	\$698	\$973	\$1,150	\$1,384	\$1,845
D. 10" composite fold-down cutting board-----	\$1,026	\$1,141	\$1,435	\$1,660	\$2,240
E. 10" stainless steel fold-down work shelf-----	\$854	\$1,146	\$1,374	\$1,704	\$2,177
F. Line-up interlock device-----	N/C	N/C	N/C	N/C	N/C
FD. Fiberglass door panel insert (KCu only)-----	\$427	\$427	\$427	\$427	\$427
FF. Extra drain trough for dual service-----	\$909	\$1,053	\$1,218	\$1,387	\$1,530
P. Open understorage with shelf (KCU-NU & SCU-NU units only)-----	\$1,493	\$1,782	\$2,009	\$2,240	\$2,696
Q. 115/15A outlet with 10A breaker*-----	\$848	\$848	\$848	\$848	\$848
ST. Stainless steel trim strip-----	\$250	\$250	\$250	\$250	\$250
U. 14" x 30" stainless steel end drop shelf-----	\$749	\$749	\$749	\$749	\$749
UU. Molded fiberglass trim strip (KCFT only) each-----	\$466	\$466	\$466	\$466	\$466
V. Adjustable stainless steel bullet feet-----	N/C	N/C	N/C	N/C	N/C
Laminate exterior base finish (SCU units only)-----	N/C	N/C	N/C	N/C	N/C

\* Inclusion of these options will alter the electrical specifications of unit.





# SHELLEYSTEEL/SHELLEYGLAS EQUIPMENT ACCESSORIES

## KC/SC - ALL PURPOSE COUNTERS

	-36	-50	-60	-74	-96
A. 12" stainless steel V fold-down tray slide (old style)-----	\$1,014	\$1,240	\$1,462	\$1,835	\$2,060
B. 12" stainless steel V style, 14-gauge fold-down tray slide-----	\$1,014	\$1,217	\$1,462	\$1,801	\$2,060
C. 10" three-bar tubular fold-down tray slide-----	\$698	\$973	\$1,150	\$1,384	\$1,845
D. 10" composite fold-down cutting board-----	\$1,026	\$1,141	\$1,435	\$1,660	\$2,240
E. 10" stainless steel fold-down work shelf-----	\$854	\$1,146	\$1,374	\$1,704	\$2,177
F. Line-up interlock device-----	N/C	N/C	N/C	N/C	N/C
FD. Fiberglass door panel insert (KC only)-----	\$427	\$427	\$427	\$427	\$427
G. Glass front counter protector-----	\$1,586	\$1,823	\$2,177	\$2,622	\$3,003
H. Two-tier display w/glass shelves & sneeze guard-----	\$2,427	\$3,262	\$3,884	\$4,886	\$5,300
HD. Double service two-tier display with sneeze guard-----	\$3,144	\$3,950	\$4,774	\$5,864	\$6,838
I. Three-tier display w/glass shelves & sneeze guard-----	\$4,634	\$5,593	\$5,947	\$7,053	\$8,743
J. 12" stainless steel overshef, 18-gauge-----	\$633	\$916	\$994	\$1,388	\$1,745
J2. 12" stainless steel overshef — two tier-----	\$1,263	\$1,831	\$1,989	\$2,775	\$3,493
KD. Double service flip-up sneeze guard-----	\$1,734	\$1,980	\$2,381	\$2,946	\$3,296
KS. Single service flip-up sneeze guard-----	\$1,213	\$1,479	\$1,731	\$2,151	\$2,289
L. Incandescent light fixture*-----	\$695	\$794	\$996	\$1,198	\$1,392
M. Radiant heat lamp w/ on-off switch (fits G, J, KS, KD)*-----	\$1,344	\$1,498	\$1,719	\$1,999	\$2,706
MB. Bullet-style heat lamp*-----	\$1,279	\$1,712	\$2,135	\$2,585	\$3,372
P. Open understorage with shelf (KC & SC units only)-----	\$1,493	\$1,782	\$2,009	\$2,240	\$2,696
Q. 115/15A outlet with 10A breaker*-----	\$848	\$848	\$848	\$848	\$848
ST. Stainless steel trim strip-----	\$250	\$250	\$250	\$250	\$250
U. 14" x 30" stainless steel end drop shelf-----	\$749	\$749	\$749	\$749	\$749
UU. Molded fiberglass trim strip (KC only) each-----	\$466	\$466	\$466	\$466	\$466
V. Adjustable stainless steel bullet feet-----	N/C	N/C	N/C	N/C	N/C
Laminate exterior base finish (SC units only)-----	N/C	N/C	N/C	N/C	N/C

\*Inclusion of these options will alter the electrical specifications of unit.

## KCM, KCF, KCFM/SCM, SCF & SCFM - MILK & ICE CREAM COUNTERS

	-36	-50	-60	-74
A. 12" stainless steel V fold-down tray slide (old style)-----	\$1,014	\$1,240	\$1,462	\$1,835
B. 12" stainless steel V style, 14-gauge fold-down tray slide-----	\$1,014	\$1,217	\$1,462	\$1,801
C. 10" three-bar tubular fold-down tray slide-----	\$698	\$973	\$1,150	\$1,384
D. 10" composite fold-down cutting board-----	\$1,026	\$1,141	\$1,435	\$1,660
E. 10" stainless steel fold-down work shelf-----	\$854	\$1,146	\$1,374	\$1,704
F. Line-up interlock device-----	N/C	N/C	N/C	N/C
R. 4" high chrome-plated wire baskets (per three)				
6 baskets (KCF-36 & SCF-36 only)-----	\$920	—	—	—
12 baskets (KCM-50, KCFM-50, SCM-50 & SCFM-50 only)-----	—	\$1,224	—	—
12 baskets (KCF-50 & SCF-50 only)-----	—	\$1,224	—	—
18 baskets (KCFM-60 & SCFM-60 only)-----	—	—	\$1,831	—
24 baskets (KCM-74, KCFM-74, SCM-74 & SCFM-74)-----	—	—	—	\$2,437
S. Lid locking device, with "T" handle-----	\$557	\$557	\$557	\$557
ST. Stainless steel trim strip-----	\$250	\$250	\$250	\$250
U. 14" x 30" stainless steel end drop shelf-----	\$749	\$749	\$749	\$749
UU. Molded fiberglass trim strip (KC only) each-----	\$466	\$466	\$466	\$466
V. Adjustable stainless steel bullet feet-----	N/C	N/C	N/C	N/C
Laminate exterior base finish (SCM, SCF & SCFM units only)-----	N/C	N/C	N/C	N/C
Additional stainless steel divider tray (each)-----	\$30	\$30	\$30	\$30

# SHELLEYSTEEL/SHELLEYGLAS EQUIPMENT ACCESSORIES

## PWT/SWT - SERVING COUNTERS

	-36	-50	-60	-74
D. 10" composite fold-down cutting board	\$1,026	\$1,141	\$1,435	\$1,660
E. 10" stainless steel fold-down work shelf	\$854	\$1,146	\$1,374	\$1,704
EE. Stainless steel locking utility drawer	\$973	\$973	\$973	\$973
F. Line-up interlock device	N/C	N/C	N/C	N/C
J. 12" stainless steel overshef, 18-gauge	\$633	\$916	\$994	\$1,388
O. Stainless steel undershef, 16-gauge	\$677	\$820	\$1,133	\$1,363
ST. Stainless steel trim strip	\$250	\$250	\$250	\$250
SW6. (6) Silverware cutouts w/plastic bins	\$814	\$814	\$814	\$814
SW8. (8) Silverware cutouts w/plastic bins	\$973	\$973	\$973	\$973
SW10. (10) Silverware cutouts w/plastic bins	\$1,133	\$1,133	\$1,133	\$1,133
U. 14" x 30" stainless steel end drop shelf	\$749	\$749	\$749	\$749
UU. Molded fiberglass trim strip each	\$466	\$466	\$466	\$466
V. Adjustable stainless steel bullet feet	N/C	N/C	N/C	N/C

## KCS/SCS, KRB/SRB & KCTS/SCTS - UTILITY EQUIPMENT

A. 12" stainless steel V fold-down tray slide	\$971
B. 12" stainless steel V style, 14-gauge fold-down tray slide	\$1,014
C. 10" three-bar tubular fold-down tray slide	\$664
D. 10" composite fold-down cutting board	\$974
E. 10" stainless steel fold-down work shelf	\$881
F. Line-up interlock device	N/C
FD. Fiberglass door panel insert (KRB only)	\$427
PAN3. (3) 1/3 x 6" deep pans	\$809
Q. 115/15A outlet with 10A breaker*	\$807
ST. Stainless steel trim strip	\$236
SW6. (6) Silverware cutouts w/plastic bins	\$814
SW8. (8) Silverware cutouts w/plastic bins	\$974
SW8-PI. (8) Silverware cutouts w/ plastic bins and (1) 1/3 x 6" deep pan	\$1,290
SW10. (10) Silverware cutouts w/stainless steel bins	\$1,133
T. Heated storage with stainless steel center wire shelf (KRB/SRB only)	\$2,027
U. 14" x 30" stainless steel end drop shelf	\$691
UU. Molded fiberglass trim strip each	\$443
V. Adjustable stainless steel bullet feet	N/C

\* Inclusion of these options will alter the electrical specifications of unit.

# SHELLEYSTEEL/SHELLEYGLAS EQUIPMENT ACCESSORIES

## Special Modifications (available on all equipment except where noted)

<b>SG1</b>	<b>Backsplash</b>						
	A. 2" x 4" backsplash return on end -----					\$498	
	B. 2" x 4" high backsplash (per foot; 3' minimum) -----					\$543	
<b>SG2</b>	<b>Custom Fiberglass Color</b> ( <i>Shelleyglas only</i> ) sample required						
	Add to standard unit price; specify color on original order (per job) -----					\$1,227	
<b>SG2PS</b>	<b>Custom Polystone Fiberglass Color</b> ( <i>Shelleyglas only</i> )						
	Add to standard unit price; specify color on original order (per unit) -----					\$645	
<b>SG3</b>	<b>Deck Mounted Outlets</b> -----					\$1,130	
<b>SG5</b>	<b>Dry Storage Compartments</b>						
	A. Single door -----					\$2,129	
	B. Double door -----					\$2,897	
<b>SG6</b>	<b>Fan Assist Package</b> (Refrigerated cold pans) -----					\$987	
<b>SG7</b>	<b>Ferruled Holes</b>						
	B. 1" diameter (each) -----					\$83	
	C. 2" diameter (each) -----					\$83	
<b>SG8</b>	<b>Heated Interior Sections</b>						
	A. Single door with pan slides 15.62" long -----					\$2,499	
	B. Single door with pan slides 28.62" long -----					\$4,724	
<b>SG9</b>	<b>Mechanical Access Doors to Interior</b>						
	A. Single door -----					\$1,264	
	B. Double door -----					\$1,702	
	C. Single louver door -----					\$1,498	
<b>SG10</b>	<b>Highlight Finish</b> top edge of unit each unit						
	A. 36" minimum -----					\$911	
	B. Each additional inch over 36" -----					\$30	
<b>SG11</b>	<b>Modify Standard Height</b> Modify height of unit to height 28", 30", 32", 34" & 36" (only) -----					NO CHARGE	
<b>SG12</b>	<b>Modify Standard Length</b> ( <i>Shelleyglas only</i> )						
	Add pricing off chart on next page to standard base pricing.						
	Price includes a top extension -----					SEE CHART ON NEXT PAGE	
<b>SG14</b>	<b>Modify Standard Top Depth</b>						
		-28	-36	-50	-60	-74	-96
	A. 1" to 6"	\$446	\$446	\$446	\$736	\$885	\$1,187
	B. 7" to 12"	\$744	\$744	\$1,004	\$1,252	\$1,502	\$1,999
<b>SG15</b>	<b>Paper Cup Dispenser</b> Specify cup manufacturer and rim diameter -----						\$706
<b>SG16</b>	<b>Pizza Pan Insert</b> -----						\$587
<b>SG17</b>	<b>Powder Coating</b> -----						CONTACT FACTORY
	A. G Style counter protector -----						per inch \$17
	B. H Style counter protector -----						per inch \$27
	C. HD Style counter protector -----						per inch \$36
	D. I Style counter protector -----						per inch \$48
	E. KD Style sneeze guard -----						per inch \$19
	F. KS Style sneeze guard -----						per inch \$13
	G. Shelley canopy -----						per inch \$26

# SHELLEYSTEEL/SHELLEYGLAS EQUIPMENT ACCESSORIES

## SG12 Standard length modification chart (for Shelleyglas only)

MODEL NUMBERS	OVERALL LENGTH	LIST PRICE	MODEL NUMBERS	OVERALL LENGTH	LIST PRICE	MODEL NUMBERS	OVERALL LENGTH	LIST PRICE
<b>STANDARD 28"</b>			SG12-60-6	65	\$2,445	SG12-96-7	103	\$3,492
SG12-28-1	29	\$2,076	SG12-60-7	66	\$2,478	SG12-96-8	104	\$3,526
SG12-28-2	30	\$2,109	SG12-60-8	67	\$2,514	SG12-96-9	105	\$3,557
SG12-28-3	31	\$2,142	SG12-60-9	68	\$2,546	SG12-96-10	106	\$3,593
SG12-28-4	32	\$2,177	SG12-60-10	69	\$2,582	SG12-96-11	107	\$3,627
SG12-28-5	33	\$2,211	SG12-60-11	70	\$2,613	SG12-96-12	108	\$3,661
SG12-28-6	34	\$2,246	SG12-60-12	71	\$2,649	SG12-96-13	109	\$3,680
SG12-28-7	35	\$2,280	SG12-60-13	72	\$2,667	SG12-96-14	110	\$3,695
<b>STANDARD 36"</b>			<b>STANDARD 74"</b>			SG12-96-15	111	\$3,711
SG12-36-1	37	\$2,153	SG12-74-1	75	\$2,703	SG12-96-16	112	\$3,729
SG12-36-2	38	\$2,188	SG12-74-2	76	\$2,737	SG12-96-17	113	\$3,744
SG12-36-3	39	\$2,220	SG12-74-3	77	\$2,771	SG12-96-18	114	\$3,762
SG12-36-4	40	\$2,253	SG12-74-4	78	\$2,802	SG12-96-19	115	\$3,780
SG12-36-5	41	\$2,288	SG12-74-5	79	\$2,839	SG12-96-20	116	\$3,797
SG12-36-6	42	\$2,323	SG12-74-6	80	\$2,873	SG12-96-21	117	\$3,815
SG12-36-7	43	\$2,356	SG12-74-7	81	\$2,905	SG12-96-22	118	\$3,830
SG12-36-8	44	\$2,390	SG12-74-8	82	\$2,940	SG12-96-23	119	\$3,848
SG12-36-9	45	\$2,422	SG12-74-9	83	\$2,974	SG12-96-24	120	\$3,863
SG12-36-10	46	\$2,457	SG12-74-10	84	\$3,008	SG12-96-125	121	\$3,879
SG12-36-11	47	\$2,493	SG12-74-11	85	\$3,042	SG12-96-26	122	\$3,899
SG12-36-12	48	\$2,525	SG12-74-12	86	\$3,075	SG12-96-27	123	\$3,914
SG12-36-13	49	\$2,541	SG12-74-13	87	\$3,094	SG12-96-28	124	\$3,932
<b>STANDARD 50"</b>			SG12-74-14	88	\$3,108	SG12-96-29	125	\$3,950
SG12-50-1	51	\$2,203	SG12-74-15	89	\$3,125	SG12-96-30	126	\$3,965
SG12-50-2	52	\$2,237	SG12-74-16	90	\$3,144	SG12-96-31	127	\$3,984
SG12-50-3	53	\$2,271	SG12-74-17	91	\$3,159	SG12-96-32	128	\$4,001
SG12-50-4	54	\$2,305	SG12-74-18	92	\$3,177	SG12-96-33	129	\$4,016
SG12-50-5	55	\$2,339	SG12-74-19	93	\$3,194	SG12-96-34	130	\$4,033
SG12-50-6	56	\$2,371	SG12-74-20	94	\$3,211	SG12-96-35	131	\$4,050
SG12-50-7	57	\$2,407	SG12-74-21	95	\$3,228	SG12-96-36	132	\$4,068
SG12-50-8	58	\$2,440	<b>STANDARD 96"</b>			SG12-96-37	133	\$4,085
SG12-50-9	59	\$2,475	SG12-96-1	97	\$3,288	SG12-96-38	134	\$4,101
<b>STANDARD 60"</b>			SG12-96-2	98	\$3,322	SG12-96-39	135	\$4,119
SG12-60-1	61	\$2,276	SG12-96-3	99	\$3,357	SG12-96-40	136	\$4,135
SG12-60-2	62	\$2,309	SG12-96-4	100	\$3,389	SG12-96-41	137	\$4,154
SG12-60-3	63	\$2,343	SG12-96-5	101	\$3,423			
SG12-60-4	64	\$2,377	SG12-96-6	102	\$3,458			
SG12-60-5	65	\$2,412						



## Special Modifications (available on all equipment except where noted)

<b>SG18</b>	<b>Push/Pull Handles</b> Stainless steel -----	<b>\$477</b>
<b>SG19</b>	<b>Heated Tops</b>	
	A. 17.12" x 25.12" recessed 1" -----	<b>\$2,323</b>
	B. 20.12" x 26.26" recessed 1" -----	<b>\$2,575</b>
	C. 25.12" x 35.25" recessed 1" -----	<b>\$4,644</b>
	D. 17.12" x 25.12" flat heated -----	<b>\$2,323</b>
	E. 20.12" x 26.26" flat heated -----	<b>\$2,575</b>
	F. 25.12" x 35.25" flat heated -----	<b>\$4,644</b>
<b>SG20</b>	<b>Refrigerated Understorage Only</b> fits in 60" or longer units, single door	
	A. With 1/4 h.p. condensing unit -----	<b>\$7,324</b>
	B. Without condensing unit when added to self-contained KCSC or SCSC models-----	<b>\$5,153</b>
<b>SG21</b>	<b>A. Soup Wells</b> 10.5" diameter, with control panel -----	<b>\$1,558</b>
	<b>B. Soup Wells</b> 8.5" diameter, with control panel -----	<b>\$1,412</b>
<b>SG22</b>	<b>Slanted Overshelves</b>	
	A. Single (per foot; 3' minimum) -----	<b>\$1,104</b>
	B. Double (per foot; 3' minimum) -----	<b>\$2,724</b>
<b>SG23</b>	<b>Toe Plates</b> Stainless steel (3' minimum) -----	<i>Per linear foot or fraction</i> <b>\$118</b>
<b>SG24</b>	<b>Tray Slides</b> 12" wide laminated fold-down style (per foot; add to tray slide price)-----	<b>\$408</b>
<b>SG25</b>	<b>Canopy and accessories</b>	
	A. Dome style -----	<i>Per inch</i> <b>\$57</b>
	B. Peak style -----	<i>Per inch</i> <b>\$83</b>
	C. Bus style -----	<i>Per inch</i> <b>\$43</b>
	D. Stationary frame-----	<b>\$1,456</b>
	E. Adjustable (tube in tube) frame-----	<b>\$2,733</b>
	F. 3" letters -----	<i>Each</i> <b>\$34</b>
	G. 2" or 3" stripe on canopy -----	<i>Per inch</i> <b>\$34</b>
<b>SG26</b>	<b>Bus theme</b> , includes, wheels, lights, windshield wipers, striping, license plate, fenders and doors only (does not include canopy, trim strips, lettering or over structure).	
	A. Single side only -----	<b>\$5,692</b>
	B. Dual sided bus -----	<b>\$7,417</b>
<b>SG27</b>	<b>Boat theme</b> , includes smoke stack with smoke, bow piece, flag, anchor, bell, and name plate (does not include waves, trim stripes or portholes).	
	A. Basic package single/dual -----	<b>\$7,541</b>
	B. Portholes-----	<i>Each</i> <b>\$189</b>
	C. Wave kick plates -----	<i>Per inch</i> <b>\$33</b>
<b>SG28</b>	<b>Train/Circus Train theme</b> , includes smoke stack, engine wheels with piston, cow catcher, cab over shelf, bell, and headlight (does not include wheels for following cars, circus animals, canopy, lettering).	
	A. Single side only -----	<b>\$10,263</b>
	B. Dual side train engine-----	<b>\$12,030</b>
	C. Circus animals-----	<i>Each</i> <b>\$593</b>
	D. Balloons, set of three in cluster -----	<b>\$206</b>
	E. Set of two wheels per side for following cars-----	<b>\$279</b>

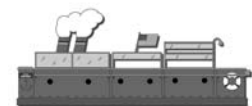

# SHELLEYSSTEEL/SHELLEYGLAS EQUIPMENT ACCESSORIES

## Special Modifications (available on all equipment except where noted)

- SG29 Rocket theme**, includes nose cone, graphics, and tail wing (does not include trim strips).
- A. Single side only ----- **\$7,676**
  - B. Dual sided rocket ----- **\$9,314**

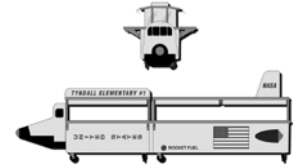

- SG30 Standoff Decor Panel**, 18"x18" Shelleyglas/Shelleysteel ----- **Consult Factory**

- SG31 Standoff Decor Panel**, Flexible size Shelleyglas/Shelleysteel/Concepts ----- **Consult Factory**

## TE

**Top extensions** (added to base as flat top area)

TE option should only be used for standard length units. Please contact the factory for custom length pricing.

- TE8.** 8" extension ----- **\$295**
- TE10.** 10" extension ----- **\$510**
- TE14.** 14" extension ----- **\$782**
- TE22.** 22" extension ----- **\$1,077**
- TE24.** 24" extension ----- **\$1,387**
- TE32.** 32" extension ----- **\$1,985**
- TE36.** 36" extension ----- **\$1,985**
- TE38.** 38" extension ----- **\$2,118**

## Spacer Options

The spacer option (wainscot) includes top, interlocks and legs.

Please specify fiberglass, stainless steel or laminate when ordering.

- KSPC.** Fiberglass spacer ----- per linear inch **\$39**
- SSPC.** Stainless steel spacer ----- per linear inch **\$32**
- LSPC.** Laminate spacer ----- per linear inch **\$35**

## Power Pole Options

**PP21-30.** 120/208 volt, 3-phase, 30 amp pole ----- per pole **\$534**

**PP14-50.** Locking 120/208 volt, single-phase, 50 amp pole ----- per pole **\$1,052**

# SPH SERIES - MOBILE HEATED SPEED LINE MODULES



SPH-50

## Product Information

- 14-gauge stainless steel top standard
- 9' long cord and plug are supplied standard
- 18-gauge stainless steel exterior standard
- Electrical: 120 volt, 60 cycle, single phase
- Removable sliding lids (two per unit) standard
- Standard on 5" diameter polyurethane swivel casters
- Stainless steel fully retractable interlock provided as standard
- Basket rack system is standard
- A wide selection of laminate colors available at no additional charge
- Laminate selection has 18-gauge galvanized base, 16-gauge coved corner supports to protect laminate
- Stay cool surface: Top is designed to stay below 90°, making it safe to touch
- Fin style element maintains even heating temperatures throughout the interior of the cabinet
- Meets NSF2, NSF4, UL and CEC standards
- One year parts and 90 day labor standard warranty. Additional warranties available, see below

## Specifications and Prices

MODEL NUMBER	DESCRIPTION	OVERALL			BASKET CAPACITY	STORAGE CAPACITY (CU. FT.)	AMP	VOLTS	WATTS	NEMA PLUG	SHIP WEIGHT	FREIGHT CLASS	LIST PRICE
		L	D	H									
<b>SHELLEYSPEED™ HEATED MODULE</b>													
SPH-40	heated module	40"	30"	34"	12(13.25"x20.5"x2.5") 6(13.25"x20.5"x4.75")	4.73	17.0	120	1800	5-30P	370	100	\$8,638
SPH-50	heated module	50"	30"	34"	18(13.25"x20.5"x2.5") 9(13.25"x20.5"x4.75")	7.06	17.0	120	1800	5-30P	525	100	\$9,299
SPH-64	heated module	64"	30"	34"	24(13.25"x20.5"x2.5") 12(13.25"x20.5"x4.75")	9.33	17.0	120	1800	5-30P	550	100	\$13,234
<b>SHELLEYSPEED™ HEATED MODULE - ELEMENTARY HEIGHT</b>													
SPH-40E	heated module	40"	30"	30"	8(13.25"x20.5"x2.5") 4(13.25"x20.5"x4.75")	3.37	17.0	120	1800	5-30P	370	100	\$8,638
SPH-50E	heated module	50"	30"	30"	12(13.25"x20.5"x2.5") 6(13.25"x20.5"x4.75")	5.03	17.0	120	1800	5-30P	525	100	\$9,299
SPH-64E	heated module	64"	30"	30"	16(13.25"x20.5"x2.5") 8(13.25"x20.5"x4.75")	6.69	17.0	120	1800	5-30P	550	100	\$13,234
<b>SHELLEYSPEED™ HEATED MODULE - WIDE WIDTH</b>													
SPH-40W	heated module	40"	35"	34"	12(13.25"x26.13"x2.5") 6(13.25"x26.13"x4.75")	5.82	17.0	120	1800	5-30P	370	100	\$8,799
SPH-50W	heated module	50"	35"	34"	18(13.25"x26.13"x2.5") 9(13.25"x26.13"x4.75")	8.68	17.0	120	1800	5-30P	525	100	\$9,448
SPH-64W	heated module	64"	35"	34"	24(13.25"x26.13"x2.5") 12(13.25"x26.13"x4.75")	11.54	17.0	120	1800	5-30P	550	100	\$13,388
<b>SHELLEYSPEED™ HEATED MODULE - WIDE WIDTH, ELEMENTARY HEIGHT</b>													
SPH-40EW	heated module	40"	35"	30"	8(13.25"x26.13"x2.5") 4(13.25"x26.13"x4.75")	4.15	17.0	120	1800	5-30P	370	100	\$8,799
SPH-50EW	heated module	50"	35"	30"	12(13.25"x26.13"x2.5") 6(13.25"x26.13"x4.75")	6.19	17.0	120	1800	5-30P	525	100	\$9,493
SPH-64EW	heated module	64"	35"	30"	16(13.25"x26.13"x2.5") 8(13.25"x26.13"x4.75")	8.22	17.0	120	1800	5-30P	550	100	\$13,388

Shelleyspeed accessories and modifications can be found on page 125-128.

Additional Warranties	
	Net Pricing
One year parts and labor contract -----	\$279
Two year parts and labor contract -----	\$523



# SPR SERIES - MOBILE REFRIGERATED SPEED LINE MODULES



**SPR-50**

Shown with optional merchandising module

## Product Information

- 14-gauge stainless steel top standard
- 9' long cord and plug are supplied standard
- 18-gauge stainless steel exterior standard
- Electrical: 120 volt, 60 cycle, single phase
- R134A refrigerant
- Removable sliding lids (two per unit) standard
- Standard on 5" diameter polyurethane swivel casters
- Stainless steel fully retractable interlock provided as standard
- Forced air cooling system
- Maintains 33° to 41° temperature requirements
- Basket rack system is standard
- A wide selection of laminate colors available at no additional charge
- Laminate selection has 18-gauge galvanized base, 16-gauge coved corner supports to protect laminate
- Meets NSF2, NSF7, UL and CEC standards
- One year parts and 90 day labor standard warranty. Additional warranties available, see below

## Specifications and Prices

MODEL NUMBER	DESCRIPTION	OVERALL			BASKET CAPACITY	STORAGE CAPACITY (CU. FT.)	AMP	HP	VOLTS	NEMA PLUG	SHIP WEIGHT	FREIGHT CLASS	LIST PRICE
		L	D	H									
<b>SHELLEYSPEED™ REFRIGERATED MODULE</b>													
SPR-40	refrigerated module	40"	30"	34"	12(13.25"x20.5"x2.5") 6(13.25"x20.5"x4.75")	4.73	5.0	1/5	120	5-15P	370	100	<b>\$13,424</b>
SPR-50	refrigerated module	50"	30"	34"	18(13.25"x20.5"x2.5") 9(13.25"x20.5"x4.75")	7.06	7.0	1/4	120	5-15P	525	100	<b>\$14,190</b>
SPR-64	refrigerated module	64"	30"	34"	24(13.25"x20.5"x2.5") 12(13.25"x20.5"x4.75")	9.38	7.0	1/4	120	5-15P	550	100	<b>\$14,441</b>
<b>SHELLEYSPEED™ REFRIGERATED MODULE - ELEMENTARY HEIGHT</b>													
SPR-40E	refrigerated module	40"	30"	30"	8(13.25"x20.5"x2.5") 4(13.25"x20.5"x4.75")	3.37	5.0	1/5	120	5-15P	370	100	<b>\$13,424</b>
SPR-50E	refrigerated module	50"	30"	30"	12(13.25"x20.5"x2.5") 6(13.25"x20.5"x4.75")	5.03	7.0	1/4	120	5-15P	525	100	<b>\$14,190</b>
SPR-64E	refrigerated module	64"	30"	30"	16(13.25"x20.5"x2.5") 8(13.25"x20.5"x4.75")	6.69	7.0	1/4	120	5-15P	550	100	<b>\$14,441</b>
<b>SHELLEYSPEED™ REFRIGERATED MODULE - WIDE WIDTH</b>													
SPR-40W	refrigerated module	40"	35"	34"	12(13.25"x26.13"x2.5") 6(13.25"x26.13"x4.75")	5.82	5.0	1/5	120	5-15P	370	100	<b>\$13,667</b>
SPR-50W	refrigerated module	50"	35"	34"	18(13.25"x26.13"x2.5") 9(13.25"x26.13"x4.75")	8.68	7.0	1/4	120	5-15P	525	100	<b>\$14,235</b>
SPR-64W	refrigerated module	64"	35"	34"	24(13.25"x26.13"x2.5") 12(13.25"x26.13"x4.75")	11.54	7.0	1/4	120	5-15P	550	100	<b>\$14,585</b>
<b>SHELLEYSPEED™ REFRIGERATED MODULE - WIDE WIDTH, ELEMENTARY HEIGHT</b>													
SPR-40EW	refrigerated module	40"	35"	30"	8(13.25"x26.13"x2.5") 4(13.25"x26.13"x4.75")	4.15	5.0	1/5	120	5-15P	370	100	<b>\$13,667</b>
SPR-50EW	refrigerated module	50"	35"	30"	12(13.25"x26.13"x2.5") 6(13.25"x26.13"x4.75")	6.19	7.0	1/4	120	5-15P	525	100	<b>\$14,235</b>
SPR-64EW	refrigerated module	64"	35"	30"	16(13.25"x26.13"x2.5") 8(13.25"x26.13"x4.75")	8.22	7.0	1/4	120	5-15P	550	100	<b>\$14,585</b>

Shelleyspeed accessories and modifications can be found on page 125-128.

Additional Warranties	
	Net Pricing
One year parts and labor contract-----	\$279
Two year parts and labor contract-----	\$523
Five year compressor warranty	
1/4 HP -----	\$108
1/5 HP -----	\$108



Effective August 2011. All prices F.O.B. Mt. Pleasant, MI 48858. Prices may vary on accessories ordered from the Parts Department. Visit [www.delfield.com](http://www.delfield.com) for specification sheets.



# SPRH SERIES - MOBILE REFRIGERATOR/HEATED SPEED LINE COMBINATION MODULES



## Product Information

- 14-gauge stainless steel top standard
- 9' long cord and plug are supplied standard
- Two separate systems, one heated, one refrigerated
- 18-gauge stainless steel exterior standard
- Electrical: 120 volt, 60 cycle, single phase
- R134A refrigerant
- Removable sliding lids (two per unit) standard
- Standard on 5" diameter polyurethane swivel casters
- Stainless steel fully retractable interlock provided as standard
- Basket rack system is standard
- A wide selection of laminate colors available at no additional charge
- Heated portion has stay cool surface, top is designed to stay below 90°
- Laminate selection has 18-gauge galvanized base, 16-gauge coved corner supports to protect laminate
- Meets NSF2, NSF4, NSF7, UL and CEC standards
- One year parts and 90 day labor standard warranty. Additional warranties available, see below



SPRH-68

## Specifications and Prices

MODEL NUMBER	DESCRIPTION	OVERALL L	D	H	BASKET CAPACITY	STORAGE CAPACITY (CU. FT.)	AMP	HP	VOLTS	WATTS	NEMA PLUG	SHIP WEIGHT	FREIGHT CLASS	LIST PRICE
<b>SHELLEYSPEED™ REFRIGERATOR/HEATED COMBINATION MODULE</b>														
SPRH-68	refrigerator/ heated combo module	68"	30"	R	12(13.25"x20.5"x2.5") 6(13.25"x20.5"x4.75")	4.73	18.5	1/5	120	N/A	5-30P	410	100	\$26,146
				H	12(13.25"x20.5"x2.5") 6(13.25"x20.5"x4.75")	4.73		N/A	120	1800				
<b>SHELLEYSPEED™ REFRIGERATOR/HEATED COMBINATION MODULE - ELEMENTARY HEIGHT</b>														
SPRH-68E	refrigerator/ heated combo module	68"	30"	R	8(13.25"x20.5"x2.5") 4(13.25"x20.5"x4.75")	3.37	18.5	1/5	120	N/A	5-30P	410	100	\$26,146
				H	8(13.25"x20.5"x2.5") 4(13.25"x20.5"x4.75")	3.37		N/A	120	1800				
<b>SHELLEYSPEED™ REFRIGERATOR/HEATED COMBINATION MODULE - WIDE WIDTH</b>														
SPRH-68W	refrigerator/ heated combo module	68"	35"	R	12(13.25"x26.13"x2.5") 6(13.25"x26.13"x4.75")	5.82	18.5	1/5	120	N/A	5-30P	450	100	\$26,410
				H	12(13.25"x26.13"x2.5") 6(13.25"x26.13"x4.75")	5.82		N/A	120	1800				
<b>SHELLEYSPEED™ REFRIGERATOR/HEATED COMBINATION MODULE - WIDE WIDTH, ELEMENTARY HEIGHT</b>														
SPRH-68EW	refrigerator/ heated combo module	68"	35"	R	8(13.25"x26.13"x2.5") 4(13.25"x26.13"x4.75")	4.15	18.5	1/5	120	N/A	5-30P	450	100	\$26,410
				H	8(13.25"x26.13"x2.5") 4(13.25"x26.13"x4.75")	4.15		N/A	120	1800				

Shelleyspeed accessories and modifications can be found on page 125-128.

### Additional Warranties

	Net Pricing
One year parts and labor contract-----	\$279
Two year parts and labor contract-----	\$523
Five year compressor warranty 1/5 HP -----	\$108

# SPRF SERIES - MOBILE REFRIGERATOR/FREEZER SPEED LINE COMBINATION MODULES



## Product Information



**SPRF-68**

- 14-gauge stainless steel top standard
- Two separate systems, one section refrigerator and one section freezer
- 9' long cord and plug are supplied standard
- 18-gauge stainless steel exterior standard
- Electrical: 120 volt, 60 cycle, single phase
- R134A refrigerant-refrigerator, R404A-freezer
- Removable sliding lids (two per unit) standard
- Standard on 5" diameter polyurethane swivel casters
- Stainless steel fully retractable interlock provided as standard
- Basket rack system is standard
- A wide selection of laminate colors available at no additional charge
- Laminate selection has 18-gauge galvanized base, 16-gauge coved corner supports to protect laminate
- Meets NSF2, NSF7, UL and CEC standards
- One year parts and 90 day labor standard warranty. Additional warranties available, see below

## Specifications and Prices

MODEL NUMBER	DESCRIPTION	L	D	H	BASKET CAPACITY	STORAGE CAPACITY (CU. FT.)	AMP	HP	VOLTS	NEMA PLUG	SHIP WEIGHT	FREIGHT CLASS	LIST PRICE
<b>SHELLEYSPEED™ REFRIGERATOR/FREEZER COMBINATION MODULE</b>													
SPRF-68	refrigerator/ freezer combo module	68"	30"	34"	R	12(13.25"x20.5"x2.5") 6(13.25"x20.5"x4.75")	15.0	1/5	120	5-20P	410	100	\$23,179
					F	12(13.25"x20.5"x2.5") 6(13.25"x20.5"x4.75")							
<b>SHELLEYSPEED™ REFRIGERATOR/FREEZER COMBINATION MODULE - ELEMENTARY HEIGHT</b>													
SPRF-68E	refrigerator/ freezer combo module	68"	30"	30"	R	8(13.25"x20.5"x2.5") 4(13.25"x20.5"x4.75")	15.0	1/5	120	5-20P	410	100	\$23,179
					F	8(13.25"x20.5"x2.5") 4(13.25"x20.5"x4.75")							
<b>SHELLEYSPEED™ REFRIGERATOR/FREEZER COMBINATION MODULE - WIDE WIDTH</b>													
SPRF-68W	refrigerator/ freezer combo module	68"	35"	34"	R	24(13.25"x26.13"x2.5") 12(13.25"x26.13"x4.75")	15.0	1/5	120	5-20P	450	100	\$24,029
					F	24(13.25"x26.13"x2.5") 12(13.25"x26.13"x4.75")							
<b>SHELLEYSPEED™ REFRIGERATOR/FREEZER COMBINATION MODULE - WIDE WIDTH, ELEMENTARY HEIGHT</b>													
SPRF-68EW	refrigerator/ freezer combo module	68"	35"	30"	R	8(13.25"x26.13"x2.5") 4(13.25"x26.13"x4.75")	15.0	1/5	120	5-20P	450	100	\$24,029
					F	8(13.25"x26.13"x2.5") 4(13.25"x26.13"x4.75")							

Shelleyspeed accessories and modifications can be found on page 125-128.

Additional Warranties	
	Net Pricing
One year parts and labor contract	\$279
Two year parts and labor contract	\$523
Five year compressor warranty	
1/5 HP	\$108
1/3HP	\$128



Effective August 2011. All prices F.O.B. Mt. Pleasant, MI 48858. Prices may vary on accessories ordered from the Parts Department. Visit [www.delfield.com](http://www.delfield.com) for specification sheets.

# SPF SERIES - MOBILE FREEZER SPEED LINE MODULES



## Product Information

- 14-gauge stainless steel top standard
- 9' long cord and plug are supplied standard
- 18-gauge stainless steel exterior standard
- Electrical: 120 volt, 60 cycle, single phase
- R404A refrigerant
- Maintains 0° to 5°F temperatures
- Removable sliding lids (two per unit) standard
- Standard on 5" diameter polyurethane swivel casters
- Cold wall construction
- Stainless steel fully retractable interlock provided as standard
- Basket rack system is standard
- A wide selection of laminate colors available at no additional charge
- Laminate selection has 18-gauge galvanized base, 16-gauge coved corner supports to protect laminate
- Meets NSF2, UL and CEC standards
- One year parts and 90 day labor standard warranty. Additional warranties available, see below



SPF-52

## Specifications and Prices

MODEL NUMBER	DESCRIPTION	OVERALL			BASKET CAPACITY	STORAGE CAPACITY (CU. FT.)	AMP	HP	VOLTS	NEMA PLUG	SHIP WEIGHT	FREIGHT CLASS	LIST PRICE
		L	D	H									
<b>SHELLEYSPEED™ FREEZER MODULE</b>													
SPF-42	freezer module	42"	30"	34"	10(13.25"x20.5"x2.5") 5(13.25"x20.5"x4.75")	4.42	8.0	1/3	120	5-15P	370	100	\$12,990
SPF-52	freezer module	52"	30"	34"	15(13.25"x20.5"x2.5") 7(13.25"x20.5"x4.75")	6.60	8.0	1/3	120	5-15P	525	100	\$13,654
SPF-66	freezer module	66"	30"	34"	20(13.25"x20.5"x2.5") 10(13.25"x20.5"x4.75")	8.77	8.0	1/3	120	5-15P	550	100	\$13,986
<b>SHELLEYSPEED™ FREEZER MODULE - ELEMENTARY HEIGHT</b>													
SPF-42E	freezer module	42"	30"	30"	8(13.25"x20.5"x2.5") 4(13.25"x20.5"x4.75")	3.07	8.0	1/3	120	5-15P	370	100	\$12,990
SPF-52E	freezer module	52"	30"	30"	12(13.25"x20.5"x2.5") 6(13.25"x20.5"x4.75")	4.57	8.0	1/3	120	5-15P	525	100	\$13,654
SPF-66E	freezer module	66"	30"	30"	16(13.25"x20.5"x2.5") 8(13.25"x20.5"x4.75")	6.07	8.0	1/3	120	5-15P	550	100	\$13,986
<b>SHELLEYSPEED™ FREEZER MODULE - WIDE WIDTH</b>													
SPF-42W	freezer module	42"	35"	34"	12(13.25"x26.13"x2.5") 6(13.25"x26.13"x4.75")	5.44	8.0	1/3	120	5-15P	370	100	\$13,134
SPF-52W	freezer module	52"	35"	34"	18(13.25"x26.13"x2.5") 9(13.25"x26.13"x4.75")	8.11	8.0	1/3	120	5-15P	525	100	\$13,801
SPF-66W	freezer module	66"	35"	34"	24(13.25"x26.13"x2.5") 12(13.25"x26.13"x4.75")	10.78	8.0	1/3	120	5-15P	550	100	\$14,023
<b>SHELLEYSPEED™ FREEZER MODULE - WIDE WIDTH, ELEMENTARY HEIGHT</b>													
SPF-42EW	freezer module	42"	35"	30"	8(13.25"x26.13"x2.5") 4(13.25"x26.13"x4.75")	3.77	8.0	1/3	120	5-15P	370	100	\$13,134
SPF-52EW	freezer module	52"	35"	30"	12(13.25"x26.13"x2.5") 6(13.25"x26.13"x4.75")	5.62	8.0	1/3	120	5-15P	525	100	\$13,801
SPF-66EW	freezer module	66"	35"	30"	16(13.25"x26.13"x2.5") 8(13.25"x26.13"x4.75")	7.47	8.0	1/3	120	5-15P	550	100	\$14,023

Shelleyspeed accessories and modifications can be found on page 125-128.

Additional Warranties	
Net Pricing	
One year parts and labor contract	\$279
Two year parts and labor contract	\$523
Five year compressor warranty 1/3 H.P.	\$128



Effective August 2011. All prices F.O.B. Mt. Pleasant, MI 48858. Prices may vary on accessories ordered from the Parts Department. Visit [www.delfield.com](http://www.delfield.com) for specification sheets.

# SPRDP SERIES - MOBILE REFRIGERATED DISPLAY SPEED LINE MODULE 30" MODULE DEPTH



## Product Information



**SPRD48P-50NE**

### Display Section

- Display exterior sides are made of 18-gauge stainless steel
- Door locks standard
- ABS plastic interior sides with molded shelf supports
- (4) adjustable epoxy coated wire shelves
- On/off switch for the display section light(s)
- Top mount coil with multiple fans circulating the air throughout the cabinet
- Display section runs off a thermostatic control
- Display maintains temperatures 36° to 40° in 100° ambient
- Sliding and removable self-closing .5" thick argon filled, low-E, warm edge insert,

thermopane glass doors with left and right vertical gasket

### Base Section

- 14-gauge stainless steel top standard
- 18-gauge stainless steel exterior body
- 9' long cord and plug are supplied standard
- R404A refrigerant
- Standard on 5" diameter polyurethane casters
- Stainless steel fully retractable interlock provided as standard
- A wide selection of laminate colors available at no additional charge
- One year parts and 90 day labor standard warranty. Additional warranties available, see below

## Specifications and Prices

MODEL NUMBER	DESCRIPTION	OVERALL L	OVERALL D	OVERALL H	DISPLAY SHELF AREA SQ. FT.	DISPLAY STORAGE CUBIC FT.	AMP	HP	VOLTS	NEMA PLUG	SHIP WEIGHT	FREIGHT CLASS	LIST PRICE
<b>SHELLEYSPEED™ REFRIGERATED DISPLAY MODULE, 24" DEEP DISPLAY CASE</b>													
SPRD36P-36N	refrigerated display module, pass through	36"	30"	76"	15.4	11	12.0	1/2	115	5-15P	517	110	\$18,740
SPRD36P-50N	refrigerated display module, pass through	50"	30"	76"	15.4	11	12.0	1/2	115	5-15P	557	110	\$19,319
SPRD48P-50N	refrigerated display module, pass through	50"	30"	76"	21.3	15.1	12.0	1/2	115	5-15P	710	110	\$19,604
SPRD48P-60N	refrigerated display module, pass through	60"	30"	76"	21.3	15.1	12.0	1/2	115	5-15P	746	110	\$20,116
SPRD60P-74N	refrigerated display module, pass through	74"	30"	76"	27.2	19.3	16.0	3/4	115	5-20P	775	110	\$22,056
SPRD72P-74N	refrigerated display module, pass through	74"	30"	76"	33.2	23.5	16.0	3/4	115	5-20P	858	110	\$23,796
<b>SHELLEYSPEED™ REFRIGERATED DISPLAY MODULE, 24" DEEP DISPLAY CASE, ELEMENTARY HEIGHT</b>													
SPRD36P-36NE	refrigerated display module, pass through	36"	30"	72"	15.4	11	12.0	1/2	115	5-15P	517	110	\$18,740
SPRD36P-50NE	refrigerated display module, pass through	50"	30"	72"	15.4	11	12.0	1/2	115	5-15P	557	110	\$19,319
SPRD48P-50NE	refrigerated display module, pass through	50"	30"	72"	21.3	15.1	12.0	1/2	115	5-15P	710	110	\$19,604
SPRD48P-60NE	refrigerated display module, pass through	60"	30"	72"	21.3	15.1	12.0	1/2	115	5-15P	740	110	\$20,116
SPRD60P-74NE	refrigerated display module, pass through	74"	30"	72"	27.2	19.3	16.0	3/4	115	5-20P	775	110	\$22,056
SPRD72P-74NE	refrigerated display module, pass through	74"	30"	72"	33.2	23.5	16.0	3/4	115	5-20P	858	110	\$23,796

Shelleyspeed accessories and modifications can be found on page 125-128.

### Additional Warranties

Net Pricing

One year parts and labor contract-----	\$279
Two year parts and labor contract-----	\$523
Five year compressor warranty	
1/2 HP -----	\$139
3/4 HP -----	\$145



Effective August 2011. All prices F.O.B. Mt. Pleasant, MI 48858. Prices may vary on accessories ordered from the Parts Department. Visit [www.delfield.com](http://www.delfield.com) for specification sheets.

# SPRDP SERIES - MOBILE REFRIGERATED DISPLAY SPEED LINE MODULE 35" MODULE DEPTH



## Product Information

### Display Section

- Display exterior sides are made of 18-gauge stainless steel
- Door locks standard
- ABS plastic interior sides with molded shelf supports
- (4) adjustable epoxy coated wire shelves
- On/off switch for the display section light(s)
- Top mount coil with multiple fans circulating the air throughout the cabinet
- Display section runs off a thermostatic control
- Display maintains temperatures 36° to 40° in 100° ambient
- Sliding and removable self-closing .5" thick argon filled, low-E, warm edge insert, thermopane glass doors with left and right vertical gasket

### Base Section

- 14-gauge stainless steel top standard
- 18-gauge stainless steel exterior body
- 9' long cord and plug are supplied standard
- R404A refrigerant
- Standard on 5" diameter polyurethane casters
- Stainless steel fully retractable interlock provided as standard
- A wide selection of laminate colors available at no additional charge
- One year parts and 90 day labor standard warranty. Additional warranties available, see below



SPRD48P-50DW

## Specifications and Prices

MODEL NUMBER	DESCRIPTION	OVERALL			DISPLAY SHELF AREA SQ. FT.	DISPLAY STORAGE CUBIC FT.	AMP	HP	VOLTS	NEMA PLUG	SHIP WEIGHT	FREIGHT CLASS	LIST PRICE
		L	D	H									
<b>SHELLEYSPEED™ REFRIGERATED DISPLAY MODULE, 30" DEEP DISPLAY CASE</b>													
SPRD36P-36DW	refrigerated display module, pass through	36"	35"	76"	20.6	14.3	12.0	1/2	115	5-15P	576	110	\$20,390
SPRD36P-50DW	refrigerated display module, pass through	50"	35"	76"	20.6	14.3	12.0	1/2	115	5-15P	625	110	\$21,261
SPRD48P-50DW	refrigerated display module, pass through	50"	35"	76"	28.5	19.8	12.0	1/2	115	5-15P	789	110	\$22,206
SPRD48P-60DW	refrigerated display module, pass through	60"	35"	76"	28.5	19.8	12.0	1/2	115	5-15P	819	110	\$22,483
SPRD60P-74DW	refrigerated display module, pass through	74"	35"	76"	36.4	25.2	16.0	3/4	115	5-20P	919	110	\$24,083
SPRD72P-74DW	refrigerated display module, pass through	74"	35"	76"	44.4	30.7	16.0	3/4	115	5-20P	1095	110	\$25,804
<b>SHELLEYSPEED™ REFRIGERATED DISPLAY MODULE, 30" DEEP DISPLAY CASE, ELEMENTARY HEIGHT</b>													
SPRD36P-36DEW	refrigerated display module, pass through	36"	35"	72"	20.6	14.3	12.0	1/2	115	5-15P	576	110	\$20,390
SPRD36P-50DEW	refrigerated display module, pass through	50"	35"	72"	20.6	14.3	12.0	1/2	115	5-15P	625	110	\$21,261
SPRD48P-50DEW	refrigerated display module, pass through	50"	35"	72"	28.5	19.8	12.0	1/2	115	5-15P	789	110	\$22,206
SPRD48P-60DEW	refrigerated display module, pass through	60"	35"	72"	28.5	19.8	12.0	1/2	115	5-15P	819	110	\$22,483
SPRD60P-74DEW	refrigerated display module, pass through	74"	35"	72"	36.4	25.2	16.0	3/4	115	5-20P	919	110	\$24,083
SPRD72P-74DEW	refrigerated display module, pass through	74"	35"	72"	44.4	30.7	16.0	3/4	115	5-20P	1095	110	\$25,804

Shelleyspeed accessories and modifications can be found on page 125-128.

Additional Warranties	
Net Pricing	Net Pricing
One year parts and labor contract-----\$279	Five year compressor warranty
Two year parts and labor contract-----\$523	1/2 HP -----\$139
	3/4 HP -----\$145



SHELLEYSPEED® SERVING LINES

# SPHM SERIES - MOBILE HEATED DISPLAY SPEED LINE MODULE



## Product Information



**SPHM-64**

### Base Section

- 14-gauge stainless steel top standard
- 18-gauge stainless steel exterior body
- Base of unit has dry storage; lid rack or basket rack optional
- Hinged door(s) with black ABS recessed door handle standard
- Standard on 5" diameter polyurethane swivel casters
- Stainless steel fully retractable interlock provided as standard
- Laminate section has 18-gauge galvanized base and 16-gauge coved corner supports to protect laminate
- A wide selection of laminate colors available at no additional charge
- One year parts and 90 day labor standard warranty. Additional warranties available, see below

### Display Section

- 9' long cord and plug are supplied standard
- Top heated cabinet maintains NSF4 requirements; holds product temperatures at 140 degrees
- Two sliding doors standard, easily removable for serving period
- Cabinet interior has lighting to enhance merchandising
- Heated merchandiser accommodates 13.25"x20.5"x2.5" or 13.25"x20.5"x4.75" size baskets
- Sloped peak of heated cabinet accommodates baskets for added merchandising
- Meets UL, NSF2, NSF4 and CEC standards

## Specifications and Prices

MODEL NUMBER	DESCRIPTION	OVERALL L	OVERALL D	OVERALL H	BASKET CAPACITY (HEATED PORTION)	BASE STORAGE CAPACITY CU.FT.	AMP	VOLTS	WATTS	NEMA PLUG	SHIP WEIGHT	FREIGHT CLASS	LIST PRICE
<b>SHELLEYSPEED™ HEATED DISPLAY MODULE</b>													
SPHM-50	heated display module	50"	30"	64.9"	6(13.25"x20.5"x2.5") 3(13.25"x20.5"x4.75")	13.63	14.75	120	1770	5-20P	440	100	<b>\$18,147</b>
SPHM-64	heated display module	64"	30"	64.9"	8(13.25"x20.5"x2.5") 4(13.25"x20.5"x4.75")	18.17	16.3	120	1960	5-20P	490	100	<b>\$20,202</b>
<b>SHELLEYSPEED™ HEATED DISPLAY MODULE - ELEMENTARY HEIGHT</b>													
SPHM-50E	heated display module	50"	30"	60.9"	6(13.25"x20.5"x2.5") 3(13.25"x20.5"x4.75")	9.08	14.75	120	1770	5-20P	440	100	<b>\$18,147</b>
SPHM-64E	heated display module	64"	30"	60.9"	8(13.25"x20.5"x2.5") 4(13.25"x20.5"x4.75")	12.1	16.3	120	1960	5-20P	490	100	<b>\$20,202</b>
<b>SHELLEYSPEED™ HEATED DISPLAY MODULE - WIDE WIDTH</b>													
SPHM-50W	heated display module	50"	35"	64.9"	6(13.25"x26.13"x2.5") 3(13.25"x26.13"x4.75")	14.63	14.75	120	1770	5-20P	460	100	<b>\$18,290</b>
SPHM-64W	heated display module	64"	35"	64.9"	8(13.25"x26.13"x2.5") 4(13.25"x26.13"x4.75")	19.5	16.3	120	1960	5-20P	510	100	<b>\$20,534</b>
<b>SHELLEYSPEED™ HEATED DISPLAY MODULE - WIDE WIDTH, ELEMENTARY HEIGHT</b>													
SPHM-50EW	heated display module	50"	35"	60.9"	6(13.25"x26.13"x2.5") 3(13.25"x26.13"x4.75")	9.75	14.75	120	1770	5-20P	460	100	<b>\$18,290</b>
SPHM-64EW	heated display module	64"	35"	60.9"	8(13.25"x26.13"x2.5") 4(13.25"x26.13"x4.75")	13	16.3	120	1960	5-20P	510	100	<b>\$20,534</b>

Shelleyspeed accessories and modifications can be found on page 125-128.

### Additional Warranties

Net Pricing

One year parts and labor contract ----- \$279

Two year parts and labor contract ----- \$523



Effective August 2011. All prices F.O.B. Mt. Pleasant, MI 48858. Prices may vary on accessories ordered from the Parts Department. Visit [www.delfield.com](http://www.delfield.com) for specification sheets.

# SPM SERIES - MOBILE UTILITY (MERCHANDISING) SPEED LINE MODULES



**SPM-50**

## Product Information

- 14-gauge stainless steel top standard
  - 18-gauge stainless steel exterior body
  - Units have a single or double door dry compartment for storage
  - Standard on 5" diameter polyurethane swivel casters
  - Stainless steel fully retractable interlock provided as standard
  - A wide selection of laminate colors
- available at no additional charge
- Laminate selection has 18-gauge galvanized base, 16-gauge coved corner supports to protect laminate
  - Meets NSF2 standard
  - One year parts and 90 day labor standard warranty. Additional warranties available, see below

## Specifications and Prices

MODEL NUMBER	DESCRIPTION	OVERALL L	OVERALL D	OVERALL H	# OF DOORS	BASKET CAPACITY (BASE OF UNIT)*	LID STORAGE CAPACITY (BASE OF UNIT)*	SHIP WEIGHT	FREIGHT CLASS	LIST PRICE
<b>SHELLEYSPEED™ UTILITY (MERCHANDISING) MODULE</b>										
SPM-28	utility module	28"	30"	34"	1	8(13.25"x20.5"x2.5") 4(13.25"x20.5"x4.75")	N/A	165	125	<b>\$5,250</b>
SPM-36	utility module	36"	30"	34"	1	8(13.25"x20.5"x2.5") 4(13.25"x20.5"x4.75")	N/A	185	125	<b>\$6,057</b>
SPM-50	utility module	50"	30"	34"	2	16(13.25"x20.5"x2.5") 8(13.25"x20.5"x4.75")	14	205	125	<b>\$8,413</b>
SPM-74	utility module	74"	30"	34"	2	24(13.25"x20.5"x2.5") 12(13.25"x20.5"x4.75")	14	270	125	<b>\$9,188</b>
<b>SHELLEYSPEED™ UTILITY (MERCHANDISING) MODULE - ELEMENTARY HEIGHT</b>										
SPM-28E	utility module	28"	30"	30"	1	5(13.25"x20.5"x2.5") 2(13.25"x20.5"x4.75")	N/A	165	125	<b>\$5,250</b>
SPM-36E	utility module	36"	30"	30"	1	5(13.25"x20.5"x2.5") 2(13.25"x20.5"x4.75")	N/A	185	125	<b>\$6,057</b>
SPM-50E	utility module	50"	30"	30"	2	10(13.25"x20.5"x2.5") 5(13.25"x20.5"x4.75")	8	205	125	<b>\$8,413</b>
SPM-74E	utility module	74"	30"	30"	2	15(13.25"x20.5"x2.5") 7(13.25"x20.5"x4.75")	8	270	125	<b>\$9,188</b>
<b>SHELLEYSPEED™ UTILITY (MERCHANDISING) MODULE - WIDE WIDTH</b>										
SPM-28W	utility module	28"	35"	34"	1	8(13.25"x26.13"x2.5") 4(13.25"x26.13"x4.75")	N/A	165	125	<b>\$5,516</b>
SPM-36W	utility module	36"	35"	34"	1	8(13.25"x26.13"x2.5") 4(13.25"x26.13"x4.75")	N/A	185	125	<b>\$6,324</b>
SPM-50W	utility module	50"	35"	34"	2	16(13.25"x26.13"x2.5") 8(13.25"x26.13"x4.75")	14	205	125	<b>\$8,979</b>
SPM-74W	utility module	74"	35"	34"	2	24(13.25"x26.13"x2.5") 12(13.25"x26.13"x4.75")	14	270	125	<b>\$9,566</b>
<b>SHELLEYSPEED™ UTILITY (MERCHANDISING) MODULE - WIDE WIDTH, ELEMENTARY HEIGHT</b>										
SPM-28EW	utility module	28"	35"	30"	1	5(13.25"x20.5"x2.5") 2(13.25"x20.5"x4.75")	N/A	165	125	<b>\$5,516</b>
SPM-36EW	utility module	36"	35"	30"	1	5(13.25"x20.5"x2.5") 2(13.25"x20.5"x4.75")	N/A	185	125	<b>\$6,324</b>
SPM-50EW	utility module	50"	35"	30"	2	10(13.25"x20.5"x2.5") 5(13.25"x20.5"x4.75")	8	205	125	<b>\$8,979</b>
SPM-74EW	utility module	74"	35"	30"	2	15(13.25"x20.5"x2.5") 7(13.25"x20.5"x4.75")	8	270	125	<b>\$9,566</b>

\*Only if ordering the lid or basket storage module.

Shelleyspeed accessories and modifications can be found on page 125-128.

Additional Warranties	
One year parts and labor contract	Net Pricing ----- \$279
Two year parts and labor contract	----- \$523





# SPCS SERIES - MOBILE CASHIER SPEED LINE MODULES



**SPCS-30**

## Product Information

- 14-gauge stainless steel top standard
- 18-gauge stainless steel exterior standard
- Full NSF and UL certification
- A wide selection of laminate colors available at no additional charge
- Standard on 5" diameter polyurethane swivel casters
- Stainless steel fully retractable interlock provided as standard
- A 3" grommet hole is located at the rear of the top to allow cord access for cash register
- Stainless steel locking cash drawer standard
- Stainless steel under shelf can serve as foot rest or storage
- Add eye catching decal packages or bright canopies to create a distinctive look
- Laminate selection has 18-gauge galvanized base, 16-gauge coved corner supports to protect laminate
- One year parts and 90 day labor standard warranty. Additional warranties available, see below

## Specifications and Prices

MODEL NUMBER	DESCRIPTION	OVERALL			SHIP WEIGHT	FREIGHT CLASS	LIST PRICE
		L	D	H			
<b>SHELLEYSPEED™ CASHIER COUNTER MODULE</b>							
SPCS-30	cashier counter module	30"	30"	34"	180	100	\$5,582
SPCS-36	cashier counter module	36"	30"	34"	210	100	\$6,228
<b>SHELLEYSPEED™ CASHIER COUNTER MODULE - ELEMENTARY HEIGHT</b>							
SPCS-30E	cashier counter module	30"	30"	30"	180	100	\$5,582
SPCS-36E	cashier counter module	36"	30"	30"	210	100	\$6,228
<b>SHELLEYSPEED™ CASHIER COUNTER MODULE - WIDE WIDTH</b>							
SPCS-30W	cashier counter module	30"	35"	34"	190	100	\$5,788
SPCS-36W	cashier counter module	36"	35"	34"	220	100	\$6,228
<b>SHELLEYSPEED™ CASHIER COUNTER MODULE - WIDE WIDTH, ELEMENTARY HEIGHT</b>							
SPCS-30EW	cashier counter module	30"	35"	30"	190	100	\$5,788
SPCS-36EW	cashier counter module	36"	35"	30"	220	100	\$6,228

Shelleyspeed accessories and modifications can be found on page 125-128.

### Additional Warranties

Net Pricing

One year parts and labor contract----- \$279

Two year parts and labor contract----- \$523





**SPH - HEATED SPEED LINE SERVING MODULES**

**SPR - REFRIGERATED SPEED LINE SERVING MODULES**

		-40	-50	-64	-40W	-50W	-64W
<b>SPA.</b>	12" stainless steel V fold-down tray slide -----	\$941	\$1,105	\$1,412	\$941	\$1,105	\$1,412
<b>SPB.</b>	12" stainless steel "V" style, 14-gauge fold-down tray slide	\$941	\$1,105	\$1,412	\$941	\$1,105	\$1,412
<b>SPC.</b>	10" three-bar tubular fold-down tray slide-----	\$705	\$884	\$1,100	\$705	\$884	\$1,100
<b>SPD.</b>	10" composite fold-down cutting board -----	\$969	\$1,034	\$1,329	\$969	\$1,034	\$1,329
<b>SPE.</b>	10" stainless steel fold-down work shelf -----	\$844	\$1,040	\$1,332	\$844	\$1,040	\$1,332
<b>SPF.</b>	Line-up interlock device-----	N/C	N/C	N/C	N/C	N/C	N/C
<b>SPFL.</b>	Flourescent light (in overstructures)- -----	\$473	\$540	\$677	\$473	\$540	\$677
<b>SPHEO.</b>	208V electrical -----	\$743	\$743	\$743	\$743	\$743	\$743
<b>SPJ.</b>	12" stainless steel overshef, 18-gauge, (W models are 18")	\$687	\$872	\$1,015	\$726	\$915	\$1,063
<b>SPJ2.</b>	12" stainless steel overshef, two tier, (W models are 18") ----	\$1,370	\$1,745	\$2,030	\$1,451	\$1,828	\$2,124
<b>SPKD.</b>	Double service flip-up sneeze guard -----	\$1,815	\$1,885	\$2,322	\$2,003	\$1,885	\$2,603
<b>SPSMS.</b>	Single tier merchandising shelf -----	\$1,814	\$1,934	\$2,016	\$1,949	\$2,069	\$2,150
<b>SPDMS.</b>	Double tier merchandising shelf -----	\$2,621	\$2,739	\$2,821	\$2,755	\$2,875	\$2,957
<b>SPU.</b>	14" x 30" stainless steel end drop shelf -----	\$659	\$659	\$659	N/A	N/A	N/A
<b>SPUW.</b>	14" x 35" stainless steel end drop shelf -----	N/A	N/A	N/A	\$711	\$711	\$711
<b>SPV.</b>	Adjustable stainless steel bullet feet -----	N/C	N/C	N/C	N/C	N/C	N/C

**SPRH - REFRIGERATED/HEATED SPEED LINE COMBINATION MODULES**

**SPRF - REFRIGERATOR/FREEZER SPEED LINE COMBINATION MODULES**

		-68	-68W
<b>SPA.</b>	12" stainless steel V fold-down tray slide -----	\$1,500	\$1,500
<b>SPB.</b>	12" stainless steel "V" style, 14-gauge fold-down tray slide	\$1,500	\$1,500
<b>SPC.</b>	10" three-bar tubular fold-down tray slide-----	\$1,167	\$1,167
<b>SPD.</b>	10" composite fold-down cutting board -----	\$1,413	\$1,413
<b>SPE.</b>	10" stainless steel fold-down work shelf -----	\$1,420	\$1,420
<b>SPF.</b>	Line-up interlock device-----	N/C	N/C
<b>SPFL.</b>	Flourescent light (in overstructures)- -----	\$711	\$711
<b>SPHEO.</b>	208V electrical -----	\$743	\$743
<b>SPJ.</b>	12" stainless steel overshef, 18-gauge, (W models are 18")	\$1,077	\$1,118
<b>SPJ2.</b>	12" stainless steel overshef, two tier, (W models are 18") ----	\$2,155	\$2,237
<b>SPKD.</b>	Double service flip-up sneeze guard -----	\$2,564	\$2,753
<b>SPSMS.</b>	Single tier merchandising shelf -----	\$2,096	\$2,231
<b>SPDMS.</b>	Double tier merchandising shelf -----	\$2,902	\$3,037
<b>SPU.</b>	14" x 30" stainless steel end drop shelf -----	\$659	N/A
<b>SPUW.</b>	14" x 35" stainless steel end drop shelf -----	N/A	\$711
<b>SPV.</b>	Adjustable stainless steel bullet feet -----	N/C	N/C

# SHELLEYSPEED® EQUIPMENT ACCESSORIES

## SPF - FREEZER SPEED LINE SERVING MODULES

		-42	-52	-66	-42W	-52W	-66W
<b>SPA.</b>	12" stainless steel V fold-down tray slide -----	\$986	\$1,147	\$1,455	\$986	\$1,147	\$1,455
<b>SPB.</b>	12" stainless steel "V" style, 14-gauge fold-down tray slide	\$986	\$1,147	\$1,455	\$986	\$1,147	\$1,455
<b>SPC.</b>	10" three-bar tubular fold-down tray slide-----	\$742	\$920	\$1,134	\$742	\$920	\$1,134
<b>SPD.</b>	10" composite fold-down cutting board -----	\$1,019	\$1,076	\$1,371	\$1,019	\$1,076	\$1,371
<b>SPE.</b>	10" stainless steel fold-down work shelf -----	\$886	\$1,082	\$1,374	\$886	\$1,082	\$1,374
<b>SPF.</b>	Line-up interlock device-----	N/C	N/C	N/C	N/C	N/C	N/C
<b>SPFL.</b>	Flourescent light (in overstructures)------	\$473	\$540	\$677	\$473	\$540	\$677
<b>SPJ.</b>	12" stainless steel overshef, 18-gauge, (W models are 18")	\$719	\$908	\$1,048	\$759	\$947	\$1,087
<b>SPJ2.</b>	12" stainless steel overshef, two tier, (W models are 18") ----	\$1,441	\$1,814	\$2,094	\$1,519	\$1,895	\$2,175
<b>SPKD.</b>	Double service flip-up sneeze guard -----	\$1,907	\$1,962	\$2,491	\$2,176	\$2,231	\$2,759
<b>SPSMS.</b>	Single tier merchandising shelf -----	\$1,906	\$2,012	\$2,079	\$2,040	\$2,146	\$2,212
<b>SPDMS.</b>	Double tier merchandising shelf -----	\$2,712	\$2,818	\$2,885	\$2,712	\$2,952	\$3,019
<b>SPU.</b>	14" x 30" stainless steel end drop shelf-----	\$659	\$659	\$659	N/A	N/A	N/A
<b>SPUW.</b>	14" x 35" stainless steel end drop shelf-----	N/A	N/A	N/A	\$711	\$711	\$711
<b>SPV.</b>	Adjustable stainless steel bullet feet -----	N/C	N/C	N/C	N/C	N/C	N/C

## SPRD-REFRIGERATED DISPLAY CASE SPEED LINE MODULE

<b>SPCSH</b>	10" x 30" stainless steel cash shelf -----	\$705
<b>SPCSHW</b>	10" x 35" stainless steel cash shelf -----	\$744
<b>SPS</b>	Additional shelf for display -----	
	<b>A.</b> 36" -----	\$188 each
	<b>B.</b> 48" -----	\$238 each
	<b>C.</b> 60" -----	\$265 each
	<b>D.</b> 72" -----	\$302 each
<b>SPU</b>	14" x 30" stainless steel end drop shelf-----	\$659
<b>SPUW</b>	14" x 35" stainless steel end drop shelf-----	\$711
	230 volt, 50 cycle system -----	\$711

## SPHM - HEATED MERCHANDISER SPEED LINE SERVING MODULES

		-50	-64	-50W	-64W
<b>SPA.</b>	12" stainless steel V fold-down tray slide -----	\$1,105	\$1,412	\$1,105	\$1,412
<b>SPBSL.</b>	Base storage lids-----	\$1,157	\$1,399	\$1,280	\$1,516
<b>SPBSB.</b>	Base storage baskets -----	\$1,157	\$1,399	\$1,280	\$1,516
<b>SPC.</b>	10" three-bar tubular fold-down tray slide-----	\$884	\$1,100	\$884	\$1,100
<b>SPD.</b>	10" composite fold-down cutting board -----	\$1,034	\$1,329	\$1,034	\$1,329
<b>SPE.</b>	10" stainless steel fold-down work shelf -----	\$1,040	\$1,332	\$1,040	\$1,332
<b>SPF.</b>	Line-up interlock device-----	N/C	N/C	N/C	N/C
<b>SPU.</b>	14" x 30" stainless steel end drop shelf-----	\$659	\$659	N/A	N/A
<b>SPUW.</b>	14" x 35" stainless steel end drop shelf -----	N/A	N/A	\$711	\$711
<b>SPV.</b>	Adjustable stainless steel bullet feet -----	N/C	N/C	N/C	N/C



**SPM - UTILITY SPEED LINE MODULE**

		-28	-36	-50	-60	-74
<b>SPA.</b>	12" stainless steel V fold-down tray slide -----	\$782	\$921	\$1,105	\$1,325	\$1,634
<b>SPB.</b>	12" stainless steel "V" style, 14-gauge fold-down tray slide	\$782	\$921	\$1,105	\$1,105	\$1,634
<b>SPBSL.</b>	Base storage for lids -----	N/A	N/A	\$1,157	\$1,399	\$1,399
<b>SPBSB.</b>	Base storage for baskets-----	\$866	\$978	\$1,157	\$1,399	\$1,399
<b>SPC.</b>	10" three-bar tubular fold-down tray slide-----	\$492	\$634	\$884	\$1,046	\$1,255
<b>SPD.</b>	10" composite fold-down cutting board -----	\$782	\$928	\$1,034	\$1,280	\$1,506
<b>SPE.</b>	10" stainless steel fold-down work shelf -----	\$600	\$774	\$1,040	\$1,245	\$1,546
<b>SPF.</b>	Line-up interlock device-----	N/C	N/C	N/C	N/C	N/C
<b>SPJ.</b>	12" stainless steel overshef, 18-gauge -----	\$468	\$602	\$872	\$946	\$1,321
<b>SPJ2.</b>	12" stainless steel overshef, two tier -----	\$936	\$1,202	\$1,745	\$1,895	\$2,643
<b>SPKD.</b>	Double service flip-up sneeze guard -----	\$1,284	\$1,651	\$1,885	\$2,266	\$2,806
<b>SPQ.*</b>	115/15A outlet with 10A breaker -----	\$771	\$771	\$771	\$771	\$771
<b>SPSMS.</b>	Single tier merchandising shelf -----	\$1,748	\$1,780	\$1,934	\$1,982	\$2,150
<b>SPDMS.</b>	Double tier merchandising shelf -----	\$2,555	\$2,586	\$2,739	\$2,821	\$2,957
<b>SPU.</b>	14" x 30" stainless steel end drop shelf -----	\$659	\$659	\$659	\$659	\$659
<b>SPV.</b>	Adjustable stainless steel bullet feet -----	N/C	N/C	N/C	N/C	N/C

*\*Inclusion of these options will alter the electrical specifications of unit.*

**SPMW - UTILITY SPEED LINE MODULE**

		-28W	-36W	-50W	-60W	-74W
<b>SPA.</b>	12" stainless steel V fold-down tray slide -----	\$782	\$921	\$1,105	\$1,325	\$1,634
<b>SPB.</b>	12" stainless steel "V" style, 14-gauge fold-down tray slide	\$782	\$921	\$1,105	\$1,105	\$1,634
<b>SPBSL.</b>	Base storage lids-----	N/A	N/A	\$1,280	\$1,516	\$1,516
<b>SPBSB.</b>	Base storage baskets -----	\$925	\$1,042	\$1,280	\$1,516	\$1,516
<b>SPC.</b>	10" three-bar tubular fold-down tray slide-----	\$492	\$634	\$884	\$1,046	\$1,255
<b>SPD.</b>	10" composite fold-down cutting board -----	\$782	\$928	\$1,034	\$1,280	\$1,506
<b>SPE.</b>	10" stainless steel fold-down work shelf -----	\$600	\$774	\$1,040	\$1,245	\$1,546
<b>SPF.</b>	Line-up interlock device-----	N/C	N/C	N/C	N/C	N/C
<b>SPJ.</b>	18" stainless steel overshef, 18-gauge -----	\$468	\$602	\$915	\$946	\$1,321
<b>SPJ2.</b>	18" stainless steel overshef, two tier -----	\$936	\$1,202	\$1,828	\$1,895	\$2,643
<b>SPKD.</b>	Double service flip-up sneeze guard -----	\$1,284	\$1,651	\$1,885	\$2,266	\$2,806
<b>SPQ.*</b>	115/15A outlet with 10A breaker -----	\$771	\$771	\$771	\$771	\$771
<b>SPSMS.</b>	Single tier merchandising shelf -----	\$1,882	\$1,915	\$2,069	\$2,117	\$2,285
<b>SPDMS.</b>	Double tier merchandising shelf -----	\$2,688	\$2,722	\$2,875	\$2,923	\$3,091
<b>SPUW.</b>	14" x 35" stainless steel end drop shelf -----	\$711	\$711	\$711	\$711	\$711
<b>SPV.</b>	Adjustable stainless steel bullet feet -----	N/C	N/C	N/C	N/C	N/C

*\*Inclusion of these options will alter the electrical specifications of unit.*

# SHELLEYSPEED® EQUIPMENT ACCESSORIES

## SPCS - CASHIER STAND SPEED LINE MODULE

-30

<b>SPA.</b>	12" stainless steel "V" fold-down tray slide -----	<b>\$926</b>
<b>SPB.</b>	12" stainless steel "V" style, 14-gauge fold-down tray slide	<b>\$926</b>
<b>SPC.</b>	10" three-bar tubular fold-down tray slide-----	<b>\$3,981</b>
<b>SPD.</b>	10" composite fold-down cutting board -----	<b>\$928</b>
<b>SPE.</b>	10" stainless steel fold-down work shelf -----	<b>\$774</b>
<b>SPF.</b>	Line-up interlock device-----	<b>N/C</b>
<b>SPPAN3.</b>	(3) 1/3 x 6" deep pans-----	<b>\$772</b>
<b>SPQ.*</b>	115/15A outlet with 10A breaker-----	<b>\$771</b>
<b>SPSW6.</b>	(6) Silverware cutouts w/plastic bins -----	<b>\$738</b>
<b>SPSW8.</b>	(8) Silverware cutouts w/plastic bins -----	<b>\$884</b>
<b>SPSW8-PI</b>	(8) Silverware cutouts w/plastic and (1) 1/3x6" deep pan	<b>\$1,231</b>
<b>SPSW10.</b>	(10) Silverware cutouts w/plastic bins -----	<b>\$1,027</b>
<b>SPU.</b>	14" x 30" stainless steel end drop shelf-----	<b>\$659</b>
<b>SPUW.</b>	14" x 35" stainless steel end drop shelf-----	<b>\$711</b>
<b>SPV.</b>	Adjustable stainless steel bullet feet -----	<b>N/C</b>

\*Inclusion of these options will alter the electrical specifications of unit.

## MISCELLANEOUS ACCESSORIES

<b>SPB30-4</b>	4" wire basket chrome plated (13.25" x 20.5" x 4.75") .....	<b>\$230 each</b>
<b>SPB30-2</b>	2" wire basket chrome plated (13.25" x 20.5" x 2.5") .....	<b>\$214 each</b>
<b>SPB35-4</b>	4" wire basket chrome plated (13.25" x 26.13" x 4.75") .....	<b>\$370 each</b>
<b>SPB35-2</b>	2" wire basket chrome plated (13.25" x 26.13" x 2.5").....	<b>\$349 each</b>
<b>SPBFF</b>	French fry basket for heated merchandiser (13.25" x 20.5" x 2.2") .....	<b>\$79 each</b>
<b>SP22B</b>	Slanted overshelves, double sided (per foot, 3' minimum).....	<b>\$2,558</b>
<b>SPDP</b>	Decal packages.....	<b>CONTACT FACTORY</b>
<b>SP25</b>	Canopy and accessories	
	<b>A.</b> Dome style .....	<i>Per inch</i> <b>\$57</b>
	<b>B.</b> Peak style.....	<i>Per inch</i> <b>\$82</b>
	<b>C.</b> Bus style.....	<i>Per inch</i> <b>\$40</b>
	<b>D.</b> Stationary frame.....	<b>\$1,401</b>
	<b>E.</b> Adjustable (tube in tube) frame.....	<b>\$2,679</b>
	<b>F.</b> 3" letters.....	<i>Each</i> <b>\$33</b>
	<b>G.</b> 2" or 3" stripe on canopy .....	<i>Per inch</i> <b>\$33</b>
<b>SPBD-30</b>	Basket dolly 30" deep units.....	<b>\$878</b>
<b>SPBD-35</b>	Basket dolly 35" deep units.....	<b>\$918</b>





**N, N6/N10/N14** - Milk or Beverage  
Dispensers

**NDF** - Milk or Beverage Dispensers

**NLFAC** - Milk or Beverage Dispensers

**KCM/KCFM** - Milk and Ice Cream  
Dispensers

**SCM/SCFM** - Milk and Ice Cream  
Dispensers

**SCF & NSCF** - Milk and Ice Cream  
Dispensers



# N, N6/N10/N14 AND NDF SERIES - MILK AND BEVERAGE DISPENSERS

MILK COOLERS



**N-860**

Unit shown with optional casters



**N10-1313-34**

Unit shown with optional casters

### Laminate & Fiberglass Pricing Chart

Must specify color selection on order.

MODEL	LAMINATE PRICE	FIBERGLASS PANEL PRICE
N-520	\$576	\$753
N-860	\$629	\$800
N-1200	\$678	\$873
N-1530	\$730	\$919
N6	\$624	\$899
N10	\$691	\$879
N14	\$756	\$628
NDF-12	\$839	\$1,013
NDF-18	\$839	\$940

### Wire Basket Pricing

MODEL	# OF BASKETS	LIST PRICE
N-520	9	\$996
N-860	15	\$1,661
N-1200	21	\$2,325
N-1530	27	\$2,989

### Additional Warranties

Net Pricing

One year parts and labor contract -----	\$279
Two year parts and labor contract -----	\$523
Five year compressor warranty 1/4 H.P. -----	\$108
1/3 H.P. -----	\$128

## Product Information

### N SERIES ONLY

- Six anodized aluminum divider trays per opening except opening over compressor, (2) supplied over compressor
- Refrigeration system shall be HFC-134A refrigerant
- One year parts and 90 day labor standard warranty. Additional warranties available, see below

### N6/N10/N14 SERIES ONLY

- Cabinet top and corners to be 16-gauge stainless steel
- Cabinet sides to be 22-gauge stainless steel
- Interior liner to be water tight 22-gauge stainless steel
- 1" IPS drain
- Units insulated with foamed in place polyurethane
- Units to have sliding stainless steel lids with recessed handle
- Self-leveling mechanisms shall be adjustable by adding and removing stainless steel extension springs located inside the elevator housing
- Dispenser platform carrier shall be 18-gauge stainless steel and removable for cleaning
- 6" adjustable stainless steel legs
- Refrigeration system shall be HFC-134A refrigerant
- Expansion valve and pressure control

- Cabinet temperatures maintain 36°F to 40°F (2°C to 4°C)
- 9' cord and plug
- One year parts and 90 day labor standard warranty. Additional warranties available, see below

### NDF SERIES ONLY

- Cabinet exterior to be 20-gauge stainless steel
- Cabinet sides to be 18-gauge stainless steel
- Interior liner to be water-tight 22-gauge stainless steel
- 1" IPS drain
- Units insulated with foamed in place polyurethane
- Two lids standard, one lift up and one fold down with door lock
- (4) 4.00" diameter polyolefin swivel casters (all locking)
- Non-marring gray corner bumpers
- Digital solar thermometer
- Refrigeration system shall be HFC-134A refrigerant
- Expansion valve and pressure control
- Cabinet temperatures maintain 36°F to 40°F (2°C to 4°C)
- 9' cord and plug
- One year parts and 90 day labor standard warranty. Additional warranties available, see below

## Specifications and Prices

MODEL NUMBER	DIMENSIONS			CAPACITY	H.P.	AMP	VOLTS	NEMA PLUG	SHIP WEIGHT	FREIGHT CLASS	LIST PRICE	
	L	D	H									
<b>FREE-STANDING MILK OR BEVERAGE DISPENSERS—40°F STORAGE ONLY</b>												
N-520	29"	28"	36"	240	1/4	5.0	120	5-15P	327	110	<b>\$14,317</b>	
N-860	42"	28"	36"	408	1/4	5.0	120	5-15P	392	110	<b>\$16,080</b>	
N-1200	55"	28"	36"	576	1/4	5.0	120	5-15P	462	110	<b>\$17,765</b>	
N-1530	68"	28"	36"	744	1/4	5.0	120	5-15P	532	110	<b>\$20,012</b>	
N6-1313-34	36"	32"	34"	6	1/4	5.0	120	5-15P	382	110	<b>\$14,418</b>	
N6-1313-36	36"	32"	36"	6	1/4	5.0	120	5-15P	402	110	<b>\$14,495</b>	
N10-1313-34	54.5"	32"	34"	10	1/4	5.0	120	5-15P	545	110	<b>\$17,707</b>	
N10-1313-36	54.5"	32"	36"	10	1/4	5.0	120	5-15P	565	110	<b>\$17,807</b>	
N14-1313-34	73"	32"	34"	14	1/4	5.0	120	5-15P	650	110	<b>\$21,013</b>	
N14-1313-36	73"	32"	36"	14	1/4	5.0	120	5-15P	670	110	<b>\$21,109</b>	
NDF-12	35.88"	33.38"	57"	12	1/4	5.0	120	5-15P	365	110	<b>\$12,433</b>	
NDF-18	49.88"	33.38"	57"	18	1/3	7.0	120	5-15P	430	110	<b>\$13,088</b>	

## Accessories and Modifications

Wrap-around bumpers (N-520 only; adds 1.75" to length and depth) -----	\$469
Wrap-around bumpers (N-860, N6, NDF-12 only; adds 1.75" to length and depth) -----	\$607
Wrap-around bumpers (N-1200, N10, NDF-18 only; adds 1.75" to length and depth) -----	\$748
Wrap-around bumpers (N-1530 and N14 only; adds 1.75" to length and depth) -----	\$879
(4) 5" diameter casters (heavy-duty polyurethane) with corner bumpers (4 locking; N & N6/N10/N14 only adds 1.75" to L & D) -----	\$698
Lid locking device (N & N6/N10/N14 only; specify unit) -----	\$624
Dial-style or digital-style thermometer -----	\$680
220 volt, 50/60 cycle, single phase electrical connections -----	\$973
Wire basket (N only; per three; see chart at right) -----	\$332
6" high adjustable stainless steel legs (NDF units only; specify on original order) -----	N/C
Omit elevators (N6, N10 and N14 models only)	
N6 -----	credit \$326
N10 -----	credit \$660
N14 -----	credit \$991
Plastic air curtain opening on NDF models -----	\$638
Stainless steel divider tray (each) -----	\$34



# NLFAC SERIES - MILK OR BEVERAGE DISPENSER

## Product Information

- Cabinet to be 18-gauge stainless steel
- Cabinet bottom to be 14-gauge stainless steel
- Interior liner to be water-tight 22-gauge stainless steel
- 1" diameter drain
- Units insulated with foamed in place polyurethane
- (2) Hinged lids with locks, molded of black ABS plastic
- 16-gauge dividers self locate milk crates
- Patented "air curtain" design
- (2) Evaporator coils
- Refrigeration system to be HFC-134A
- Expansion valve, thermostat and defrost timer standard
- Refrigerated temperatures maintain 36°F to 40°F (2°C to 4°C)
- Product will maintain 40°F (4°C) for 2 hours with lids open
- (4) 5.00" diameter polyolefin swivel casters (all locking)
- 8' cord and plug supplied
- One year parts and 90 days labor warranty. Additional warranties available



**NLFAC-12**

## Specifications and Prices

MODEL NUMBER	DIMENSIONS			CAPACITY	H.P.	AMP	VOLTS	NEMA PLUG	SHIP WEIGHT	FREIGHT CLASS	WTY NET	LIST PRICE
	L	D	H									
<b>FREE-STANDING MILK OR BEVERAGE DISPENSERS — 40°F STORAGE ONLY</b>												
With "air curtain" opening												
<b>NLFAC-8</b>	40"	32"	42.5"	8	1/3	7.0	115	5-15P	401	110	\$75	<b>\$14,155</b>
<b>NLFAC-12</b>	54"	32"	42.5"	12	1/2	9.0	115	5-15P	491	110	\$81	<b>\$15,370</b>
<b>NLFAC-16</b>	68"	32"	42.5"	16	1/2	11.0	115	5-15P	583	110	\$86	<b>\$16,314</b>

## Accessories and Modifications

Fiberglass accent panels, front and both sides (NLFAC only; specify color)	
NLFAC-8	\$583
NLFAC-12	\$600
NLFAC-16	\$622
220V, 50/60 cycle, single phase electrical connections	\$920
Wrap around bumpers (NLFAC only adds 1.75" to length and depth)	
NLFAC-8	\$607
NLFAC-12	\$748
NLFAC-16	\$879
Laminate exterior (specify manufacturer and color)	
NLFAC-8	\$427
NLFAC-12	\$445
NLFAC-16	\$462

### Additional Warranties

Net Pricing

One year parts and labor contract ----- \$279

Two year parts and labor contract ----- \$523

Five year compressor warranty  
1/3 H.P. ----- \$128  
1/2 H.P. ----- \$139



# KCM SERIES - MILK COUNTERS

## KCFM SERIES - MILK AND ICE CREAM COUNTERS

## SCM SERIES - SHELLEYSSTEEL MILK COUNTERS

## SCFM SERIES - SHELLEYSSTEEL MILK AND ICE CREAM CABINETS



**KCM-50**

Shown with the following option:  
C. tubular fold down tray slide



**KCFM-50**



**SCM-50**

### Product Information

- All corners and center sides reinforced with galvanized bracing
  - Full NSF and UL Certification
  - 14-gauge tops
  - All units are standard on 5" diameter swivel casters for easy cleaning and mobility
  - Easy to use interlock system is standard on base and tray slides
  - Enclosed bases for vermin control
  - A maximum 10' long cord and plug are supplied standard
  - Top has one; two, three or four die stamped openings and is provided with hinged stainless steel removable lids
  - Watertight inner liner has radius corners for easy cleaning
  - Equipped with a drain plumbed to a drain valve
  - Refrigerated compartment is equipped with automatic self-leveling, field adjustable elevators. Divider trays are supplied
  - Milk capacities are based on half pint, 2.75" x 2.75" gable top cartons
  - 60 hertz, single phase electrical standard
  - All body cutouts reinforced with 14-gauge channel supports
  - Easy to use interlock system is standard on base and tray slides
  - Easily modified with a complete array of standard accessories
  - One year parts and 90 day labor standard warranty. Additional warranties available, see below
- KCM / KCFM SERIES ONLY**
- HFC-13A refrigerant is standard
  - One piece, molded fiberglass pylon (base), fully rounded corners
  - Permanent color
  - Fire Code rating on fiberglass, laminate, canopy materials
  - Caster mounting plates laminated into base
  - Add eye catching decal packages to create a distinctive look!
- SCM / SCFM SERIES ONLY**
- Milk capacities are based on half pint, 2.75" x 2.75" gable top cartons
  - HFC-134A refrigerant is standard
  - 18-gauge stainless steel exterior body
  - 14-gauge galvanized bottom
  - Top has one; two, three or four die stamped openings and is provided with hinged stainless steel removable lids

### Specifications and Prices - Shelleyglas

MODEL NUMBER	LID(S)	DESCRIPTION	L	D	H	AMP	H.P.	VOLTS	NEMA PLUG	SHIP WEIGHT	FREIGHT CLASS	LIST PRICE
<b>SHELLEYGLAS MILK COUNTERS—40°F STORAGE ONLY</b>												
KCM-36	1	126 cartons	36"	30"	36"	5.0	1/4	115	5-15P	400	92.5	\$11,950
KCM-50	2	252 cartons	50"	30"	36"	5.0	1/4	115	5-15P	450	92.5	\$13,846
KCM-60	3	378 cartons	60"	30"	36"	5.0	1/4	115	5-15P	500	92.5	\$15,264
KCM-74	4	504 cartons	74"	30"	36"	5.0	1/4	115	5-15P	550	92.5	\$17,796
<b>SHELLEYGLAS MILK AND ICE CREAM COUNTERS—40°F AND 0°F STORAGE ONLY</b>												
KCFM-50	2	126 cartons or 210 cups	50"	30"	36"	7.1	1/4	115	5-15P	500	92.5	\$15,860
KCFM-74	4	252 cartons or 420 cups	74"	30"	36"	8.0	1/3	115	5-15P	590	92.5	\$20,630

Shelleyglas accessories and modifications can be found on page 105-114.

### Specifications and Prices - Shelleysteel

MODEL NUMBER	LID(S)	CAPACITY	L	D	H	AMP	H.P.	VOLTS	NEMA PLUG	SHIP WEIGHT	FREIGHT CLASS	LIST PRICE
<b>SHELLEYSTEEL MILK COUNTERS—40°F STORAGE ONLY</b>												
SCM-36	1	126 cartons	36"	30"	36"	5.0	1/4	115	5-15P	400	92.5	\$9,633
SCM-50	2	252 cartons	50"	30"	36"	5.0	1/4	115	5-15P	450	92.5	\$13,404
SCM-60	3	378 cartons	60"	30"	36"	5.0	1/4	115	5-15P	500	92.5	\$15,671
SCM-74	4	504 cartons	74"	30"	36"	5.0	1/4	115	5-15P	550	92.5	\$18,285
<b>SHELLEYSTEEL MILK AND ICE CREAM COUNTERS—40°F AND 0°F STORAGE ONLY</b>												
SCFM-50	2	126 cartons or 210 cups	50"	30"	36"	7.1	1/4	115	5-15P	500	92.5	\$16,728
SCFM-74	4	252 cartons or 420 cups	74"	30"	36"	8.0	1/3	115	5-15P	590	92.5	\$21,754

Shelleyglas accessories and modifications can be found on page 105-114.

#### Additional Warranties

Net Pricing	
One year parts and labor contract -----	\$279
Two year parts and labor contract ----	\$523
Five year compressor warranty	
1/4 H.P. -----	\$108
1/3 H.P. -----	\$128



# SCF AND NSCF - MILK AND ICE CREAM DISPENSERS

## Product Information

- Cabinet top and corners to be 16-gauge stainless steel
- Cabinet sides to be 22-gauge stainless steel
- 1.25" IPS drain
- Units insulated with foamed in place high density polyurethane
- Insulated folding lid, stainless steel and high impact plastic
- Self-leveling mechanisms shall be adjustable by adding and removing stainless steel extension springs located inside the elevator housing
- Dispenser platform carrier shall be 18-gauge stainless steel and removable for cleaning
- (6) Anodized aluminum divider trays per opening (no divider trays supplied in opening over compressor)
- 6" adjustable stainless steel legs
- Environmentally friendly HFC-404A refrigerant
- 9' cord and plug supplied
- One year parts and 90 day labor standard warranty. Additional warranties available, see below

### SCF SERIES ONLY

- Interior liner to be watertight 22-gauge stainless steel
- Expansion valve
- Cabinet shall maintain 0°F to 5°F (-18°C to -15°C) with lids closed
- Pressure control located near the condensing unit

### NSCF SERIES ONLY

- (2) Interior liners to be water tight 22-gauge stainless steel- (1) freezer and (1) refrigerator
- (2) expansion valves, EPR valve (refrigerated section) and pressure control (freezer)
- Refrigerated temperatures maintain 36°F to 40°F (2°C to 4°C)
- Freezer temperatures maintain 0°F to 5°F (-18°C to -15°C)



**SCF-32**  
Shown with optional corner bumpers & casters

## Laminate & Fiberglass Pricing Chart

Must specify color selection on order.

MODEL	LAMINATE PRICE	FIBERGLASS PANEL PRICE
SCF-32	\$580	\$754
SCF-48	\$635	\$822
NSCF-48	\$635	\$821

## Specifications and Prices

MODEL NUMBER	DIMENSIONS			CAPACITY	H.P.	AMP	VOLTS	NEMA PLUG	SHIP WEIGHT	FREIGHT CLASS	LIST PRICE
	L	D	H								
<b>FREE-STANDING ICE CREAM DISPENSERS — 0°F STORAGE ONLY</b>											
<b>Self-contained</b>											
SCF-32	32.5"	28"	37"	300	1/4	7.1	120	5-15P	334	110	\$13,566
SCF-48	48"	28"	37"	510	1/3	8.0	120	5-15P	414	110	\$15,909
<b>FREE-STANDING MILK &amp; ICE CREAM DISPENSERS — 0°F OR 40°F STORAGE</b>											
<b>Self-contained</b>											
NSCF-48	48"	28"	37"	126/210	1/4	7.1	120	5-15P	390	110	\$16,866

## Wire Basket Pricing

MODEL	# OF BASKETS	LIST PRICE
SCF-32	9	\$944
SCF-48	12	\$1,259
NSCF-48	15	\$1,573

## Accessories and Modifications

Wrap-around bumpers (SCF-32 only; adds 1.75" to length and depth) -----	\$579
Wrap-around bumpers (SCF-48 & NSCF-48 only; adds 1.75" to length and depth)-----	\$702
Four 4" diameter heavy duty polyurethane casters with corner bumpers (SCF & NSCF only adds 1.75" to L & D) ---	\$555
Lid locking device (specify unit) -----	\$593
220 volt, 50/60 cycle, single phase electrical connections-----	\$928
LEXAN lid -----	\$506
Wire basket (per three; see chart on left) -----	\$315

## Additional Warranties

	Net Pricing
One year parts and labor contract -----	\$279
Two year parts and labor contract -----	\$523
Five year compressor warranty	
1/4 H.P. -----	\$108
1/3 H.P. -----	\$128



**SCN** - Trimline All Purpose Counter

**SLT** - Trimline L-Shaped Heated  
Serving Counter

**ACR** - Air Curtain Refrigerators



# SCN SERIES - TRIMLINE ALL PURPOSE COUNTERS

## SLT4 SERIES - TRIMLINE L-SHAPED HEATED SERVING COUNTERS

### Product Information

#### SCN

- 20-gauge stainless steel exterior body
- Reinforced internally
- 14-gauge stainless steel top
- Standard on polyolefin casters

#### SLT

- 20-gauge stainless steel exterior body
- 16-gauge stainless steel top
- (4) 12 x 20 electrical individually controlled wells
- One main on/off switch
- 10' cord and plug
- 6" high flange feet
- One year parts and 90 day labor standard warranty. Additional warranties available, see below



SCN-68



SLT4

### Specifications and Prices

MODEL NUMBER	DIMENSIONS			AMPS	VOLTS	WATTS	NEMA PLUG	SHIP WEIGHT	FREIGHT CLASS	LIST PRICE
	L	D	H							
<b>SHELLESTEEL TRIMLINE ALL PURPOSE COUNTERS</b>										
SCN-48	48"	20.25"	37"	N/A	N/A	N/A	N/A	165	100	\$4,884
SCN-68	68"	20.25"	37"	N/A	N/A	N/A	N/A	175	125	\$5,774
<b>SHELLESTEEL TRIMLINE L-SHAPED HEATED SERVING COUNTERS</b>										
SLT4	68.62"	30.25"	36"	22.0	120/208-230	N/A	14-30P	300	125	\$11,628

### Accessories and Modifications

115-208V/15A outlet with 10A breaker* -----	\$933
Four individual drains, plumbed to common valve (SLT4 only)-----	\$1,664
Undershelf (48" SCN units only) -----	\$996
Undershelf (68" SCN units only) -----	\$1,510
Rack for one 12 x 20 pan (SLT4 only)-----	\$1,164
220V, 50/60 cycle, single phase electrical connection* -----	\$1,023

\* Inclusion of these options will alter the electrical specifications of unit.

TRAY MAKE UP

Additional Warranties	
Net Pricing	
One year parts and labor contract -----	\$279
Two year parts and labor contract-----	\$523

# ACR - AIR CURTAIN REFRIGERATORS



**ACR-26S**

## Product Information

- Cabinet to be 20-gauge stainless steel
- Interior cabinet constructed of 22-gauge stainless steel, cleaning radii, sealed joints, and seams
- Units insulated with foamed in place high density polyurethane (minimum 2.00")
- Fully insulated 20-gauge stainless steel door with magnetic catch and 270° open position
- Door locks standard
- Full width rubber ended rear push/pull handle
- (4) 4.00" diameter gray rubber casters (all locking)
- Designed for 18.00" x 26.00" trays
- Patented air current design keeps cold air in and hot air out
- Microprocessor solid state control with temperature, time, clean condenser alert and self diagnostics
- 9' cord and plug supplied
- Environmentally friendly R404A refrigerant
- One year parts and 90 day labor standard warranty. Additional warranties available, see below

MODEL NUMBER	DIMENSIONS			TRAY CAPACITY	CU. FT. CAPACITY		H.P.	AMP	VOLTS	NEMA PLUG	SHIP WEIGHT	FREIGHT CLASS	LIST PRICE
	L	D	H										
<b>FREE-STANDING TRAY MAKE UP REFRIGERATOR</b>													
With "air curtain" opening													
<b>ACR-26S</b>	26.50"	36.25"	79.25"	10	12.5	1/2	12.0	120	5-15P	592	110	<b>\$21,807</b>	

## Accessories and Modifications

Side and corner bumpers ----- \$581

### Additional Warranties

Net Pricing

One year parts and labor contract ----- \$279

Two year parts and labor contract ----- \$523

Five year compressor warranty 1/2 H.P. ----- \$139





## **DROP-INS**

**200/300** - Drop-In Freezers, Water Stations, and Ice Chests

**N8000/N8100** - Drop-In Cold Pans

**N8200** - Frost Tops

**8100EF** - LiquiTec® Refrigerated Cold Pans

**N8600** - Combination Hot/Cold Wells

**N8700** - Heated Food Wells

**N8800** - Single Tank Hot Food Wells

**N8000N** - Narrow Line Drop Ins

**DIS** - Drop-In Dish Dispensers

**CD, ND and SB** - Drop-In Cup, Napkin, Tray, and Bread Dispensers

**LT**- Drop-In Tray and Rack Dispensers

## **BUILT-INS**

**MFSC/MF** - Built-In Milk or Beverage Dispensers



## 200 SERIES - DROP-IN FREEZERS, WATER STATIONS, UNDERCOUNTER SINK AND FAUCETS

## 300 SERIES - ICE CHEST AND GLASS FILLER

### Product Information

#### N225-N227 SERIES ONLY

- 18-gauge stainless steel top construction
- 26.81" overall height
- Die stamped top opening with raised edge
- High-density polyurethane foam throughout unit
- Freezer tank is constructed of 2BF with large cleanout radii
- Mechanically cooled 0° to 5° tank storage temperatures meeting NSF and UL requirements
- Folding removable cover with black rubber external handle for easy grip
- 9' cord and plug
- Durable 16-gauge compressor cage
- Environmentally friendly HFC-404A refrigerant
- Optional 220v-50 cycle
- Remote units available
- Non-marring press fit gasket
- Stainless steel louver sent loose for field installation
- Suitable for ice cream storage.

#### 240 SERIES ONLY

- 20-gauge stainless steel top and body
- One piece stainless lift off cover with handle
- Stainless steel interior liner with coved corners
- 1" diameter drain plumbed out the bottom
- High-density polyurethane foam throughout unit

#### 203/305 SERIES ONLY

- 20-gauge stainless steel top with raised die stamped opening
- Galvanized exterior body
- One piece stainless lift off cover with handle
- 1" diameter drain plumbed out the bottom
- High-density polyurethane foam throughout unit
- 305: ABS plastic interior line with coved corners
- 203: stainless steel interior liner with coved corners

#### 204/248 SERIES ONLY

- 18-gauge stainless steel top with raised die stamped opening
- One piece stainless lift off cover with handle
- ABS plastic interior liner with coved corners
- 1" diameter drain plumbed out the bottom
- High-density polyurethane foam throughout unit
- Exterior tank is made of galvanized steel
- Glass filler is 9.5" high, over a die stamped drain opening fitted with chrome plated wire strainer

#### 307 SERIES ONLY

- Glass filler is 9.5" high, over a die stamped drain opening fitted with chrome plated wire strainer

#### ALL UNITS:

- One year parts and 90 day labor standard warranty. Additional warranties available, see below



227



203



204



307



250



240

### Specifications and Prices

MODEL NUMBER	OVERALL			CUTOUT SIZE	CABINET CAPACITY	H.P.	AMP	VOLTS	NEMA PLUG	SHIP WEIGHT	FREIGHT CLASS	LIST PRICE
	L	D	H									

#### DROP-IN FREEZERS

N225	16.56"	27.87"	26.75"	25.75" x 14.62"	6 gal.	1/5	5.3	115	5-15P	115	110	\$5,070
N227	30"	27.87"	26.75"	25.75" x 28"	12 gal.	1/5	5.3	115	5-15P	191	85	\$6,639

#### DROP-IN FREEZERS WITH ACRYLIC LID

225L	16.56"	27.87"	26.75"	25.75" x 14.62"	6 gal.	1/5	5.3	115	5-15P	115	110	\$5,208
227L	30"	27.87"	26.75"	25.75" x 28"	12 gal.	1/5	5.3	115	5-15P	191	85	\$7,338

MODEL NUMBER	DESCRIPTION	OVERALL			CUTOUT SIZE	ICE CAPACITY	SHIP WEIGHT	FREIGHT CLASS	PRICE
		L	D	H					

#### DROP-IN WATER STATIONS AND ICE STORAGE

203	ice chest	20.25"	20.25"	23.25"	19.25" x 19.25"	90 lbs.	52	85	\$1,901
204	water & ice station	24"	21"	22.6"	21" x 17.75"	45 lbs.	47.5	85	\$1,938
204P	water & ice station	24"	21"	26.35"	21" x 17.75"	45 lbs.	47.5	85	\$2,308
240	ice chest with cover	21"	17.5"	17"	—	75 lbs.	36	85	\$2,317
248	water & ice station	31"	15"	22.6"	28" x 12.5"	45 lbs.	28	85	\$2,247
305	ice chest with cover	21.25"	15.25"	13"	17.75" x 12.5"	45 lbs.	18	85	\$1,142
307	glass filler	12"	12"	9.5"	—	—	7	85	\$658

#### UNDERCOUNTER SINKS, WATER STATIONS AND ICE STORAGE

242	undercounter sink & faucet	18"	13.5"	12.75"	16" x 12.5"	—	20	85	\$1,733
250	undercounter sink, ice chest and water station	46"	14.12"	22.75"	45" x 13"	45 lbs.	81	85	\$3,297

Drop-in accessories and modifications can be found on page 149.

#### Additional Warranties

Net Pricing

One year parts and labor contract ----- \$279

Two year parts and labor contract ----- \$523

Five year compressor warranty 1/5 H.P. ----- \$108





# N8000 SERIES - ICE COOLED COLD PANS N8100B SERIES - MECHANICALLY COOLED COLD PANS N8000N SERIES - NARROW ICE COOLED COLD PANS N8100N SERIES - NARROW MECHANICALLY COOLED COLD PANS

## Product Information

### N8000 SERIES ONLY

- 20-gauge stainless steel top construction
- 2 BF stainless steel interior liner
- Sectional removable perforated bottoms
- Adapter bars are provided standard for 12" x 20" openings
- Standard 1" plastic drain
- High density polyurethane foam insulation throughout unit
- Galvanized exterior body
- Custom sizes available
- Non-marring press fit top gasket is supplied standard
- NSF-2 certified
- One year parts and 90 day labor standard warranty. Additional warranties available, see below

- Adapter bars are provided standard for 12" x 20" openings
- Standard 1" plastic drain
- High density polyurethane foam insulation throughout unit
- Galvanized exterior body
- Non-marring press fit top gasket is supplied standard
- NSF-7 certified
- Condensing unit is suspended below on a 16-gauge galvanized frame
- HFC-134A refrigerant
- 8' cord is standard
- Stainless steel louver is provided for field installation
- Custom sizes available
- One year parts and 90 day labor standard warranty. Additional warranties available, see below



**N8056**



**N8156-B**

### N8100B/8100NB SERIES ONLY

- 20-gauge stainless steel top construction
- 2 BF stainless steel interior liner wrapped and spot clipped with refrigeration lines; thermal transfer compound is applied for superior cooling
- V-stamped pan rest recessed 2"
- Mechanically cooled system

## Specifications and Prices

MODEL NUMBER	OVERALL			12 X 20	CUTOUT	H.P.	AMP	VOLTS	NEMA PLUG	SHIP WEIGHT	FREIGHT CLASS	LIST PRICE
	L	D	H	PANS HELD	SIZE							
<b>ICE COOLED COLD PANS</b> <i>8" pan depth Adapter bars and perforated bottoms standard</i>												
<b>N8018</b>	18"	26"	10.75"	1	17" X 25"	N/A	N/A	N/A	N/A	38	85	<b>\$1,762</b>
<b>N8030</b>	30.75"	26"	10.75"	2	29.75" X 25"	N/A	N/A	N/A	N/A	84	85	<b>\$1,948</b>
<b>N8043</b>	43.5"	26"	10.75"	3	42.50" X 25"	N/A	N/A	N/A	N/A	110	85	<b>\$2,240</b>
<b>N8056</b>	56.25"	26"	10.75"	4	55.25" X 25"	N/A	N/A	N/A	N/A	139	85	<b>\$2,616</b>
<b>N8069</b>	69"	26"	10.75"	5	68" X 25"	N/A	N/A	N/A	N/A	160	85	<b>\$2,922</b>
<b>N8081</b>	81.75"	26"	10.75"	6	80.75" X 25"	N/A	N/A	N/A	N/A	197	85	<b>\$3,447</b>
<b>MECHANICALLY COOLED PANS</b> <i>8" pan depth Adapter bars standard</i>												
<b>N8118B</b>	18"	26"	21.87"	1	17" X 25"	1/5	4.0	115	5-15P	100	85	<b>\$4,902</b>
<b>N8130B</b>	30.75"	26"	21.87"	2	29.75" X 25"	1/5	4.0	115	5-15P	140	85	<b>\$5,242</b>
<b>N8143B</b>	43.5"	26"	21.87"	3	42.50" x 25"	1/5	4.0	115	5-15P	173	85	<b>\$5,700</b>
<b>N8156B</b>	56.25"	26"	21.87"	4	55.25" x 25"	1/4	7.0	115	5-15P	205	85	<b>\$6,125</b>
<b>N8169B</b>	69"	26"	21.87"	5	68" x 25"	1/4	7.0	115	5-15P	225	85	<b>\$6,660</b>
<b>N8181B</b>	81.75"	26"	21.87"	6	80.75" x 25"	1/3	8.0	115	5-15P	258	85	<b>\$7,183</b>

### NARROW LINE DROP-INS

#### Ice cooled cold pans

<b>N8046N</b>	46.75"	18"	10.75"	2	45.75" x 17"	N/A	N/A	N/A	N/A	100	85	<b>\$1,948</b>
<b>N8068N</b>	67.5"	18"	10.75"	3	66.5" x 17"	N/A	N/A	N/A	N/A	120	85	<b>\$2,240</b>

#### Mechanically cooled cold pans

<b>N8146NB</b>	46.75"	18"	21.81"	2	45.75" x 17"	1/5	4.0	115	N/A	5-15P	175	85	<b>\$5,242</b>
<b>N8168NB</b>	67.50"	18"	21.81"	3	66.5" x 17"	1/5	4.0	115	N/A	5-15P	240	85	<b>\$5,700</b>

Drop-in accessories and modifications can be found on page 149.

### Additional Warranties

	Net Pricing
One year parts and labor contract -----	\$279
Two year parts and labor contract -----	\$523
Five year compressor warranty	
1/5 H.P. -----	\$108
1/4 H.P. -----	\$108
1/3 H.P. -----	\$128

# 8100-EF SERIES - LIQUITEC® REFRIGERATED COLD PANS N8100-FA SERIES - FORCED AIR COLD PANS



**8145-EF**



**N8131-FA**

## Product Information

### 8100-EF SERIES ONLY

- 18-gauge stainless steel top construction
- 2BF stainless steel liner wrapped and spot clipped with refrigeration lines; thermal transfer compound is applied for superior cooling
- Mechanically cooled system
- Flush mounted die stamped drawn 12" x 20" individual 20-gauge wells
- Wells to be depressed slightly into the top to hold condensation
- Standard 1/2" stainless steel drain
- High density polyurethane foam insulation throughout unit
- Galvanized exterior body
- Thermostatic temperature with OFF position and expansion valve standard
- Non-marring press fit top gasket is supplied standard
- NSF7 certified
- Condensing unit is suspended below on a 16-gauge galvanized frame
- Environmentally friendly HFC-404A refrigerant
- 8' cord is standard
- Stainless steel louver is provided standard for field installation
- "EFN" slimline models run 12" x 20" well left to right instead of front to back
- One year parts and 90 day labor standard warranty. Additional warranties available.

### N8100-FA SERIES ONLY

- 20-gauge stainless steel top construction
- 2BF stainless steel liner kinked to drain
- Stainless steel pan holds product flush with top
- Air curtain system with evaporator coil and fan package located below false bottom. Air movement over product maintains NSF7 requirements
- Standard 1" plastic drain
- High density polyurethane foam insulation throughout unit
- Galvanized exterior body
- On/off switch with pressure control, and expansion valve standard
- Non-marring press fit top gasket is supplied standard
- NSF7 certified
- Condensing unit is suspended below on a 16-gauge galvanized frame
- Environmentally friendly HFC-404A refrigerant
- 8' cord is standard
- Stainless steel louver is provided standard for field installation
- Air curtain assembly is removable without tools for easy cleaning

## Specifications and Prices

MODEL NUMBER	OVERALL			CUTOUT SIZE	12 x 20 PANS HELD	AMPS	H.P.	VOLTS	NEMA PLUG	SHIP WEIGHT	FREIGHT CLASS	LIST PRICE
	L	D	H									
<b>LiquiTec® EUTECTIC FLUID REFRIGERATED COLD PANS</b>												
<b>8118-EF</b>	18.20"	26"	23.25"	17" x 25"	1	7.5	1/4	115	5-15P	169	85	<b>\$6,525</b>
<b>8132-EF</b>	31.76"	26"	23.25"	30.75" x 25"	2	7.5	1/4	115	5-15P	215	85	<b>\$6,976</b>
<b>8145-EF</b>	45.32"	26"	23.25"	44.25" x 25"	3	7.5	1/4	115	5-15P	265	85	<b>\$7,587</b>
<b>8159-EF</b>	58.88"	26"	23.25"	57.87" x 25"	4	7.5	1/4	115	5-15P	285	85	<b>\$8,148</b>
<b>8172-EF</b>	72.44"	26"	23.25"	71.5" x 25"	5	7.5	1/4	115	5-15P	295	85	<b>\$8,863</b>
<b>8186-EF</b>	86"	26"	23.25"	85.0" x 25"	6	7.5	1/4	115	5-15P	394	85	<b>\$9,573</b>

MODEL NUMBER	OVERALL			CUTOUT SIZE	12 x 20 PANS HELD	AMPS	H.P.	VOLTS	NEMA PLUG	SHIP WEIGHT	FREIGHT CLASS	LIST PRICE
	L	D	H									
<b>LiquiTec® SLIM LINE EUTECTIC FLUID REFRIGERATED COLD PANS</b>												
<b>8148-EFN</b>	47.66"	18"	23.25"	46.88" x 17.25"	2	7.5	1/4	115	5-15P	235	85	<b>\$7,664</b>
<b>8169-EFN</b>	69.22"	18"	23.25"	68.50" x 17.25"	3	7.5	1/4	115	5-15P	285	85	<b>\$8,939</b>
<b>8191-EFN</b>	90.78"	18"	23.25"	90" x 17.25"	4	7.5	1/4	115	5-15P	295	85	<b>\$9,648</b>

MODEL NUMBER	OVERALL			12 x 20 PANS HELD	CUTOUT SIZE	H.P.	AMP	VOLTS	NEMA PLUG	SHIP WEIGHT	FREIGHT CLASS	LIST PRICE
	L	D	H									
<b>FORCED AIR DROP-IN MECHANICALLY COOLED PANS</b>												
<b>N8131-FA</b>	31.25"	26.67"	28.62"	2	30.25" x 25.50"	1/4	7.8	115	5-15P	220	85	<b>\$7,522</b>
<b>N8144-FA</b>	44"	26.67"	28.62"	3	43.00" x 25.50"	1/2	9.2	115	5-15P	267	85	<b>\$8,151</b>
<b>N8157-FA</b>	56.75"	26.67"	28.62"	4	55.75" x 25.50"	1/2	9.2	115	5-15P	310	85	<b>\$8,567</b>
<b>N8169-FA</b>	69.5"	26.67"	28.62"	5	68.50" x 25.50"	3/4	14.8	115	5-20P	365	85	<b>\$8,985</b>
<b>N8182-FA</b>	82.25"	26.67"	28.62"	6	81.25" x 25.50"	3/4	14.8	115	5-20P	406	85	<b>\$9,617</b>

Drop-in accessories and modifications can be found on page 149.

Additional Warranties	
	Net Pricing
One year parts and labor contract	----- \$279
Two year parts and labor contract	----- \$523
Five year compressor warranty	
1/4 H.P.	----- \$108
1/2 H.P.	----- \$139
3/4 H.P.	----- \$145



# N8200 SERIES - FROST TOPS

## N8200G SERIES - GRANITE COLD SLAB

### Product Information

#### N8200 SERIES ONLY

- 18-gauge stainless steel top construction
- Top has integral drain trough and 2.00" overhang around perimeter
- Top is elevated 1.68" above counter surface and angles approximately 45° into the trough
- The bottom interior of the top is serpentine wrapped, taped, then foamed with high density polyurethane foam insulation.
- Exterior body is galvanized steel
- Condensing unit is suspended below on a 16-gauge galvanized frame
- Environmentally friendly HFC-404A refrigerant
- 8' cord is standard
- Stainless steel louver is provided standard for field installation
- Custom sizes available
- Standard 1/2" stainless steel tubing drain
- Unit is equipped with an on/off switch
- Non-marring press fit top gasket is supplied standard
- NSF certified

#### N8200G SERIES ONLY

- 14-gauge stainless steel top with "Absolute Black" granite
- Thermal transfer compound installed between stainless steel and granite top
- Top has integral drain trough 1.5" deep around perimeter
- Top is elevated 1.25" above counter surface
- Unit foamed with high density polyurethane insulation
- Exterior body is galvanized steel
- Condensing unit is suspended below on a 16-gauge galvanized steel frame
- Environmentally friendly HFC-404A refrigerant
- 8' cord is standard
- Stainless steel louver is provided standard for field installation
- Standard 3/4" stainless steel drain
- Unit is equipped with an ON/OFF switch
- NSF certified

#### ALL UNITS

- One year parts and 90 day labor standard warranty. Additional warranties available.



N8259



N8245G

### Specifications and Prices

MODEL NUMBER	L	OVERALL D	H	12 x 20 PANS HELD	CUTOUT SIZE	H.P.	AMP	VOLTS	NEMA PLUG	SHIP WEIGHT	FREIGHT CLASS	LIST PRICE
<b>FROST TOPS</b>												
N8231	31.75"	26"	15.75"	—	30.75" x 25"	1/4	7.5	115	5-15P	142	85	\$5,429
N8245	45.63"	26"	15.75"	—	44.63" x 25"	1/4	7.5	115	5-15P	168	85	\$5,642
N8259	59.5"	26"	15.75"	—	58.50" x 25"	1/4	7.5	115	5-15P	193	85	\$6,119
N8273	73.38"	26"	15.75"	—	72.38" x 25"	1/4	8.0	115	5-15P	209	85	\$6,545
N8287	87.25"	26"	15.75"	—	86.25" x 25"	1/3	8.0	115	5-15P	239	85	\$7,210
<b>GRANITE COLD SLAB</b>												
N8231G	31.75"	25.87"	19"	—	30.75" x 25"	1/4	7.5	115	5-15P	219	85	\$7,527
N8245G	45.63"	25.87"	19"	—	44.63" x 25"	1/4	7.5	115	5-15P	284	85	\$8,559
N8259G	59.5"	25.87"	19"	—	58.50" x 25"	1/3	8.0	115	5-15P	338	85	\$10,172
N8273G	73.38"	25.87"	19"	—	72.38" x 25"	1/2	9.0	115	5-15P	425	85	\$11,128

Drop-in accessories and modifications can be found on page 149.

Additional Warranties	
Net Pricing	
One year parts and labor contract -----	\$279
Two year parts and labor contract -----	\$523
Five year compressor warranty	
1/4 H.P. -----	\$108
1/3 H.P. -----	\$128
1/2 H.P. -----	\$139

# N8600 SERIES - COMBINATION HOT/COLD WELLS

## N8800 SERIES - SINGLE TANK HOT FOOD WELLS



**N8643**



**N8845**

### Product Information

#### N8600 SERIES ONLY

- Dual temp hot or cold operation
- 20-gauge stainless steel top construction
- Single "wet only" well with immersion heater(s) and 1" stainless steel drain
- Adapter bars standard to accommodate 12"x20" pans
- Remote control panel with 3-way Hot/Off/Cold power switch and thermostatic control for hot operation
- Thermostat for cold operation located by condensing unit
- Non-marring press fit top gasket is supplied standard
- High density polyurethane foam insulation throughout unit
- Stainless steel liner wrapped with spot clipped refrigeration lines; thermal transfer compound applied for superior cooling
- Galvanized exterior body
- Condensing unit suspended below on a 16-gauge galvanized frame

- HFC404A refrigeration system with thermostatic expansion valve
- Unit must be hard wired in field
- Stainless steel louver is provided standard for field installation

#### N8800 SERIES ONLY

- Adapter bars provided standard to accommodate 12" x 20" pans
- Single wet only well 8" deep made of 316 series stainless kinked to stainless 1" drain
- Single thermostatic temperature control wired to (1) main control panel with 2' of conduit and wire. Field install control panel at locations

#### ALL UNITS

- One year parts and 90 day labor standard warranty. Additional warranties available, see below

### Specifications and Prices

MODEL NUMBER	OVERALL		12 x 20	CUTOUT	H.P.	AMP	VOLTS	WATTS	NEMA PLUG	SHIP WEIGHT	FREIGHT CLASS	LIST PRICE	
	L	D	PANS HELD	SIZE									
<b>COMBINATION HOT/COLD FOOD WELLS</b> <small>8" pan depth Pilot indicator lights included</small>													
N8630	30.75"	26"	25.75"	2	29.75" x 25"	1/4	24.0	120	3000	N/A	164	85	\$9,678
N8643	43.5"	26"	25.75"	3	42.50" x 25"	1/4	21.0	120/240	5000	N/A	198	85	\$10,176
N8656	56.25"	26"	25.75"	4	55.25" x 25"	1/4	21.0	120/240	5000	N/A	233	85	\$10,818
N8669	69"	26"	25.75"	5	68" x 25"	1/4	42.0	120/240	10000	N/A	266	85	\$11,671
N8681	81.75"	26"	25.75"	6	80.75" x 25"	1/3	42.0	120/240	10000	N/A	301	85	\$13,014

MODEL NUMBER	OVERALL		12 x 20	CUTOUT	H.P.	AMP	VOLTS	WATTS	NEMA PLUG	SHIP WEIGHT	FREIGHT CLASS	LIST PRICE	
	L	D	PANS HELD	SIZE									
<b>SINGLE TANK HOT FOOD WELLS</b> <small>6" pan depth Pilot light included</small>													
N8831	31.75"	26"	11"	2	30.75" x 25"	N/A	17.0	120	2000	N/A	100	85	\$2,604
N8845	45.63"	26"	11"	3	44.63" x 25"	N/A	15/16	208-230	3000/3600	N/A	136	85	\$3,056
N8859	59.5"	26"	11"	4	58.5" x 25"	N/A	20/22	208-230	4000/4800	N/A	158	85	\$3,460
N8873	73.38"	26"	11"	5	72.38" x 25"	N/A	24/27	208-230	5000/6000	N/A	195	85	\$3,990
N8887	87.25"	26"	11"	6	86.25" x 25"	N/A	29/32	208-230	6000/7200	N/A	224	85	\$4,472

Drop-in accessories and modifications can be found on page 149.

#### Additional Warranties

Net Pricing

One year parts and labor contract ----- \$279

Two year parts and labor contract ----- \$523

Five year compressor warranty  
1/4 H.P. ----- \$108  
1/3 H.P. ----- \$128



# N8700 SERIES - HEATED FOOD WELLS

## N8700N SERIES - INDIVIDUALLY HEATED NARROW FOOD WELLS

### Product Information

#### N8700ND SERIES ONLY

- Top is constructed of 18-gauge stainless steel
- Flush mounted die stamped drawn 12" x 20" individual 20-gauge wells
- Wells to be depressed slightly into the top to hold in condensation
- Standard 1/2" stainless steel drain(s)
- Non-marring press fit top gasket is supplied standard
- Must be hard wired in the field
- Wet and dry operation
- 11.87" x 19.87" single hot food wells are manifolded together standard to one main gate valve
- Unit shall be insulated on all sides with 1" of fiberglass and bottom to have 2" of fiberfrax blanket insulation
- Individual infinite temperature controls standard wired to one main control panel with 4' of conduit and wire. Field install control panel at location
- Galvanized exterior body

- Wells to be depressed slightly into the top to hold in condensation
- Standard 1/2" stainless steel drain(s)
- Non-marring press fit top gasket is supplied standard
- Must be hard wired in the field
- Wet and dry operation
- 11.87" x 19.87" single hot food wells are manifolded together standard to one main gate valve
- Unit shall be insulated on all sides with 1" of fiberglass and bottom to have 2" of fiberfrax blanket insulation
- Individual infinite temperature controls standard wired to one main control panel with 4' of conduit and wire. Field install control panel at location
- Galvanized exterior body

#### ALL UNITS

- One year parts and 90 day labor standard warranty. Additional warranties available, see below



N8787-D

#### N8700N SERIES ONLY

- Top is constructed of 18-gauge stainless steel
- Flush mounted die stamped drawn 12" x 20" individual 20-gauge wells

### Specifications and Prices

MODEL NUMBER	OVERALL			12 x 20	CUTOUT	H.P.	AMP	VOLTS	WATTS	NEMA PLUG	SHIP WEIGHT	FREIGHT CLASS	LIST PRICE
	L	D	H	PANS HELD	SIZE								
<b>INDIVIDUALLY HEATED FOOD WELLS</b> (with drains and manifold 6" pan depth) <i>Pilot lights included 208-230 volt system</i>													
N8717-D	17.88"	26"	9.5"	1	16.88" x 25"	—	8.3	120	1000	N/A	41	85	\$1,918
N8731-D	31.75"	26"	9.5"	2	30.75" x 25"	—	16.6	120	2000	N/A	99	85	\$3,015
N8745-D	45.63"	26"	9.5"	3	44.62" x 25"	—	15.0/16.0	208/230	3000/4000	N/A	134	85	\$4,270
N8759-D	59.5"	26"	9.5"	4	58.5" x 25"	—	20.0/22.0	208/230	4000/4800	N/A	166	85	\$5,554
N8773-D	73.38"	26"	9.5"	5	72.37" x 25"	—	24.0/27.0	208/230	5000/6000	N/A	186	85	\$6,830
N8787-D	87.25"	26"	9.5"	6	86.25" x 25"	—	29.0/32.0	208/230	6000/7200	N/A	236	85	\$8,144
<b>INDIVIDUALLY HEATED NARROW FOOD WELLS WITH DRAINS</b>													
N8746ND	45.61"	15.87"	9.5"	2	44.62" x 15"	N/A	17.0	120	2000	N/A	100	85	\$3,015
N8768ND	67.48"	15.87"	9.5"	3	66.50" x 15"	N/A	15/16	208-230	3000/3600	N/A	130	85	\$4,270
<b>INDIVIDUALLY HEATED NARROW FOOD WELLS WITHOUT DRAINS</b>													
N8746N	45.61"	15.87"	9.5"	2	44.62" x 15"	N/A	17.0	120	2000	N/A	100	85	\$2,873
N8768N	67.48"	15.87"	9.5"	3	66.50" x 15"	N/A	15/16	208-230	3000/3600	N/A	130	85	\$4,066

N8700D - 14" overall height including drain connection.

Drop-in accessories and modifications can be found on page 149.

#### Additional Warranties

Net Pricing

One year parts and labor contract ----- \$279

Two year parts and labor contract ----- \$523

# N8000-R: DROP-IN RADIAL ICE COOLED COLD PAN

# N8100-BR: DROP-IN RADIAL MECHANICALLY COOLED COLD PAN

# N8700-R: DROP-IN RADIAL HEATED ELECTRIC FOOD WELLS

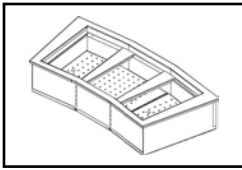

N8059-R

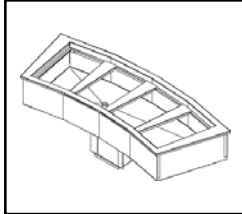

N8176-BR

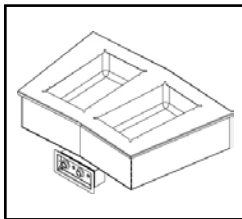

N8744-R

## Product Information

### N8000-R UNITS ONLY

- NSF certified
- A stainless steel holding clip adjusts for pans
- Push-in perimeter gasket
- 1" drain standard
- High density foamed in place environmentally friendly, Kyoto Protocol Compliant, Non ODP (Ozone Depletion Potential), Non GWP (Global Warming Potential) polyurethane Keeps energy costs low
- Removable perforated, false bottom
- One year parts and labor standard warranty

### N8100-BR UNITS ONLY

- NSF-7 certified performance
- A stainless steel holding clip adjusts for pans
- High density foamed in place environmentally friendly, Kyoto Protocol Compliant, Non ODP (Ozone Depletion Potential), Non GWP (Global Warming Potential) polyurethane Keeps energy costs low
- Push-in perimeter gasket
- Stainless steel louver provided
- Environmentally friendly HFC-134A refrigerant

- 1" drain standard
- Thermostat for temperature control
- One year parts and labor standard warranty

### N8700-R UNITS ONLY

- Top is constructed of 18-gauge stainless steel
- Flush mounted die stamped drawn 12"x20" individual 20-gauge wells
- Wells depressed slightly into the top to hold condensation
- Standard 1/2" stainless steel drain(s)
- Non-marring press fit top gasket
- Must be hard wired in the field
- Wet and dry operation
- 11.87"x19.87" single hot food wells are manifolded together standard to one main gate valve
- Unit shall be insulated on all sides with 1" of fiberglass and bottom to have 2" of fiberfrax blanket insulation
- Individual infinite temperature controls standard wired to one main control panel with 4' of conduit and wire. Field install control panel at location
- Galvanized exterior body
- One year parts and labor standard warranty

## Specifications and Prices

MODEL NUMBER	OVERALL L	OVERALL D	OVERALL H	12"x20" PAN CAP.	SHIP WEIGHT	FREIGHT CLASS	LIST PRICE
<b>Ice cooled radial drop-in</b>							
N8044-R	40.48"	26.05"	10.77"	2	100 lbs.	85	\$2,041
N8059-R	57.22"	26.05"	10.77"	3	118 lbs.	85	\$2,345
N8076-R	73.68"	26.05"	10.77"	4	145 lbs.	85	\$2,739
N8094-R	89.89"	26.05"	10.77"	5	164 lbs.	85	\$3,061

MODEL NUMBER	OVERALL L	OVERALL D	OVERALL H	12"x20" PAN CAP.	H.P.	AMP	BTU LOAD	VOLTS/HERTZ/ PHASE	NEMA PLUG	SHIP WEIGHT	FREIGHT CLASS	LIST PRICE
<b>Mechanically cooled radial drop-in</b>												
N8144-BR	40.48"	26.05"	10.77"	2	1/5	4.0	379	115/60/1	5-15P	161 lbs.	85	\$5,493
N8159-BR	57.22"	26.05"	10.77"	3	1/5	4.0	569	115/60/1	5-15P	184 lbs.	85	\$5,971
N8176-BR	73.68"	26.05"	10.77"	4	1/4	7.0	758	115/60/1	5-15P	233 lbs.	85	\$6,416
N8194-BR	89.89"	26.05"	10.77"	5	1/4	7.0	948	115/60/1	5-15P	243 lbs.	85	\$6,976

MODEL NUMBER	OVERALL L	OVERALL D	OVERALL H	12"x20" PAN CAP.	AMP	WATTS	VOLTS/HERTZ/ PHASE	SHIP WEIGHT	FREIGHT CLASS	LIST PRICE
<b>Heated radial drop ins</b>										
N8744-R	40.48"	26.05"	9.08"	2	16.6	2000	120/60/1	99 lbs.	85	\$3,252
N8759-R	57.22"	26.05"	9.08"	3	15.0/16.0	3000/4000	208-230/60/1	134 lbs.	85	\$4,606
N8776-R	73.68"	26.05"	9.08"	4	20.0/22.0	4000/4800	208-230/60/1	166 lbs.	85	\$5,989
N8794-R	89.80"	26.05"	9.08"	5	24.0/27.0	5000/6000	208-230/60/1	186 lbs.	85	\$7,368

Drop-in accessories and modifications can be found on page 149.

### Additional Warranties

Net Pricing

One year parts and labor contract ---\$279

Two year parts and labor contract --\$523

Five year compressor warranty

1/5 H.P. -----\$108

1/4 H.P. -----\$108





# DIS - DROP-IN DISH DISPENSERS

## Product Information

### DIS SERIES ONLY

- Top flange and bottom brace to be 18-gauge stainless steel
- Vertical side channels to be 22-gauge stainless steel
- Flange, channels and bottom to be integrally welded
- Spring supports to be 14-gauge stainless steel
- Carrier head made of welded rods with a removable 18-gauge top plate
- Self-leveling mechanism, field adjustable by adding or removing springs
- High impact plastic guide posts mounted to flange
- One year parts and 90 day labor standard warranty. Additional warranties available, see below

### DIS-ET/QT SERIES ONLY

- 4' cord and plug
- Convection heating module and fan motor
- Air intake shall be filtered
- On/off switch and adjustable thermostat
- Outer 22-gauge stainless steel jacket
- QT- Shall have a stainless steel cover
- ET- Maintains temperatures between 120-140°F (49-60°C)
- QT- Maintains temperatures between 150-170°F (66-77°C)
- One year parts and 90 day labor standard warranty. Additional warranties available, see below



**DIS-1013ET**  
with optional adjustment rods

## Specifications and Prices

MODEL NUMBER	FLANGE DIAMETER	HEIGHT	CUTOUT DIAMETER	DISH DIAMETER	AMPS	VOLTS	NEMA PLUG	SHIP WATT	SHIP WEIGHT	FREIGHT CLASS	LIST PRICE
<b>DROP-IN DISH DISPENSERS</b>											
<b>Unheated</b>											
DIS-500	8.37"	28"	7.75"	3"-5"	N/A	N/A	N/A	N/A	7	100	\$709
DIS-575	9.12"	28"	8.5"	5"-5.75"	N/A	N/A	N/A	N/A	8	100	\$816
DIS-650	9.87"	28"	9.25"	5.75"-6.5"	N/A	N/A	N/A	N/A	9	100	\$861
DIS-725	10.62"	28"	10"	6.5"-7.25"	N/A	N/A	N/A	N/A	10	100	\$904
DIS-813	11.5"	28"	10.87"	7.25"-8.12"	N/A	N/A	N/A	N/A	11	100	\$948
DIS-913	12.5"	28"	11.87"	8.13"-9.12"	N/A	N/A	N/A	N/A	12	100	\$1,020
DIS-1013	13.5"	28"	12.87"	9.13"-10.12"	N/A	N/A	N/A	N/A	13	100	\$1,079
DIS-1200	15.38"	28"	14.75"	10.13"-12"	N/A	N/A	N/A	N/A	15	100	\$1,301
DIS-1450	17.88"	28"	17.25"	12"-14.5"	N/A	N/A	N/A	N/A	17	100	\$1,446
<b>Even Temp heated dispensers</b>											
DIS-500-ET	8.37"	28"	7.75"	3"-5"	5.5	120	5-15P	400	17	125	\$1,402
DIS-575-ET	9.12"	28"	8.5"	5"-5.75"	5.5	120	5-15P	400	17	125	\$1,489
DIS-650-ET	9.87"	28"	9.25"	5.75"-6.5"	5.5	120	5-15P	400	19	125	\$1,561
DIS-725-ET	10.62"	28"	10"	6.5"-7.25"	5.5	120	5-15P	400	21	125	\$1,646
DIS-813-ET	11.5"	28"	10.87"	7.25"-8.12"	5.5	120	5-15P	700	24	125	\$1,759
DIS-913-ET	12.5"	28"	11.87"	8.12"-9.12"	5.5	120	5-15P	700	25	125	\$1,841
DIS-1013-ET	13.5"	28"	12.87"	9.12"-10.12"	5.5	120	5-15P	700	27	125	\$1,910
DIS-1200-ET	15.37"	28"	14.75"	10.12"-12"	5.5	120	5-15P	700	32	125	\$2,154
DIS-1450-ET	17.87"	28"	17.25"	12"-14.5"	5.5	120	5-15P	700	37	125	\$2,308
<b>Quick Temp heated dispensers</b>											
DIS-813-QT	11.5"	28"	10.87"	7.25"-8.12"	5.5	120	5-15P	700	30	125	\$1,938
DIS-913-QT	12.5"	28"	11.87"	8.12"-9.12"	5.5	120	5-15P	700	32	125	\$2,193
DIS-1013-QT	13.5"	28"	12.87"	9.12"-10.12"	5.5	120	5-15P	700	34	125	\$2,298
DIS-1200-QT	15.37"	28"	14.75"	10.12"-12"	5.5	120	5-15P	700	37	125	\$2,505
DIS-1450-QT	17.87"	28"	17.25"	12"-14.5"	5.5	120	5-15P	700	41	125	\$2,553

Drop-in accessories and modifications can be found on page 149.



**DIS-650**

### Additional Warranties

Net Pricing

One year parts and labor contract ----- \$279

Two year parts and labor contract----- \$523



# CD SERIES - CUP DISPENSERS SB SERIES - BREAD DISPENSERS ND SERIES - NAPKIN DISPENSERS



## Product Information

### CD SERIES ONLY

- Dispenser tube is constructed of stainless steel with an 18-gauge support flange
- Elevating mechanism consists of stainless steel spring and three equally spaced stainless steel friction strips fastened to a stainless steel collar
- Two compression springs are provided; one for paper cups, and one for foam cups
- Dispenser capacities will vary depending on the style of cup

### SB SERIES ONLY

- Support flange and dispenser tube to be 18-gauge stainless steel
- Cover to be 16-gauge stainless steel
- Bread elevating mechanism consists of a calibrated stainless steel spring, which supports the adjustable carrier
- Removable mechanism
- Raising or lowering a self-locking disc contained within the carrier head accomplishes stacking height adjustment

### ND SERIES ONLY

- Top flange to be 18-gauge stainless steel
- Dispenser bottom to be 22-gauge stainless steel
- Dispenser body shall have four 22-gauge vertical angle guides integrally welded to the top flange and bottom
- Carrier head to be 22-gauge stainless steel
- Two extension springs support the carrier head
- Napkin cover to be 20-gauge stainless steel and snaps onto flange
- All models hold up to 500 paper napkins at an 18.00" stack height, capacity will vary
- Special heights available

### ALL UNITS

- One year parts and 90 day labor standard warranty. Additional warranties available, see below

## Specifications and Prices

MODEL NUMBER	FLANGE DIAMETER	HEIGHT	CUTOUT DIAMETER	DISH DIAMETER	SHIP WEIGHT	FREIGHT CLASS	LIST PRICE
<b>DISPOSABLE CUP DISPENSERS</b>							
GD	7.38"	24.5"	5.12"	2.5"-4.63"	N/A	100	\$463

<b>BREAD DISPENSERS</b>							
SB-1	6.63"	6.63"	28"	5.87" x 5.87"	15	100	\$1,671

MODEL NUMBER	L	D	H	CUTOUT DIMENSION	NAPKIN DIMENSIONS	SHIP WEIGHT	FREIGHT CLASS	LIST PRICE
<b>NAPKIN DISPENSERS</b>								
ND-45	7.62"	6"	24"	7" x 5.62"	4" x 5.37"	12	100	\$861
ND-47	9.37"	6.25"	24"	8.75" x 5.87"	4.25" x 7.12"	12	100	\$861
* ND-48	10.25"	6.25"	24"	9.62" x 6.12"	4.5" x 8"	16	100	\$904
* ND-57	9.25"	7.12"	24"	8.62" x 6.75"	5.12" x 7"	16	100	\$904
ND-59	11"	6.75"	24"	10.37" x 6.37"	4.75" x 8.75"	12	100	\$861
ND-67	9.37"	8.17"	24"	8.75" x 8.5"	6.87" x 7.12"	12	100	\$861

Shorten dispenser tubes to special length ----- add 10%

\* Denotes items available for quick shipment

Drop-in accessories and modifications can be found on page 149.

### Additional Warranties

Net Pricing

One year parts and labor contract ----- \$279

Two year parts and labor contract ----- \$523



# LT SERIES - DROP IN TRAY AND RACK DISPENSERS

## Product Information

### LT SERIES ONLY

- Top flange and bottom support to be 16-gauge stainless steel
- Dispenser body shall have four 14-gauge uprights, reinforced with 14-gauge stainless steel angles
- Top flange, uprights and bottom support to be integrally welded
- Dispenser platform carrier shall be 18-gauge stainless steel and removable for cleaning
- Self-leveling mechanisms shall be adjustable by adding and removing stainless steel extension springs located inside the elevator housing
- One year parts and 90 day labor standard warranty. Additional warranties available, see below



LT-1418

## Specifications and Prices

MODEL NUMBER	L	D	H	CUTOUT DIMENSION	MAXIMUM TRAY SIZE	AMP	SHIP WEIGHT	FREIGHT CLASS	LIST PRICE
<b>DROP-IN TRAY AND RACK DISPENSERS</b>									
LT-1014	15.75"	22.12"	27.5"	11.75" x 21"	10" x 15"	N/A	43	100	\$1,611
LT-1216	21.75"	19.12"	27.5"	17.75" x 18"	12" x 16"	N/A	43	100	\$1,652
LT-1221	26.75"	19.12"	27.5"	22.75" x 18"	12" x 21"	N/A	45	100	\$1,733
LT-1418	23.75"	21.12"	27.5"	19.75" x 20"	14" x 18"	N/A	43	100	\$1,743
LT-1422	27.75"	21.12"	27.5"	23.75" x 20"	14" x 22"	N/A	45	100	\$1,775
LT-1622	27.75"	23.12"	27.5"	23.75" x 22"	16" x 22"	N/A	45	100	\$1,796
LT-1826	31.75"	25.12"	27.5"	27.75" x 24"	18" x 26"	N/A	48	100	\$1,897
LT-2020	26.75"	27.12"	27.5"	22.75" x 26"	20" x 21"	N/A	45	100	\$1,897
<b>TWO STACK, DROP-IN TRAY AND RACK DISPENSERS</b>									
LT2-1014	27.75"	22.13"	27.5"	23.75" x 21"	11" x 15"	N/A	48	100	\$2,523
LT2-1216	23.12"	31.75"	27.5"	27.75" x 22"	12" x 16"	N/A	48	100	\$2,606
LT2-1221	31.75"	28.13"	27.5"	27.75" x 27"	12" x 21"	N/A	48	100	\$2,686

Drop-in accessories and modifications can be found on page 149.

### Additional Warranties

Net Pricing

One year parts and labor contract ----- \$279

Two year parts and labor contract ----- \$523



# MF/MFSC SERIES - BUILT IN MILK OR BEVERAGE DISPENSERS

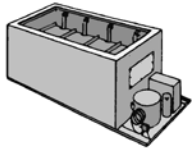

**MFSC-57**  
supplied with a lid

## Product Information

- Exterior body to be 20-gauge galvanized steel
- Units insulated with foamed in place polyurethane
- 1" IPS drain
- Opening throat liner to be high impact plastic
- Exterior frame to be 14-gauge galvanized
- Self-leveling mechanisms shall be adjustable by adding and removing stainless steel extension springs located inside the elevator housing
- (6) Anodized aluminum divider trays per opening on all units but MFSC-2020
- Dispenser platform carrier shall be 18-gauge stainless steel and removable for cleaning
- Insulated folding lid, stainless steel and high impact plastic
- One year parts and 90 day labor standard warranty. Additional warranties available, see below

### MF/MFSC SERIES ONLY

- Opening throat liner is high impact plastic
- (1) louver provided to be field installed

### MFSC SERIES ONLY

- Expansion valve
- Pressure control located near the condensing unit
- Cabinet shall maintain 36°F to 40°F (2°C to 4°C) with lids closed
- Refrigeration system shall be HFC-134A
- 9' cord and plug supplied

### MF SERIES ONLY

- An expansion valve and copper tubing connection to remote refrigeration system is provided
- Temperature and pressure control not provided

## Wire Basket Pricing

MODEL	# OF BASKETS	LIST PRICE
MF-2821	6	\$690
MFSC-2821	6	\$690
MF-31	12	\$1,381
MFSC-31	12	\$1,381
MF-44	18	\$2,071
MFSC-44	18	\$2,071
MF-57	24	\$2,760
MFSC-57	24	\$2,760
MF-2020	(NOT AVAILABLE)	
MFSC-2020	(NOT AVAILABLE)	

## Specifications and Prices

MODEL NUMBER	DIMENSIONS			CUTOUT DIMENSIONS	CAP	H.P.	AMP	VOLTS	NEMA PLUG	SHIP WEIGHT	FREIGHT CLASS	LIST PRICE
	L	D	H									

### BUILT-IN MILK OR BEVERAGE DISPENSERS — 40°F STORAGE ONLY

#### Self-contained

<b>MFSC-2020</b>	43.25"	26.25"	28.25"	(1) 25.25" x 22.25"	N/A	1/4	5.0	120	5-15P	303	110	<b>\$12,330</b>
<b>MFSC-2821</b>	28.5"	26.25"	28.25"	(1) 10.75" x 21"	126	1/4	5.0	120	5-15P	267	110	<b>\$10,037</b>
<b>MFSC-31</b>	42"	26.25"	28.25"	(2) 10.75" x 21"†	252	1/4	5.0	120	5-15P	306	110	<b>\$11,909</b>
<b>MFSC-44</b>	55.5"	26.25"	28.25"	(3) 10.75" x 21"†	378	1/4	5.0	120	5-15P	413	110	<b>\$13,497</b>
<b>MFSC-57</b>	69"	26.25"	28.25"	(4) 10.75" x 21"†	504	1/4	5.0	120	5-15P	461	110	<b>\$16,893</b>

\*Accommodates 20" x 20" racks. †Requires 2.75" between each cutout

#### Remote

<b>MF-2020</b>	29.25"	26.25"	28.25"	(1) 25.25" x 22.25"	N/A	N/A	N/A	N/A	N/A	240	110	<b>\$9,434</b>
<b>MF-2821</b>	14.5"	26.25"	28.25"	(1) 10.75" x 21"	126	N/A	N/A	N/A	N/A	197	110	<b>\$7,249</b>
<b>MF-31</b>	28"	26.25"	28.25"	(2) 10.75" x 21"†	252	N/A	N/A	N/A	N/A	238	110	<b>\$8,821</b>
<b>MF-44</b>	41.5"	26.25"	28.25"	(3) 10.75" x 21"†	378	N/A	N/A	N/A	N/A	312	110	<b>\$10,920</b>
<b>MF-57</b>	55"	26.25"	28.25"	(4) 10.75" x 21"†	504	N/A	N/A	N/A	N/A	335	110	<b>\$14,303</b>

\*MF-2020 accommodates 20" x 20" racks. †Requires 2.75" between each cutout.

Drop-in accessories and modifications can be found on page 149.

### Additional Warranties

Net Pricing

One year parts and labor contract ----- \$279

Two year parts and labor contract ----- \$523

Five year compressor warranty  
1/4 H.P. ----- \$108  
1/3 H.P. ----- \$128



## DROP INS

### 200/300

230 volt, 50 cycle electrical system (N225 and N227 only) -----	\$431
Locking device (N225, N225L, N227 and N227L only)-----	\$622
Pitcher filler in place of 12" glass filler (Part # M3234303)-----	\$371
Remote toggle switch assembly (shipped loose) for N225/N227(MK800033)-----	\$413

### N8000, N8100B, 8100-EF, N8200, N8600, N8700, N8800 & N8000N

208-240 volt, 60HZ, 1 phase step-down transformer (models w/compressors) - export orders only-----	\$746
230 volt, 50 HZ electrical system (models w/compressors) -----	\$431
230 volt, 50 HZ or 208-240 volt, 60 HZ electrical system (N8717-D,N8746ND, N8746N, N8731-D&N8831 only) -----	\$307
14-6, 14-8 or 14-10 adapter plates -----	\$284
14-1 - Telescoping cover (Per individual 12 x 20 well)-----	\$559
Additional 2" x 20.88" adapter bars-----	\$85
Additional .88" x 20.75" adapter bars -----	\$75
Additional .88" x 12.75" adapter bars -----	\$75
1" high perforated false bottoms (one pan size; 17.88" long units only)* -----	\$215
1" high perforated false bottoms (two pan size)*-----	\$366
1" high perforated false bottoms (three pan size)* -----	\$515
Single service flip-up sneeze guards (per linear inch)-----	\$43
Single service flip-up sneeze guard with lights (per linear inch)-----	\$62
Double service flip-up sneeze guards (per linear inch)-----	\$56
Double service flip-up sneeze guard with lights (per linear inch)-----	\$74
Plexiglas end panel (each) on sneeze guards-----	\$88
Fan assist package (cold units)-----	\$782
Adapter bars (N8100NB models only)-----	\$85
Relocate compressor (N8100B series) -----	\$959
Remote N8100B, 8100-EF, N8200, N8200G series (specify refrigerant)*Excludes N8100-FA Series ----- (CREDIT)	\$535
Three-phase electrical system (N8600 & N8700 Series only) -----	\$1,075
Omit drains N8700-D models	
N8717-D ----- (CREDIT)	\$194
N8731-D ----- (CREDIT)	\$216
N8745-D ----- (CREDIT)	\$253
N8759-D ----- (CREDIT)	\$292
N8773-D ----- (CREDIT)	\$327
N8787-D ----- (CREDIT)	\$381
Autofill kit (ship loose) for N8600 and N8800 (000-504-0030) -----	\$665
Autofill kit (ship loose) for N8700 (000-504-0031)-----	\$665
Remote toggle switch assembly (shipped loose) for N8100B, N8200, N8200G (MK800033)-----	\$413

## BUILT INS

### DIS SERIES

Shorten dispenser tubes to special length -----	add 10%
Stainless steel outer jacket for dispenser tubes (standard on DIS-ET & DIS-QT)-----	\$418
12" diameter stainless steel dish dispenser tray (DIS 1200 or 1450 only) -----	\$62
Non-marring rods or oval dishes and diameter adjustment (-813 through -1450 only) installation reduces dispenser diameter by 1.25" -----	\$471
Hold-down rod for dispenser tubes-----	\$117
220 volt, 50/60 cycle, single phase electrical connections-----	\$242
Stainless steel tube cover (-500 thru -725-ET and non-heated models)-----	\$374
Stainless steel dome cover (-813 through -1450 models only; standard on QT models; each)-----	\$505

### LT SERIES

Special heights-----	add 10%
Shorten dispenser assembly to special length (LT units only) -----	add 10%

### MF/MFSC SERIES

Lid locking device (specify unit)-----	\$654
220 volt, 50/60 cycle, single phase electrical connections-----	\$1,021
Wire basket (per three) (see page 131 for complete pricing)-----	\$345

**CAB2-** Mobile Enclosed Two Stack Dish Dispensers

**CAB3-** Mobile Enclosed Three Stack Dish Dispensers

**CAB4-** Mobile Enclosed Four Stack Dish Dispensers

**CT-** Mobile Cantilever Tray and Rack Dispensers

**T/T2-** Mobile Enclosed Tray and Rack Dispensers

**TT/TT2-** Mobile Open Frame Tray and Rack Dispensers

**FT2-SN-** Mobile Open Frame Tray and Rack Dispenser

**SALD-** Lettuce and Vegetable Spin Drier

**DT/DTC/RCD/UTS/UTSP/CPS/SS/UC/UC-** Utility Carts



# CAB2 - MOBILE ENCLOSED TWO STACK DISH DISPENSERS

## Product Information

### Cabinet

- Cabinet top to be 16-gauge stainless steel, welded, polished and reinforced
- Outer body and corners to be 20-gauge stainless steel
- Non-marring gray corner bumpers
- (4) 4.00" diameter polyolefin swivel casters (all locking)

### Dispensers

- Top flange and bottom brace to be 18-gauge stainless steel
- Vertical side channels 22-gauge stainless steel
- Flange, channels and bottom to be integrally welded
- Spring supports to be 14-gauge stainless steel
- Carrier head made of welded rods with a removable 18-gauge top plate
- Self-leveling mechanism, field adjustable by adding or removing springs

- High impact plastic guide posts mounted to flange

### QT/ET

- 9' cord and plug supplied
- Convection heating module and fan motor per dispenser
- Outer 22-gauge stainless steel jacket around dispenser
- Air intake shall be filtered
- On/off switch on each dispenser
- Each dispenser to have an adjustable thermostat
- QT- each dispenser shall have a stainless steel cover
- ET- Maintains temperatures between 120-140°F (49-60°C)
- QT- Maintains temperatures between 150-170°F (66-77°C)
- One year parts and 90 day labor standard warranty. Additional warranties available, see below



CAB2

## Laminate & Fiberglass Pricing Chart

Must specify color selection on order.

MODEL	LAMINATE PRICE	FIBERGLASS PANEL PRICE
CAB2-500	\$542	\$721
CAB2-575	\$542	\$721
CAB2-650	\$542	\$721
CAB2-725	\$542	\$721
CAB2-813	\$560	\$729
CAB2-913	\$560	\$729
CAB2-1013	\$560	\$729
CAB2-1200	\$560	\$747
CAB2-1450	\$608	\$770

For a complete list of fiberglass colors, contact Delfield or visit the website at [www.delfield.com](http://www.delfield.com).

## Specifications and Prices

MODEL NUMBER	L	D	H	DISH DIAMETER	AMPS	WATTS	VOLTS	NEMA PLUG	SHIP WEIGHT	FREIGHT CLASS	LIST PRICE
<b>MOBILE ENCLOSED TWO-STACK DISH DISPENSERS</b>											
<b>With unheated dispensers</b>											
CAB2-500	28.25"	17"	36"	3"-5"	N/A	N/A	N/A	N/A	125	100	\$2,877
CAB2-575	28.25"	17"	36"	5"-5.75"	N/A	N/A	N/A	N/A	125	100	\$2,995
CAB2-650	28.25"	17"	36"	5.75"-6.5"	N/A	N/A	N/A	N/A	127	100	\$3,135
CAB2-725	28.25"	17"	36"	6.5"-7.25"	N/A	N/A	N/A	N/A	130	100	\$3,226
CAB2-813	32.25"	17"	36"	7.25"-8.12"	N/A	N/A	N/A	N/A	132	100	\$3,321
CAB2-913	32.25"	17"	36"	8.12"-9.12"	N/A	N/A	N/A	N/A	135	100	\$3,511
CAB2-1013	32.25"	17"	36"	9.12"-10.12"	N/A	N/A	N/A	N/A	142	100	\$3,607
CAB2-1200	37"	19"	36"	10.13"-12"	N/A	N/A	N/A	N/A	160	100	\$4,081
CAB2-1450	42"	21.5"	36"	12"-14.5"	N/A	N/A	N/A	N/A	176	100	\$4,988
<b>With Even Temp heated dispensers</b>											
CAB2-500ET	28.25"	17"	36"	3"-5"	15.0	400	120	5-20P	144	125	\$4,326
CAB2-575ET	28.25"	17"	36"	5"-5.75"	15.0	400	120	5-20P	146	125	\$4,428
CAB2-650ET	28.25"	17"	36"	5.75"-6.5"	15.0	400	120	5-20P	148	125	\$4,605
CAB2-725ET	28.25"	17"	36"	6.5"-7.25"	15.0	400	120	5-20P	152	125	\$4,652
CAB2-813ET	32.25"	17"	36"	7.25"-8.12"	15.0	700	120	5-20P	160	125	\$4,758
CAB2-913ET	32.25"	17"	36"	8.12"-9.12"	15.0	700	120	5-20P	168	125	\$4,896
CAB2-1013ET	32.25"	17"	36"	9.12"-10.12"	15.0	700	120	5-20P	171	125	\$5,009
CAB2-1200ET	37"	19"	36"	10.12"-12"	15.0	700	120	5-20P	192	125	\$5,728
CAB2-1450ET	42"	21.5"	36"	12"-14.5"	15.0	700	120	5-20P	201	125	\$6,192
<b>With Quick Temp heated dispensers</b>											
CAB2-813QT	32.25"	17"	36"	7.25"-8.12"	15.0	700	120	5-20P	161	125	\$5,318
CAB2-913QT	32.25"	17"	36"	8.12"-9.12"	15.0	700	120	5-20P	166	125	\$5,358
CAB2-1013QT	32.25"	17"	36"	9.12"-10.12"	15.0	700	120	5-20P	169	125	\$5,568
CAB2-1200QT	37"	19"	36"	10.12"-12"	15.0	700	120	5-20P	186	125	\$6,423
CAB2-1450QT	42"	21.5"	36"	12"-14.5"	15.0	700	120	5-20P	201	125	\$6,951

Mobile Dispensing Equipment accessories and modifications can be found on page 159.

### Additional Warranties

	Net Pricing
One year parts and labor contract -----	\$279
Two year parts and labor contract-----	\$523

# CAB3 - MOBILE ENCLOSED THREE STACK DISH DISPENSERS



**CAB3-575**  
With optional wrap-around bumpers

## Laminate & Fiberglass Pricing Chart

Must specify color selection on order.

MODEL	LAMINATE PRICE	FIBERGLASS PANEL PRICE
CAB3-500	\$542	\$721
CAB3-575	\$542	\$721
CAB3-650	\$542	\$721
CAB3-725	\$542	\$721
CAB3-813	\$560	\$729
CAB3-913	\$560	\$729
CAB3-1013	\$560	\$729
CAB3-1200	\$560	\$747
CAB3-1450	\$608	\$770

For a complete list of fiberglass colors, contact Delfield or visit the website at [www.delfield.com](http://www.delfield.com).

### Additional Warranties

Net Pricing

One year parts and labor contract ----- \$279

Two year parts and labor contract ----- \$523

## Product Information

### Cabinet

- Cabinet top to be 16-gauge stainless steel, welded, polished and reinforced
- Outer body and corners to be 20-gauge stainless steel
- Non-marring gray corner bumpers
- (4) 4.00" diameter polyolefin swivel casters (all locking)

### Dispensers

- Top flange and bottom brace to be 18-gauge stainless steel
- Vertical side channels 22-gauge stainless steel
- Flange, channels and bottom to be integrally welded
- Spring supports to be 14-gauge stainless steel
- Carrier head made of welded rods with a removable 18-gauge top plate
- Self-leveling mechanism, field adjustable by adding or removing springs
- High impact plastic guide posts mounted to flange

### QT/ET

- 9' cord and plug supplied
- Convection heating module and fan motor per dispenser
- Outer 22-gauge stainless steel jacket around dispenser
- Air intake shall be filtered
- On/off switch on each dispenser
- Each dispenser to have an adjustable thermostat
- QT- Each dispenser shall have a stainless steel cover
- ET- Maintains temperatures between 120-140°F (49-60°C)
- QT- Maintains temperatures between 150-170°F (66-77°C)
- One year parts and 90 day labor standard warranty. Additional warranties available, see below

## Specifications and Prices

MODEL NUMBER	L	D	H	DISH DIAMETER	AMPS	WATTS	VOLTS	NEMA PLUG	SHIP WEIGHT	FREIGHT CLASS	LIST PRICE
<b>MOBILE ENCLOSED THREE-STACK DISH DISPENSERS</b>											
<b>With unheated dispensers</b>											
CAB3-500	41.25"	17"	36"	3"-5"	N/A	N/A	N/A	N/A	173	100	\$3,705
CAB3-575	41.25"	17"	36"	5"-5.75"	N/A	N/A	N/A	N/A	176	100	\$3,830
CAB3-650	41.25"	17"	36"	5.75"-6.5"	N/A	N/A	N/A	N/A	177	100	\$4,240
CAB3-725	41.25"	17"	36"	6.5"-7.25"	N/A	N/A	N/A	N/A	179	100	\$4,397
CAB3-813	47.25"	17"	36"	7.25"-8.12"	N/A	N/A	N/A	N/A	190	100	\$4,652
CAB3-913	47.25"	17"	36"	8.12"-9.12"	N/A	N/A	N/A	N/A	193	100	\$4,789
CAB3-1013	47.25"	17"	36"	9.12"-10.12"	N/A	N/A	N/A	N/A	196	100	\$4,896
CAB3-1200	53.25"	19"	36"	10.12"-12"	N/A	N/A	N/A	N/A	212	100	\$5,895
CAB3-1450	62"	21.5"	36"	12"-14.5"	N/A	N/A	N/A	N/A	229	100	\$6,570
<b>With Even Temp heated dispensers</b>											
CAB3-500ET	41.25"	17"	36"	3"-5"	13.0	400	208	6-20P	207	125	\$5,761
CAB3-575ET	41.25"	17"	36"	5"-5.75"	13.0	400	208	6-20P	210	125	\$5,878
CAB3-650ET	41.25"	17"	36"	5.75"-6.5"	13.0	400	208	6-20P	213	125	\$6,495
CAB3-725ET	41.25"	17"	36"	6.5"-7.25"	13.0	400	208	6-20P	219	125	\$6,521
CAB3-813ET	47.25"	17"	36"	7.25"-8.12"	13.0	700	208	6-20P	233	125	\$6,761
CAB3-913ET	47.25"	17"	36"	8.12"-9.12"	13.0	700	208	6-20P	239	125	\$6,990
CAB3-1013ET	47.25"	17"	36"	9.12"-10.12"	13.0	700	208	6-20P	245	125	\$7,163
CAB3-1200ET	53.25"	19"	36"	10.12"-12"	13.0	700	208	6-20P	262	125	\$8,195
CAB3-1450ET	62"	21.5"	36"	12"-14.5"	13.0	700	208	6-20P	277	125	\$8,722
<b>With Quick Temp heated dispensers</b>											
CAB3-813QT	47.25"	17"	36"	7.25"-8.12"	13.0	700	208	6-20P	243	125	\$7,364
CAB3-913QT	47.25"	17"	36"	8.12"-9.12"	13.0	700	208	6-20P	249	125	\$7,805
CAB3-1013QT	47.25"	17"	36"	9.12"-10.12"	13.0	700	208	6-20P	255	125	\$8,363
CAB3-1200QT	53.25"	19"	36"	10.12"-12"	13.0	700	208	6-20P	272	125	\$8,837
CAB3-1450QT	62"	21.5"	36"	12"-14.5"	13.0	700	208	6-20P	287	125	\$9,281

Mobile Dispensing Equipment accessories and modifications can be found on page 159.





# CAB4 - MOBILE ENCLOSED FOUR STACK DISH DISPENSERS

## Product Information

### Cabinet

- Cabinet top to be 16-gauge stainless steel, welded, polished and reinforced
- Outer body and corners to be 20-gauge stainless steel
- Non-marring gray corner bumpers
- (4) 4.00" diameter polyolefin swivel casters (all locking)

### Dispensers

- Top flange and bottom brace to be 18-gauge stainless steel
- Vertical side channels 22-gauge stainless steel
- Flange, channels and bottom to be integrally welded
- Spring supports to be 14-gauge stainless steel
- Carrier head made of welded rods with a removable 18-gauge top plate
- Self-leveling mechanism, field adjustable by adding or removing springs
- High impact plastic guide posts mounted to flange

### QT/ET

- 9' cord and plug supplied
- Convection heating module and fan motor per dispenser
- Outer 22-gauge stainless steel jacket around dispenser
- Air intake shall be filtered
- On/off switch on each dispenser
- Each dispenser to have an adjustable thermostat
- QT- Each dispenser shall have a stainless steel cover
- ET- Maintains temperatures between 120-140°F (49-60°C)
- QT- Maintains temperatures between 150-170°F (66-77°C)
- One year parts and 90 day labor standard warranty. Additional warranties available, see below



CAB4-813

### Laminate & Fiberglass Pricing Chart

Must specify color selection on order.

MODEL	LAMINATE PRICE	FIBERGLASS PANEL PRICE
CAB4-500	\$542	\$721
CAB4-575	\$542	\$721
CAB4-650	\$542	\$721
CAB4-725	\$542	\$721
CAB4-813	\$560	\$729
CAB4-913	\$560	\$729
CAB4-1013	\$560	\$729
CAB4-1200	\$560	\$747
CAB4-1450	\$608	\$770

For a complete list of fiberglass colors, contact Delfield or visit the website at [www.delfield.com](http://www.delfield.com).

## Specifications and Prices

MODEL NUMBER	L	D	H	DISH DIAMETER	AMPS	WATTS	VOLTS	NEMA PLUG	SHIP WEIGHT	FREIGHT CLASS	LIST PRICE
<b>MOBILE ENCLOSED FOUR-STACK DISH DISPENSERS</b>											
<b>With unheated dispensers</b>											
CAB4-500	27"	27"	36"	3"-5"	N/A	N/A	N/A	N/A	181	100	\$4,808
CAB4-575	27"	27"	36"	5"-5.75"	N/A	N/A	N/A	N/A	185	100	\$5,074
CAB4-650	27"	27"	36"	5.75"-6.5"	N/A	N/A	N/A	N/A	186	100	\$5,244
CAB4-725	27"	27"	36"	6.5"-7.25"	N/A	N/A	N/A	N/A	189	100	\$5,391
CAB4-813	32.25"	32.25"	36"	7.25"-8.12"	N/A	N/A	N/A	N/A	213	100	\$5,930
CAB4-913	32.25"	32.25"	36"	8.12"-9.12"	N/A	N/A	N/A	N/A	217	100	\$6,316
CAB4-1013	32.25"	32.25"	36"	9.12"-10.12"	N/A	N/A	N/A	N/A	221	100	\$6,640
CAB4-1200	36"	36"	36"	10.12"-12"	N/A	N/A	N/A	N/A	240	100	\$7,775
CAB4-1450	42"	42"	36"	12"-14.5"	N/A	N/A	N/A	N/A	263	100	\$10,037
<b>With Even Temp heated dispensers</b>											
CAB4-500ET	27"	27"	36"	3"-5"	17.0	400	208	6-20P	226	125	\$7,278
CAB4-575ET	27"	27"	36"	5"-5.75"	17.0	400	208	6-20P	230	125	\$7,614
CAB4-650ET	27"	27"	36"	5.75"-6.5"	17.0	400	208	6-20P	234	125	\$8,058
CAB4-725ET	27"	27"	36"	6.5"-7.25"	17.0	400	208	6-20P	242	125	\$8,393
CAB4-813ET	32.25"	32.25"	36"	7.25"-8.12"	17.0	700	208	6-20P	270	125	\$8,924
CAB4-913ET	32.25"	32.25"	36"	8.12"-9.12"	17.0	700	208	6-20P	278	125	\$9,253
CAB4-1013ET	32.25"	32.25"	36"	9.12"-10.12"	17.0	700	208	6-20P	286	125	\$9,608
CAB4-1200ET	36"	36"	36"	10.12"-12"	17.0	700	208	6-20P	313	125	\$10,643
CAB4-1450ET	42"	42"	36"	12"-14.5"	17.0	700	208	6-20P	337	125	\$11,225
<b>With Quick Temp heated dispensers</b>											
CAB4-813QT	32.25"	32.25"	36"	7.25"-8.12"	17.0	700	208	6-20P	290	125	\$9,599
CAB4-913QT	32.25"	32.25"	36"	8.12"-9.12"	17.0	700	208	6-20P	298	125	\$9,946
CAB4-1013QT	32.25"	32.25"	36"	9.12"-10.1"	17.0	700	208	6-20P	306	125	\$10,294
CAB4-1200QT	36"	36"	36"	10.12"-12"	17.0	700	208	6-20P	333	125	\$11,328
CAB4-1450QT	42"	42"	36"	12"-14.5"	17.0	700	208	6-20P	351	125	\$11,950

Mobile Dispensing Equipment accessories and modifications can be found on page 159.

### Additional Warranties

Net Pricing

One year parts and labor contract ----- \$279

Two year parts and labor contract ----- \$523

## CT - MOBILE CANTILEVER TRAY AND RACK DISPENSERS



CT-1826

## Product Information

- Elevating mechanism cabinet to be 14-gauge stainless steel
- Base to be 14-gauge stainless steel, reinforced with 14-gauge stainless steel support channels
- (4) 4.00" diameter polyolefin swivel casters (all locking)
- Non-marring gray corner bumpers
- Dispenser platform carrier to be 16-gauge stainless steel and mounted on two stainless steel cantilever arms
- Self-leveling mechanisms shall be adjustable by adding or removing stainless steel extension springs located behind removable panel
- One year parts and 90 day labor standard warranty. Additional warranties available, see below

## Specifications and Prices

MODEL NUMBER	L	D	H	MAXIMUM TRAY SIZE	SHIP WEIGHT	FREIGHT CLASS	LIST PRICE
<b>MOBILE CANTILEVER TRAY AND RACK DISPENSERS</b>							
CT-1216	13"	22"	37"	12" x 16"	106	100	\$3,705
CT-1221	13"	27.88"	37"	12" x 21"	132	100	\$3,723
CT-1418	15"	27.88"	37"	14" x 18"	145	100	\$3,778
CT-1422	15"	27.88"	37"	14" x 22"	145	100	\$3,808
CT-1622	17.25"	27.88"	37"	16" x 22"	159	100	\$3,891
CT-1826	21"	31.75"	37"	18" x 26"	165	100	\$4,123
CT-2020	21"	27.88"	37"	20" x 21"	168	100	\$4,123

Mobile Dispensing Equipment accessories and modifications can be found on page 159.

## Additional Warranties

Net Pricing

One year parts and labor contract----- \$279

Two year parts and labor contract----- \$523



# T AND T2 - MOBILE ENCLOSED TRAY AND RACK DISPENSERS

## Product Information

### T SERIES ONLY

- Cabinet top to be 16-gauge stainless steel, welded, polished and reinforced
- Cabinet sides to be 20-gauge stainless steel
- Cabinet bottom to be 14-gauge galvanized steel
- (4) 4.00" polyolefin swivel casters (all locking)
- Dispenser platform carrier shall be 18-gauge stainless steel and removable for cleaning
- Non-marking corner gray bumpers
- Self-leveling mechanisms shall be adjustable by adding and removing stainless steel extension springs located inside the elevator housing
- One year parts and 90 day labor standard warranty. Additional warranties available, see below

### T/T2-H SERIES ONLY

- Heated dispenser has a stainless steel liner and 2.00" of fiberglass insulation
- On/off switch and 9' cord and plug standard
- Dispenser is heated with convection heated modules
- Air intake is standard with filter
- Adjustable thermostat
- Temperatures between 150-170° F. (66-77°C)
- One year parts and 90 day labor standard warranty. Additional warranties available, see below



T-1418



interior view of T-1418

## Specifications and Prices

MODEL NUMBER	L	DIMENSIONS D	H	MAXIMUM TRAY SIZE	AMP	VOLTS	NEMA PLUG	SHIP WEIGHT	FREIGHT CLASS	LIST PRICE
<b>MOBILE ENCLOSED TRAY AND RACK DISPENSERS</b>										
T-1014	23.12"	16.75"	36"	10" x 15"	N/A	N/A	N/A	150	100	\$4,785
T-1216	22.75"	20.12"	36"	12" x 16"	N/A	N/A	N/A	153	100	\$4,785
T-1221	27.75"	20.12"	36"	12" x 21"	7.0	N/A	N/A	162	100	\$4,826
T-1418	24.75"	22.12"	36"	14" x 18"	7.0	N/A	N/A	153	100	\$4,807
T-1422	28.75"	22.12"	36"	14" x 22"	7.0	N/A	N/A	162	100	\$4,807
T-1622	28.75"	24.12"	36"	16" x 22"	N/A	N/A	N/A	177	100	\$4,852
T-1826	32.75"	26.12"	36"	18" x 26"	14.0	N/A	N/A	210	100	\$5,159
T-2020	27.75"	28.12"	36"	20" x 21"	14.0	N/A	N/A	175	100	\$4,874
<b>TWO STACK, MOBILE ENCLOSED TRAY AND RACK DISPENSERS</b>										
T2-1014	27.75"	22.12"	36"	10" x 15"	N/A	N/A	N/A	177	100	\$5,269
T2-1216	32.75"	24.12"	36"	12" x 16"	N/A	N/A	N/A	177	100	\$5,269
T2-1221	32.75"	29.12"	36"	12" x 21"	7.0	N/A	N/A	185	100	\$5,269
<b>HEATED MOBILE ENCLOSED TRAY AND RACK DISPENSERS</b>										
T-1221H	27.75"	20.12"	36"	12" x 21"	7.0	120	5-15P	127	125	\$7,033
T-1418H	24.75"	22.12"	36"	14" x 18"	7.0	120	5-15P	155	125	\$7,131
T-1422H	28.75"	22.12"	36"	14" x 22"	7.0	120	5-20P	155	125	\$7,489
T-1826H	32.75"	26.12"	36"	18" x 26"	14.0	120	5-20P	195	125	\$7,542
T-2020H	27.75"	28.12"	36"	20" x 21"	14.0	120	5-20P	185	125	\$7,131
<b>TWO STACK, HEATED MOBILE ENCLOSED TRAY AND RACK DISPENSERS</b>										
T2-1221H	32.75"	29.12"	36"	12" x 21"	7.0	120	5-20P	185	125	\$7,542

Mobile Dispensing Equipment accessories and modifications can be found on page 159.

### Laminate & Fiberglass Pricing Chart

Must specify color selection on order.

MODEL	LAMINATE PRICE	FIBERGLASS PANEL PRICE
T-1014	\$549	\$721
T-1216	\$549	\$721
T-1221	\$549	\$721
T-1418	\$549	\$721
T-1422	\$587	\$760
T-1622	\$587	\$760
T-1826	\$587	\$760
T-2020	\$587	\$760
all T2's	\$600	\$780
all T-H's	\$588	\$665

For a complete list of fiberglass colors, contact Delfield or visit the website at [www.delfield.com](http://www.delfield.com).

### Additional Warranties

Net Pricing

One year parts and labor contract ----- \$279

Two year parts and labor contract ----- \$523



# TT AND TT2 - MOBILE OPEN FRAME TRAY AND RACK DISPENSERS



TT-1422

## Product Information

- Tubing and base to be 16-gauge stainless steel
- Tubing and base to be integrally welded
- Base to be reinforced with 14-gauge stainless steel angles
- Non-marring gray corner bumpers
- (4) 4.00" diameter polyolefin swivel casters (all locking)
- Dispenser platform carrier shall be 18-gauge stainless steel
- Self-leveling mechanisms shall be adjustable by adding and removing stainless steel extension springs located inside the elevator housing
- Each dispenser section holds 50-60 trays (varies per tray)
- One year parts and 90 day labor standard warranty. Additional warranties available, see below



TT2-1418

## Specifications and Prices

MODEL NUMBER	L	DIMENSIONS D	H	MAXIMUM TRAY SIZE	SHIP WEIGHT	FREIGHT CLASS	LIST PRICE
<b>MOBILE OPEN FRAME TRAY AND RACK DISPENSERS</b>							
TT-1014	21.25"	15.25"	37.75"	11" x 15"	102	100	\$3,053
TT-1216	18.25"	20.75"	37.75"	12" x 16"	102	100	\$3,124
TT-1221	18.25"	25.75"	37.75"	12" x 21"	105	100	\$3,199
TT-1418	20.25"	22.75"	37.75"	14" x 18"	102	100	\$3,199
TT-1422	20.25"	26.75"	37.75"	14" x 22"	105	100	\$3,199
TT-1622	22.25"	26.75"	37.75"	16" x 22"	106	100	\$3,298
TT-1826	24.25"	30.75"	37.75"	18" x 26"	111	100	\$3,334
TT-2020	26.25"	25.75"	37.75"	20" x 21"	111	100	\$3,334
<b>TWO STACK, MOBILE OPEN FRAME TRAY AND RACK DISPENSERS</b>							
TT2-1014	21.25"	26.75"	37.75"	11" x 15"	113	100	\$3,663
TT2-1216	36.5"	20.75"	37.75"	12" x 16"	165	100	\$4,184
TT2-1221	36.5"	25.75"	37.75"	12" x 21"	163	100	\$4,419
TT2-1418	40.5"	22.75"	37.75"	14" x 18"	165	100	\$4,419
TT2-1422	40.5"	26.75"	37.75"	14" x 22"	163	100	\$4,419
TT2-1622	44.5"	26.75"	37.75"	16" x 22"	170	100	\$4,652
TT2-1826	48.5"	30.75"	37.75"	18" x 26"	179	100	\$4,881
TT2-2020	52.5"	25.75"	37.75"	20" x 21"	179	100	\$4,881

Mobile Dispensing Equipment accessories and modifications can be found on page 159.

### Additional Warranties

Net Pricing

One year parts and labor contract ----- \$279

Two year parts and labor contract ----- \$523



# FT2-SN - MOBILE OPEN FRAME TRAY AND RACK DISPENSER SALD-1 - LETTUCE AND VEGETABLE SPIN DRIER

## Product Information

### FT2-SN SERIES ONLY

- Tubing and base is 16-gauge stainless steel
- Tubing and base is integrally welded
- Base to be reinforced with 14-gauge stainless steel angles
- Center housing to be two-piece molded fiberglass
- Center housing top to be 16-gauge stainless steel, which houses two napkin dispensers
- Silverware bin to have (10) holes and made of stainless steel
- Plastic silverware cylinders provided standard
- Non-marring gray corner bumpers
- (4) 4.00" diameter polyolefin swivel casters (all locking)
- Dispenser platform carrier shall be 18-gauge stainless steel
- Self-leveling mechanisms shall be adjustable by adding and removing stainless steel extension springs located inside the elevator housing

### SALD-1/ SALD-2 SERIES ONLY

- Body is 18-gauge stainless steel
- Legs are 1" diameter 16-gauge stainless steel tubing
- (3) 4.00" diameter polyolefin locking stem casters
- Outer lid is 18-gauge stainless steel
- Inner liner is perforated durable polyethylene plastic
- Water-tight motor and controls are mounted on the bottom of the unit
- 6' cord and plug supplied
- Unit has 1.50" drain
- Adjustable ON/OFF timer for drying times up to 5 minutes
- Lid and cover storing hooks come standard
- SALD-1 & SALD-2 can not be shipped via UPS



FT2-SN-1418



SALD-1

## Specifications and Prices

MODEL NUMBER	L	DIMENSIONS D H		MAXIMUM TRAY SIZE	SHIP WEIGHT	FREIGHT CLASS	LIST PRICE
<b>TWO STACK, MOBILE OPEN FRAME TRAY AND RACK DISPENSERS</b> with silverware bin and napkin dispensers Fiberglass, Specify Color							
FT2-SN-1216	43.75"	22.12"	56.38"	12" x 16"	284	100	<b>\$8,195</b>
FT2-SN-1418	47.75"	22.12"	56.38"	14" x 18"	298	100	<b>\$8,195</b>
FT2-SN-1622	51.75"	22.12"	56.38"	16" x 22"	306	100	<b>\$8,195</b>

### TWO STACK, MOBILE OPEN FRAME TRAY AND RACK DISPENSERS with silverware bin and napkin dispensers

MODEL NUMBER	L	D	H	INNER LINER CAPACITY	INNER DIAMETER	LINER DEPTH	AMPS	VOLTS	NEMA PLUG	SHIP WEIGHT	FREIGHT CLASS	LIST PRICE
Stainless Steel												
FT2-SN-1216SS	43.75"	22.12"	56.38"	12" x 16"	284	100	<b>\$7,809</b>					
FT2-SN-1418SS	47.75"	22.12"	56.38"	14" x 18"	298	100	<b>\$7,809</b>					
FT2-SN-1622SS	51.75"	22.12"	56.38"	16" x 22"	306	100	<b>\$8,195</b>					

MODEL NUMBER	L	D	H	INNER LINER CAPACITY	INNER DIAMETER	LINER DEPTH	AMPS	VOLTS	NEMA PLUG	SHIP WEIGHT	FREIGHT CLASS	LIST PRICE
<b>SALAD ACE LETTUCE AND VEGETABLE SPIN DRIER</b>												
SALD-1	27"	27"	32.5"	20 gal.	15.62"	16.87"	2.7	115	5-15P	70	85	<b>\$4,565</b>
SALD-2	27"	27"	32.5"	20 gal.	15.62"	16.87"	1.35	230	5-15P	70	85	<b>\$4,976</b>

Mobile Dispensing Equipment accessories and modifications can be found on page 159.

MOBILE DISPENSING EQUIPMENT

Additional Warranties	
	Net Pricing
One year parts and labor contract -----	\$279
Two year parts and labor contract -----	\$523

# UTS, UTSP, UC AND UCE - UTILITY CARTS



**UTS-1**



**UC-3**

## Product Information

### UTS SERIES ONLY

- Silverware bin to have (10) holes made of stainless steel
- Plastic silverware cylinders provided standard

### UTSP SERIES ONLY

- Silverware bin to accommodate ¼ size pans (provided) made of stainless steel
- UTSP-1 holds (4) pans and UTSP-2 holds (8) pans

### ALL UNITS

- Tray shelves to be one piece molded fiberglass
- Tray shelves to be 14-gauge stainless steel on SS models only
- (4) 4.00" diameter polyolefin swivel casters (all locking)
- Non-marring vinyl sleeve bumper at each corner
- Vertical upper 1.00" diameter 16-gauge tubing frame and tubing bottom to be integrally welded
- One year parts and 90 day labor standard warranty. Additional warranties available, see below

## Specifications and Prices

MODEL NUMBER	L	DIMENSIONS D	H	SHIP WEIGHT	FREIGHT CLASS	LIST PRICE
<b>TRAY AND SILVERWARE CARTS AND STARTER OVERSHELVES</b>						
UTS-1	35.25"	23.37"	46.69"	120	100	\$2,745
UTS-1SS	35.25"	23.37"	46.69"	125	100	\$2,615
UTSP-1	35.25"	23.37"	46.69"	125	100	\$3,047
UTSP-1SS	35.25"	23.37"	46.69"	130	100	\$3,067
UTSP-2	35.25"	23.37"	46.69"	140	100	\$4,019
UTSP-2SS	35.25"	23.37"	60.62"	145	100	\$3,965
<b>UTILITY CARTS</b>						
UC-2	35.25"	23.37"	35.75"	115	100	\$2,370
UC-2SS	35.25"	23.37"	35.75"	125	100	\$1,828
UC-3	35.25"	23.37"	35.75"	125	100	\$2,945
UC-3SS	35.25"	23.37"	35.75"	135	100	\$2,274
UCE-1727SS	25.25"	17"	35.75"	110	100	\$1,903

Mobile Dispensing Equipment accessories and modifications can be found on page 159.

### Additional Warranties

Net Pricing

One year parts and labor contract ----- \$279

Two year parts and labor contract ----- \$523



## CAB2, CAB3, AND CAB4 SERIES

12" diameter stainless steel dish dispenser tray (-1200 and -1450 models only)-----	\$62
Non-marring rods for oval dishes and diameter adjustment (-813 through -1450 only) per dispenser installation reduces dispenser diameter by 1.25"-----	\$471
Stainless steel tube cover (-500 thru -725-ET and non-heated models)-----	\$374
Stainless steel dome cover (-813 through -1450 models only; standard on QT models; each)-----	\$505
Hold-down rod for dispenser tubes-----	\$117
Wrap-around bumpers (-500 through -1200 only; adds 1.75" to length and depth)-----	\$462
Wrap-around bumpers (-1450 only; adds 1.75" to length and depth) ---	\$591
Four 4" diameter polyurethane casters (four locking) in lieu of standard casters-----	\$566
Four 5" diameter polyurethane casters (four locking) in lieu of standard casters-----	\$678
Flange-mount feet in lieu of standard casters-----	\$263
CAB2-220 volt, 50/60 cycle, single phase electrical connections-----	\$315
CAB3-220 volt, 50/60 cycle, single phase electrical connections-----	\$415
CAB4-220 volt, 50/60 cycle, single phase electrical connections-----	\$510
Shorten dispenser tubes to special length-----	add 10%

## CT SERIES

Wrap-around bumpers for CT models (adds 1.75" to length and depth)	\$456
Flange-mount feet in lieu of standard polyolefin casters (CT models)---	\$263
Four 4" diameter heavy duty polyurethane casters (CT models)-----	\$566
Four 5" diameter heavy duty polyurethane casters (CT models)-----	\$678
One pair napkin dispensers (CT models)-----	\$345
Six (6) hole silverware bins (CT models)-----	\$765
Eight (8) hole silverware bins (CT models)-----	\$1,141
Ten (10) hole silverware bin-----	\$1,171
Stainless steel silverware cylinder in lieu of standard plastic cylinder; CT models; (each)-----	\$59
Additional plastic silverware cylinder; CT models; (each)-----	\$39
Additional stainless steel silverware cylinder; CT models; (each)-----	\$90
Push handles (CT models)-----	\$478
Special heights (CT models)-----	add 10%

## T AND T2 SERIES

Wrap-around bumpers (adds 1.75" to length and depth)-----	\$456
Flange-mount feet in lieu of standard polyolefin casters-----	\$263
Four 4" diameter heavy duty polyurethane casters-----	\$566
Four 5" diameter heavy duty polyurethane casters-----	\$678
One pair napkin dispensers-----	\$345
Six (6) hole silverware bin-----	\$765
Eight (8) hole silverware bin-----	\$1,013
Ten (10) hole silverware bin-----	\$1,173
Additional plastic silverware cylinder (each)-----	\$39
Additional stainless steel silverware cylinder (each)-----	\$90
Stainless steel silverware cylinder in lieu of standard plastic cylinder (each)-----	\$59
220 volt, 50/60 cycle, single phase electrical connections (T2 models only)-----	\$447
Special heights-----	add 10%
Stainless steel dust cover-----	\$524

## FT2-SN

Flange-mount feet in lieu of standard polyolefin casters-----	\$263
Four 4" diameter heavy duty polyurethane casters-----	\$566
Four 5" diameter heavy duty polyurethane casters-----	\$678
Additional plastic silverware cylinder-----	\$39
Additional stainless steel silverware cylinder-----	\$90
Stainless steel silverware cylinder in lieu of standard plastic cylinder-----	\$59
Special heights-----	add 10%

## SALD MODELS

Extra polyurethane liner and inner lid (for SALD-1)-----	\$293
--	-------

## UTS, UTSP, CPS, SS, UC AND UCE

Four 4" diameter heavy duty polyurethane casters with corner bumpers-----	\$566
Four 5" diameter heavy duty polyurethane casters with corner bumpers-----	\$678
Rolling bumpers (adds 2.5" to length & depth)-----	\$156
One pair napkin dispensers (UTS & UTS-SS only)-----	\$345
Additional plastic silverware cylinder (UTS & UTS-SS only)(6230022)---	\$39
Additional stainless steel silverware cylinder (UTS & UTS-SS only)(3234052)-----	\$90
Stainless steel silverware cylinder in lieu of standard plastic cylinder (UTS & UTS-SS only)-----	\$59
12" x 20" x 2.5" deep stainless steel pans (CPS & SS only; each)-----	\$218
Six (6) hole silverware bin-----	\$759
Eight (8) hole silverware bin-----	\$1,013
Ten (10) hole silverware bin-----	\$1,173

MOBILE DISPENSING EQUIPMENT



# DOMESTIC U.S. TERMS AND CONDITIONS

- Prices.** Unless otherwise specifically agreed, all prices are for material packed for domestic shipment and for delivery F.O.B. point of manufacture. Acceptance of your order is based on present costs, and the prices set forth herein are subject to increase by Seller at any time prior to delivery in respect to all or any portion of the material on order to the extent necessary to cover Seller's increased costs applicable thereto.
- Delivery.** Shipping dates are approximate and based on prompt receipt of all necessary information. All risks of loss shall be on the Buyer from point of shipment. Buyer shall pay all transportation and delivery charges to final destination.
- Default.** If Buyer shall fail or refuse to accept delivery of the equipment or parts ordered hereunder or should default in the performance of any of the terms, covenants and conditions of this agreement, Seller may retain the cash deposited or paid to it and/or equipment accepted by it on account of the sale price and apply the same toward payment of its damages.
- Delays.** Seller shall not be liable for loss or damage due to delay in delivery, manufacture or installation resulting from any cause beyond Seller's reasonable control, including but not limited to, compliance with any regulation, orders or instructions of any federal, state or municipal government or any department or any agency thereof, acts of nature, acts or omissions of the Buyer, acts of civil or military authority, fires, strikes, factory shutdowns or alterations, embargoes, wars, riot, delays in transportation, or inability due to cause beyond the Seller's reasonable control to obtain necessary labor or materials from the Seller's usual sources; and any delays resulting from any such cause shall constitute cause for extending delivery dates and receipt of the goods shall constitute a waiver of all claims for damage. In no event shall Seller be liable for special or consequential damages.
- Payment Terms.** The terms of sale herein are subject to credit approval and Seller may at any time prior to delivery modify the terms of payment originally specified to require payment in advance. Lacking credit approval, sales will be made on a cash with order, *pro forma* invoice or cash on delivery basis. All printed prices are quoted F.O.B. Factory, subject to terms as printed and subject to change without notice.  
If the total selling price is not paid when due, buyer shall pay late charges equal to the highest lawful contract rate of interest not to exceed 1 1/2% per month computed from the due date on the unpaid balance of the total selling price.
- Specifications.** Quantities and sizes are subject to variation in accordance with Seller's standard practices, tolerances and the requirements of the job where the equipment covered by this order is to be installed.
- Installation.** If the order acknowledgment provides for installation, Seller's obligation to deliver the equipment and provide for its installation shall in no event commence until the premises are ready to receive the equipment, and such obligations shall be subject to all the other terms hereof. Costs and expenses to Seller or its contractor due to delays in installation caused by interference by other contractors working on the premises will be charged to Buyer. Installation costs stated in this order are estimated, cover only installation of the equipment specified herein, and do not cover any other costs, including, but not limited to, costs of electrical work, carpentry, plumbing, sweeping, mopping, dusting or general cleanup. Seller or its contractor shall not be responsible for removing or disposing of packing material, cartons, boxes or other containers housing the equipment.
- Taxes.** The amount of taxes stated on the order, if any, is approximate only. Buyer is liable for the full amount of all taxes applicable to or as a result of a transaction, exclusive of franchise taxes and taxes measured by the net income of Seller. Buyer shall pay the amount of all such taxes at any time requested by Seller as if originally added to the price. If Seller pays the taxes, Buyer shall reimburse Seller therefor.
- Insurance.** Buyer shall provide and maintain adequate insurance for the product delivered against loss or damages by fire or other causes during the time between delivery and final payment, in an amount fully protecting Seller, and loss or damage by fire or other causes within such period shall not relieve Buyer from its obligations under this contract. Buyer shall provide and maintain adequate liability and workmen's compensation insurance covering all workers who may assist in the erection of product delivered.
- Cancellation.** Buyer may cancel its order, reduce quantities, revise specifications or extend schedules only by mutual agreement as to reasonable and proper cancellation charges which shall take into account expenses already incurred and commitments made by Seller, and Buyer shall indemnify Seller against any loss.
- Standard One-Year Warranty.** The Delfield Company ("Delfield") warrants to the Original Purchaser of the Delfield product (herein called the "Unit") that such Unit, and all parts thereof, will be free from defects in material and workmanship under normal use and service for a period of one (1) year from the date of shipment of the Unit to the Original Purchaser or, if the Original Purchaser returns the warranty card completely filled out including the date of installation within thirty (30) days of receipt of the Unit, one (1) year from the date of installation. During this one year warranty period, Delfield will repair or replace any defective part or portion thereof returned to Delfield by the Original Purchaser which Delfield determines was defective due to faulty material or workmanship. The Original Purchaser will pay all labor, crating, freight and related costs incurred in the removal of the Unit or

defective component and shipment to Delfield, except that during a period of either ninety (90) days from the date of shipment of the Unit to the Original Purchaser or, if the Original Purchaser returns the warranty card completely filled out including the date of installation within thirty (30) days of receipt of the Unit, ninety (90) days from the date of installation Delfield will pay all related labor costs. Delfield will pay the return costs if the Unit or part thereof was defective.

The term "Original Purchaser" as used herein means that person, firm, association, or corporation for whom the Unit was originally installed.

This Warranty does not apply to any Unit or part thereof that has been subjected to misuse, neglect, alteration, or accident, such as accidental damage to the exterior finish; operated contrary to the recommendations specified by Delfield; or repaired or altered by anyone other than Delfield in any way so as to, in Delfield's sole judgment, affect its quality or efficiency. This Warranty does not apply to any Unit that has been moved from the location where it was originally installed. **This Warranty also does not cover the refrigerator drier or the light bulbs used in the Unit. The warranty is subject to the user's normal maintenance and care responsibility as set forth in the Service and Installation Manual, such as cleaning the condenser coil, and is in lieu of all other obligations of Delfield. Delfield neither assumes, nor authorizes any other person to assume for Delfield, any other liability in connection with Delfield's products.**

Removal or defacement of the original Serial Number or Model Number from any Unit shall be deemed to release Delfield from all obligations hereunder or any other obligations, express or implied.

Parts furnished by suppliers to Delfield are guaranteed by Delfield only to the extent of the original manufacturer's express warranty to Delfield. Failure of the Original Purchaser to receive such manufacturer's warranty shall in no way create any warranty, express or implied, or any other obligation or liability on Delfield's part in respect thereof.

If shipment of a replacement part is requested prior to the arrival in the Delfield factory of the part claimed to be defective, the Original Purchaser must accept delivery of the replacement part on a C.O.D. basis, with credit being issued after the part has been received and inspected at Delfield's plant and determined by Delfield to be within this Warranty.

Under no condition does this Warranty give the Original Purchaser the right to replace the defective Unit with a complete Unit of the same manufacturer or of another make. Unless authorized by Delfield in writing, this Warranty does not permit the replacement of any part, including the motor-compressor, to be made with the part of another make or manufacturer.

No claims can be made under this Warranty for spoilage of products for any reason, including system failure.

The installation contractor shall be responsible for building access, entrance and field conditions to insure sufficient clearance to allow any hood(s), vent(s) or Unit(s), if necessary, to be brought into the building. Delfield will not be responsible for structural changes or damages incurred during installation of the Unit or any exhaust system.

Delfield shall not be liable in any manner for any default or delay in performance hereunder caused by or resulting from any contingency beyond Delfield's control, including, but not limited to, war, governmental restrictions or restraints, strikes, lockouts, injunctions, fire, floods, acts of nature, short or reduced supply of raw materials, or discontinuance of the parts by the original part manufacturer.

**Except as provided in any Additional Four Year Protection Plan, if applicable, and the Service Labor Contract, if applicable, the foregoing is exclusive and in lieu of all other warranties, whether written or oral, express or implied. This Warranty supersedes and excludes any prior oral or written representations or warranties. Delfield expressly disclaims any implied warranties of merchantability, fitness for a particular purpose or compliance with any law, treaty, rule or regulation relating to the discharge of substances into the environment. The sole and exclusive remedies of any person relating to the Unit, and the full liability of Delfield for any breach of this warranty, will be as provided in this warranty.**

Other than this Delfield Standard One Year Limited Warranty, any applicable Delfield Additional Four Year Protection Plan or applicable Delfield Service Labor Contract, the Original Purchaser agrees and acknowledges that no other warranties are offered or provided in connection with or for the Unit or any part thereof.

**In no event will Delfield be liable for special, incidental or consequential damages, or for damages in the nature of penalties.**

- Applicable Law.** Variation of Terms. The rights and obligations of Seller and Buyer under an order shall be governed by the laws of the state where accepted by Seller. No waiver, modification, or addition to any of the terms of this order shall be binding on Seller unless made in writing by The Delfield Company. The provisions of an order are intended by Buyer and Seller as a final expression of their agreement and are intended also as a complete and exclusive statement of all terms applicable to Buyer's order.

**NOTE: Possession of this price list does not necessarily constitute an offer to sell by The Delfield Company.**

This Price Guide supersedes all other price lists. Although reasonable care has been taken to insure the accuracy of information in this Price Guide, Delfield cannot be held liable for any errors or omissions. Prices shown in this Price Guide are for standard Delfield models with standard electrical characteristics as described in sales and technical literature. All prices and specifications are subject to change without notice.

## Payment Terms

All shipments are F.O.B. point of manufacture. The terms of sale are subject to credit approval. These terms may be modified at any time prior to shipment. All shipments will be made on a *pro forma* invoice or C.O.D. basis unless otherwise approved.

If the total selling price is not paid when due, buyer shall pay late charges equal to the highest lawful contract rate of interest not to exceed 1 1/2% per month computed from the due date on the unpaid balance of the total selling price.

## Shipping Carrier

Delfield reserves the right to ship merchandise via any responsible carrier available at the time equipment is ready for shipment. When carrier or shipping routing is designated by dealer, Delfield will attempt to comply. Delfield cannot be held responsible for carrier rate differences; this is beyond our control. Rate differences are entirely between carrier and purchaser.

## Returned Goods

Permission must first be obtained from Delfield's home office before returning any merchandise. Returned merchandise is subject to a minimum 25% handling charge. All returned goods, cartons or crates must display our return authorization number. Any returned goods shipment lacking the return authorization number will be refused, with all additional freight costs to be borne by the returning party.

## Concealed Damages

All of our crating conforms to general motor carrier specifications. If the container shows rough handling or visible damage, in order to minimize liability, a full inspection is necessary upon arrival. A notation must be placed on the freight bill and signed by the truck driver. Appearance of damage will necessitate removing the crate in the presence of the driver. *Claims for damages must be filed at once by purchaser with the freight carrier.*

## Taxes

Prices shown do not include federal, state or other existing taxes. *Applicable taxes will be charged and added to the invoice unless an exemption certificate and tax identification number is received.*

## Storage Charges

Our shipping commitment is determined in accordance with delivery requirements and our best ability to fabricate. If, after the equipment has been fabricated, the customer requests delay in shipment and warehousing is required, the following schedule will apply: 1) Any equipment held for shipment at the purchaser's request for a period of 30 days beyond the delivery date specified shall become immediately payable. 2) If equipment is held beyond 60 days after the delivery date specified, storage charges will be added.

## Sanitation Codes

If you are placing equipment into an area which has certain sanitation requirements other than N.S.F. standards, Delfield must be advised of these specifications in detail before fabrication of the equipment, in order that we may quote additional costs, if any. Failure to notify Delfield before fabrication releases us from any obligation to modify our standards without additional charges.

## Orders and Drawings

To assure prompt and correct fabrication, Delfield must have all necessary information on the original order. Do not overlook finishes, accessories, and other options needed for a finished installation.

Please check the following items when ordering:

- Are all model numbers correct?
- Are stainless steel or laminate finished ends required?
- Is the laminate pattern and/or color number included?
- Are extra utility outlets needed?
- Are overshelves needed?
- Are end fillers and/or risers needed?
- Are you using natural, manufactured or bottled gas?
- Is a special refrigerant required?
- Are all specifications of equipment by others included?
- Are the electrical specifications correct?
- Are kick plates needed?
- Are special tops and backs needed for focal point operation?
- Is your shipping address complete, including zip code?
- Is special shipping required?
- Have you indicated the date required?

## Service Parts

All orders for service parts have a minimum charge. This policy may be modified by Delfield without notice. Prices shown for parts in this price list are for use when ordering an accessory with an original unit. Prices may vary when ordered separately from the Parts Department.

## Warranty

Warranty must be purchased at the time of sale only.

INDEX	DCCS-SD .....	68	KCS .....	104
200 .....	DCDM.....	69	KCSC-B.....	97
300 .....	DCFS.....	74	KCSC-EF.....	97
402 .....	DCFSR .....	75	KCTS.....	104
403 .....	DC-FT .....	63	KCU .....	101
406 .....	DC-H .....	61	KH .....	96
406-CA .....	DCHS .....	69	KHC-NU .....	98
407 .....	DC-IC .....	62	KHCR-B .....	98
407-CA .....	DC-L.....	63	KRB .....	104
4400N.....	DC-MC .....	62	LT .....	147
4400N-M .....	DCRU.....	64	MF/MFSC .....	148
4400N-S.....	DCRU-H .....	64	N .....	130
4500N.....	DCRU-IC .....	65	N6 .....	130
6000XL.....	DCRU-L.....	66	N10 .....	130
6000XL-R.....	DCRU-MC.....	65	N14 .....	130
6100XL.....	DCRU-T.....	67	N8000.....	139
6100XL-R.....	DC-T.....	67	N8000N.....	139
8100-EF.....	DC-TM.....	69	N8000-R.....	71, 144
18600BSTM.....	DIS .....	145	N8100B .....	139
18600BUCM.....	ECOS-E.....	52	N8100-BR.....	71, 144
18600PDL .....	ECSR24.....	52	N8100-FA .....	140
18600PTBM.....	EHEI-E.....	52	N8100N.....	139
18600PTL .....	EODC.....	53	N8200.....	141
18600VD.....	EODC36I.....	53	N8200G.....	141
ACR .....	EODC36S.....	53	N8600.....	142
ASM .....	ESIC36.....	53	N8700.....	143
CAB2.....	ESOS .....	53	N8700N.....	143
CAB3.....	ESSW36.....	53	N8700-R.....	71, 144
CAB4.....	F5 .....	57	N8800.....	142
CD .....	F15 .....	58	ND .....	146
CPS .....	F18RC119-ES1.....	27	NDF .....	130
CT .....	F26/F27.....	49	NLFAC.....	131
CTP-NB .....	F28/F29.....	49	NSCF.....	133
D4400N.....	F2900VD.....	25	PWT .....	104
D4400N-M.....	FLEXISHIELD® FOOD SHIELDS ....	74	SALD-1.....	157
D4400N-S.....	FT2-SN .....	157	SB .....	146
D4500N.....	KC .....	102	SC .....	93
DCBC .....	KCF .....	103	SCF .....	94, 133
DCBU.....	KCFM .....	103, 132	SCFM .....	94, 132
DCBU.....	KCFT-NU.....	99	SCFT-NU.....	90
DCCS-DD .....	KCI .....	100	SCI .....	91
	KCM .....	103, 132	SCM .....	94, 132

SCN .....	135	SSRN/SARN/SMRN .....	13
SCS .....	95	SSRPT/SARPT/SMRPT .....	17
SCSC-B.....	88	SSRPTS/SARPTS/SMRPTS.....	17
SCSC-EF.....	88	SSRRI/SARRI/SMRRI .....	19
SCTRI.....	95	SSRRT/SARRT/SMRRT .....	20
SCTS.....	95	SSR/SAR/SMR.....	13
SCU .....	92	SSRS/SARS/SMRS .....	13
SE .....	82	ST4048 .....	36
SE-CS.....	81	ST4148 .....	36
SE-C/SES-C .....	78	ST4400N.....	37
SE-F/SES-F .....	80	ST4400N-M .....	42
SE-HC/SES-HC.....	79	ST4400N-S.....	41
SE-H/SES-H .....	78	ST4500N .....	37
SE-ICE.....	82	STD4400N.....	37
SE-I/SES-I .....	79	STD4400N-M .....	42
SE-TS.....	81	STD4400N-S.....	41
SE-U/SES-U.....	80	STD4500N.....	37
SH .....	87	SWT .....	95
SHC .....	89	T .....	155
SHCR-B.....	89	T2 .....	155
SLT4 .....	135	T5 .....	29
SPCS.....	124	T14D .....	29
SPF .....	119	T24C.....	29
SPH .....	115	T40 .....	29
SPHM.....	122	TT .....	156
SPM .....	123	TT2 .....	156
SPR .....	116	UC4048.....	32
SPRDP .....	120, 121	UC4148.....	32
SPRF.....	118	UC4400.....	33
SPRH.....	117	UC4400N-M .....	44
SRB .....	95	UC4400N-S.....	43
SSD/SAD/SMD.....	14	UC4500 .....	33
SSFN/SAFN/SMFN.....	16	UCD4400N-M.....	44
SSFPT/SAFPT/SMFPT .....	17	UCD4400N-S .....	43
SSFRI/SAFRI/SMFRI.....	19	UCE .....	158
SSF/SAF/SMF.....	16	UTS .....	158
SSFS/SAFS/SMFS .....	16	UTSP .....	158
SSHPT/SAHPT/SMHPT.....	15		
SSHRI/SAHRI/SMHRI .....	19		
SSHRT/SAHRT/SMHRT .....	20		
SSH/SAH/SMH.....	15		
SSRFF.....	18		

# DELFIELD REP GROUPS

**Bowerman Associates, Inc.**  
Territory: Upstate New York  
(315) 453-5288  
www.ebowerman.com

**Duskie, Utsey & Associates**  
Territory: North Carolina, South Carolina  
(704) 663-0036

**E-Source**  
Territory: Texas and Oklahoma (except for the El Paso area)  
(214) 614-0215  
www.esourceequipment.com

**Food Equipment Reps**  
Territory: Florida  
(800) 226-8389  
www.ferinc.net

**Garland Canada**  
Territory: Canada and International  
(888) 442-7526

**The Hansen Group**  
Territory: Georgia  
(770) 667-1544  
www.thehansengroup.net

**Hatch-Jennings, Inc.**  
Territory: Connecticut, Maine, Massachusetts,  
New Hampshire, Vermont and Rhode Island  
(800) 225-5090  
kristenf@hatch-jennings.com

**Kain-McArthur, Inc.**  
Territory: S. Illinois, Iowa, Nebraska, Missouri, Kansas  
(913) 829-3700  
www.kainmcarthur.com

**Lane Marketing Group**  
Territory: Maryland, Washington DC and Virginia  
(301) 858-5058  
www.lanegroup.com

**MarketSmart**  
Territory: Northern California, Northern Nevada  
(925) 846-6237  
www.marketsmartinc.com

**Merkolat**  
Territory: Central America, South America,  
Mexico and Caribbean  
(561) 792-6341

**Mirkovich & Associates, Inc.**  
Territory: Illinois and Wisconsin  
(630) 792-0080  
www.mirkovich.com

**Moccia Enterprises, Inc.**  
Territory: Delaware, Southern New Jersey and Eastern  
Pennsylvania  
(856) 829-5562  
www.mocciaent.com

**Performance Food Equipment Group**  
Territory: Connecticut, Metropolitan New York,  
Long Island and New Jersey  
(201) 797-2266  
Email: info@performreps.com

**Performance Reps NW**  
Territory: Washington, Montana, Northern Idaho and  
Boise, Alaska, Oregon and Hawaii  
(800) 462-0006  
www.prnw.com

**Preferred Marketing Group**  
Territory: Southern California and Southern Nevada  
(818) 994-9292  
www.pmgnow.com

**Redstone**  
Territory: Colorado, Wyoming, Utah and Idaho  
(303) 922-6920

**RepsSouth, Inc.**  
Territory: Mid and East Tennessee, Alabama and Florida  
Panhandle  
(615) 370-1311  
www.repsouth.com

**Vader & Landgraf**  
Territory: Minnesota, North Dakota, South Dakota and  
Western Wisconsin  
(612) 331-1251  
www.vaderandlandgraf.com

**The Wallin Group**  
Territory: Louisiana, Mississippi, Arkansas and Western  
Tennessee  
(504) 733-3344  
www.wallingroup.com

**Zink Marketing**  
Territory: Indiana, Michigan, Ohio, West Virginia, Kentucky,  
Western Pennsylvania  
(614) 899-9500



980 S. Isabella Road • Mt. Pleasant, MI 48858  
1.800.733.8948 or +1 989-773-7981 • Fax: 1.800.669.0619 • www.delfield.com  
All prices and specifications are subject to change without notice.  
DPCAUG11 07/11

